



**Leaderway** VERTICAL MACHINING CENTER

# VERTICAL MACHINING CENTER

## PARTS LIST

### VMC-2516

LEADERWAY CNC TECHNOLOGIES CO., LTD.  
NO. 36, Ln. 211, Taiming Rd.,  
Wuri Dist, TAICHUNG 41468, TAIWAN  
TEL: +886-4-2335-0711  
FAX: +886-4-2335-0986



# 1. VMC-2516R

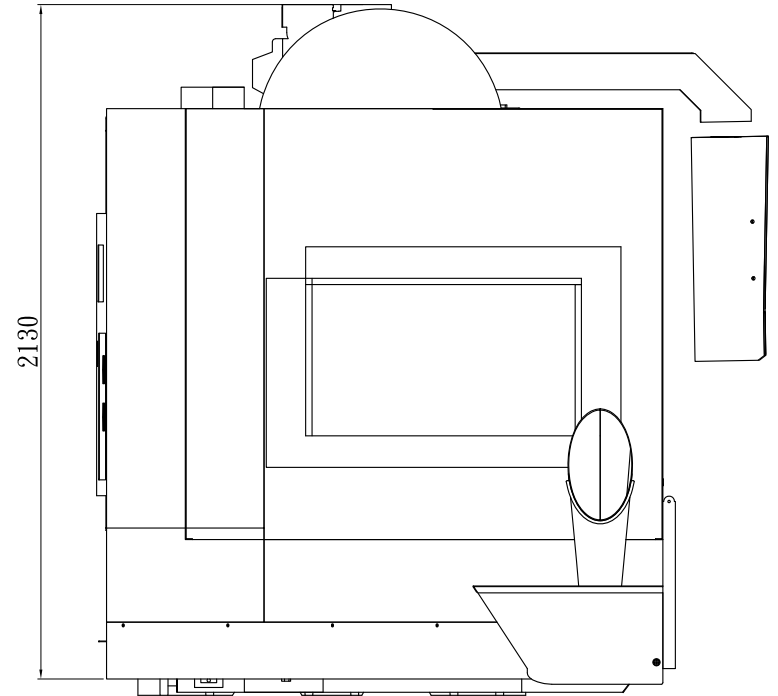
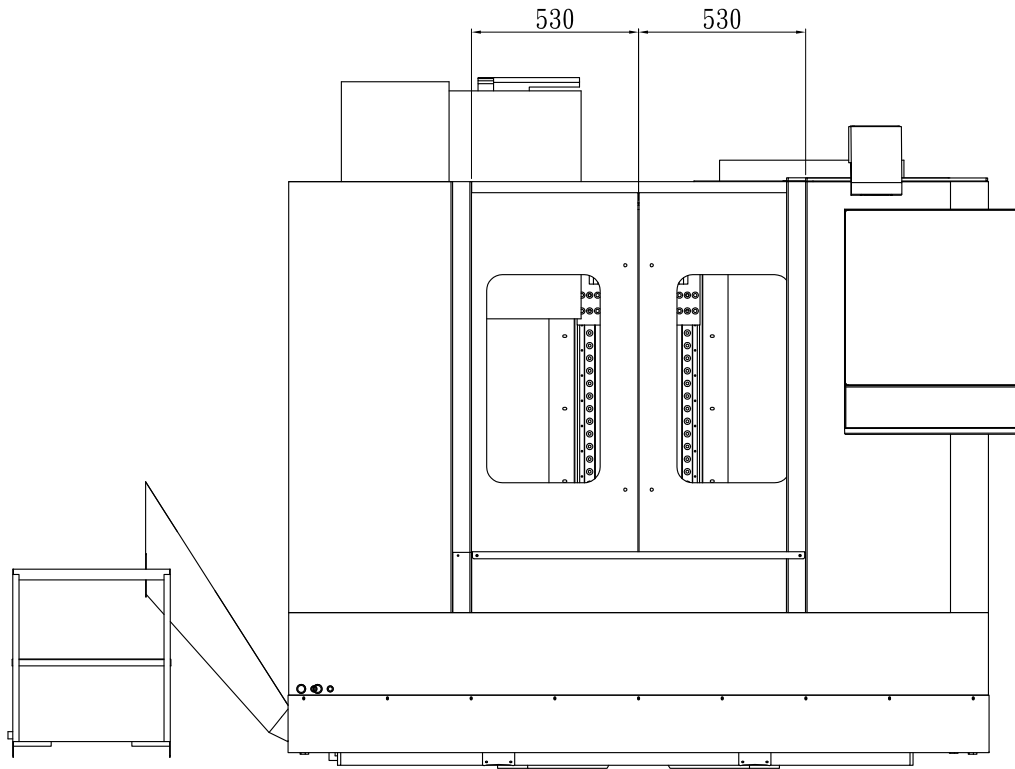

# Leaderway Machinery Co. Ltd.

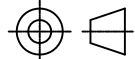
Scale 1:1	Drawing Name VMC-2516 外罩圖			Page 2/2	A4
	Drawn	Name AMY	Date 97.12.04	Draw No. -----	
	Control	----	----		

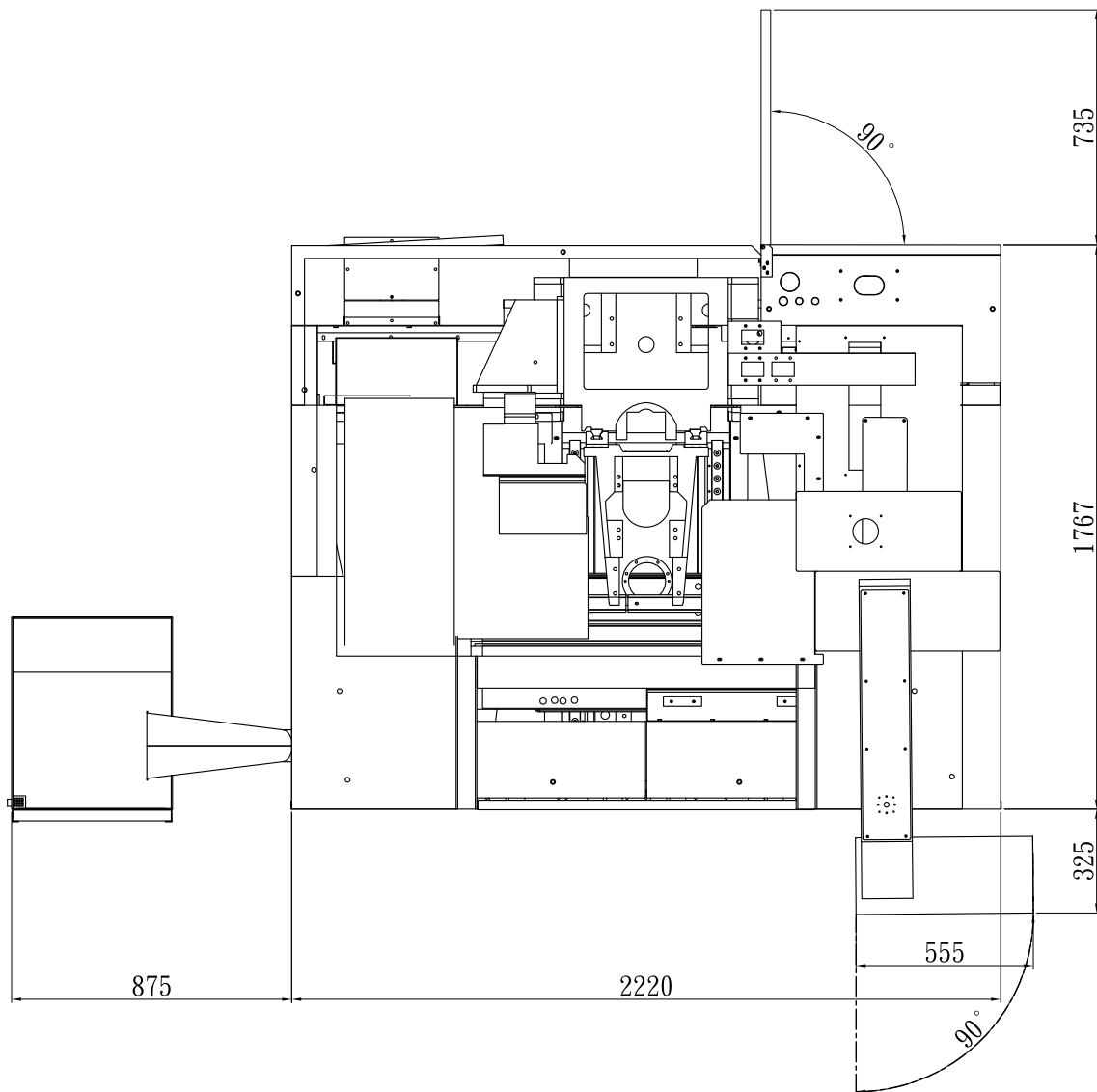

# Leaderway Machinery Co. Ltd.

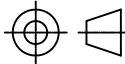
Scale 1:1	Drawing Name VMC-2516 外罩圖			Page 1/2	A4
	Drawn	Name AMY	Date 97.12.04	Draw No. -----	
	Control	----	----		

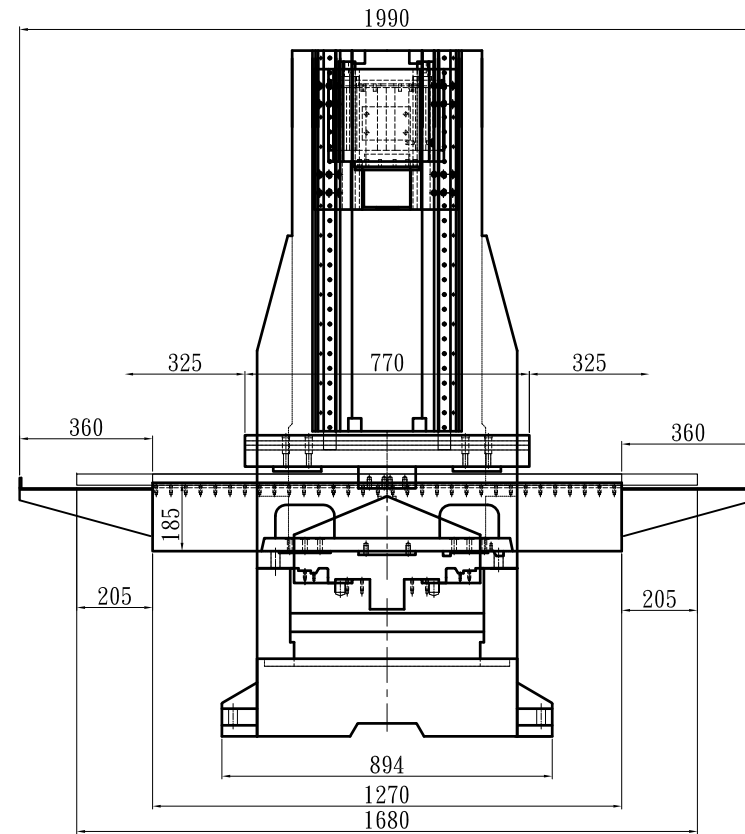
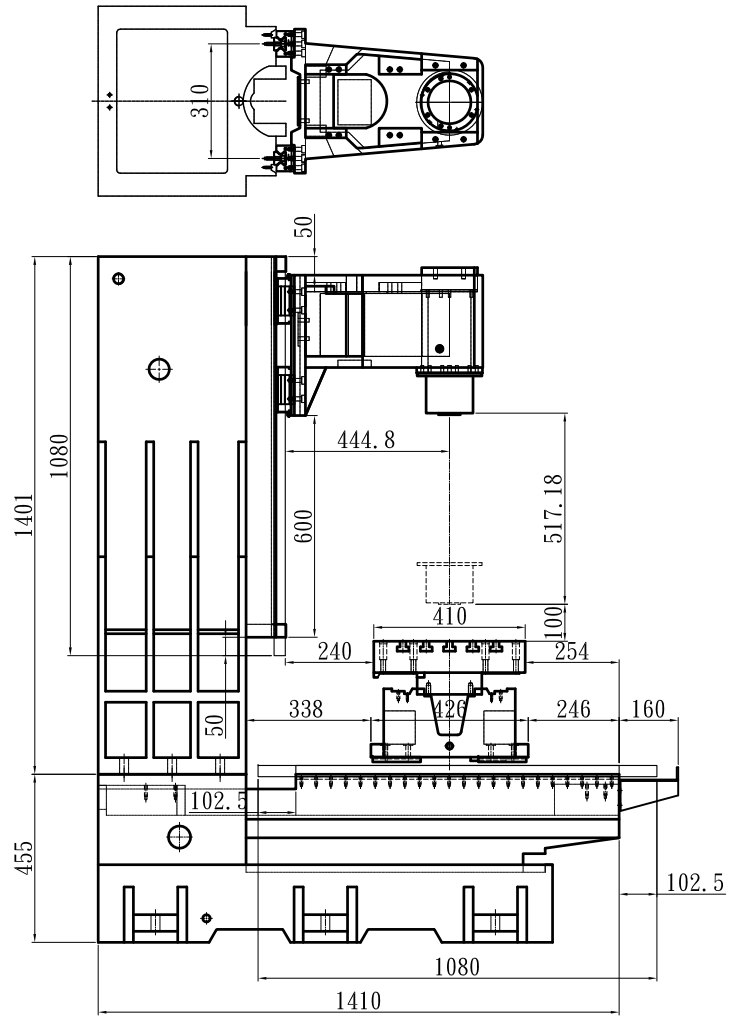

# Leaderway Machinery Co. Ltd.

Scale 1:1	Drawing Name VMC-2516		Page 1/1	A4
	Drawn Name AMY	Date 97.12.04	Draw No. -----	
	Control ----	----		

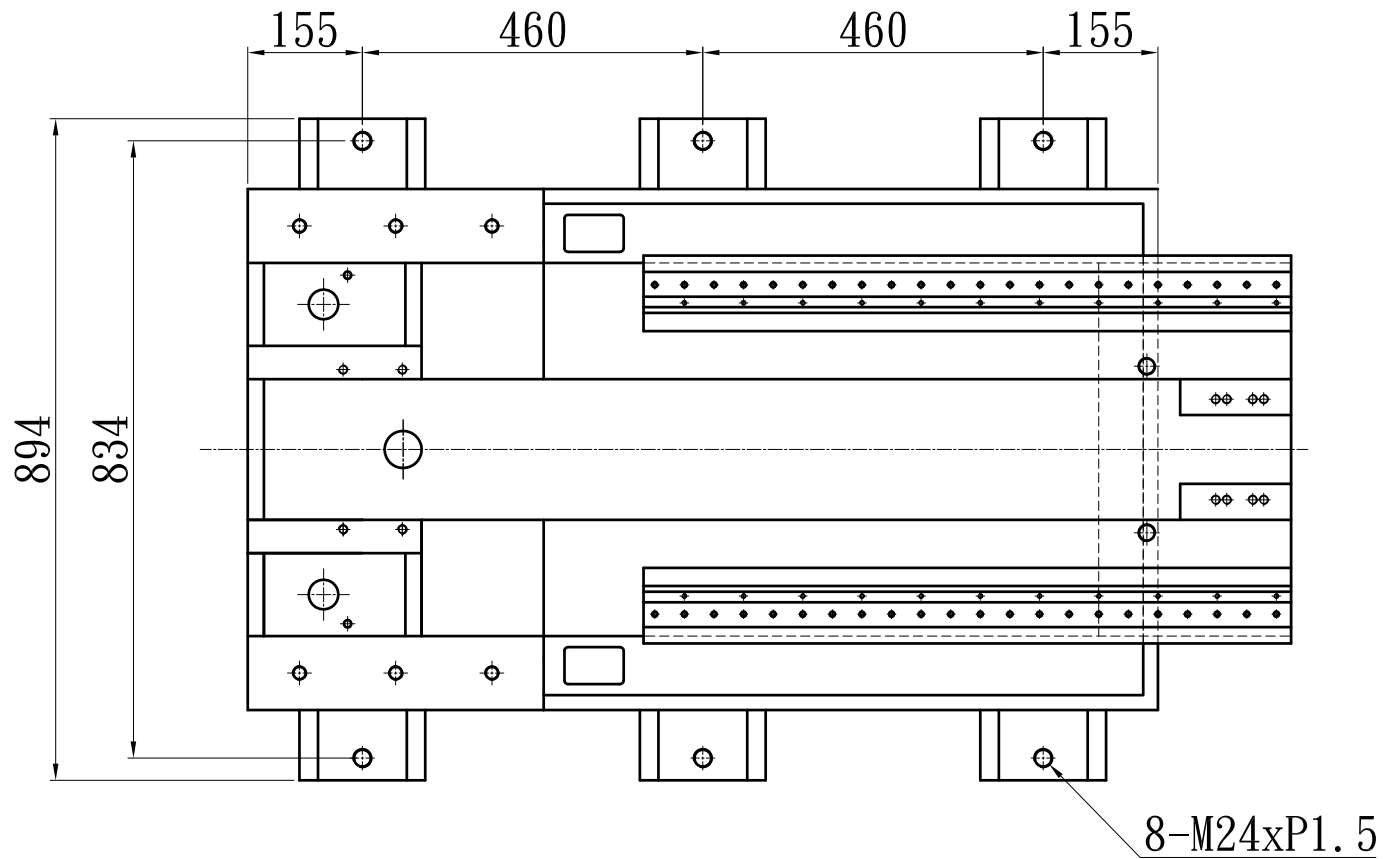

Leaderway Machinery Co. Ltd.

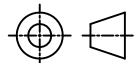
Scale 1:1	Drawing Name VMC-2516 地基圖			Page 1/1	A4
	Drawn	Name AMY	Date 97.12.04	Draw No. -----	
	Control	----	----		

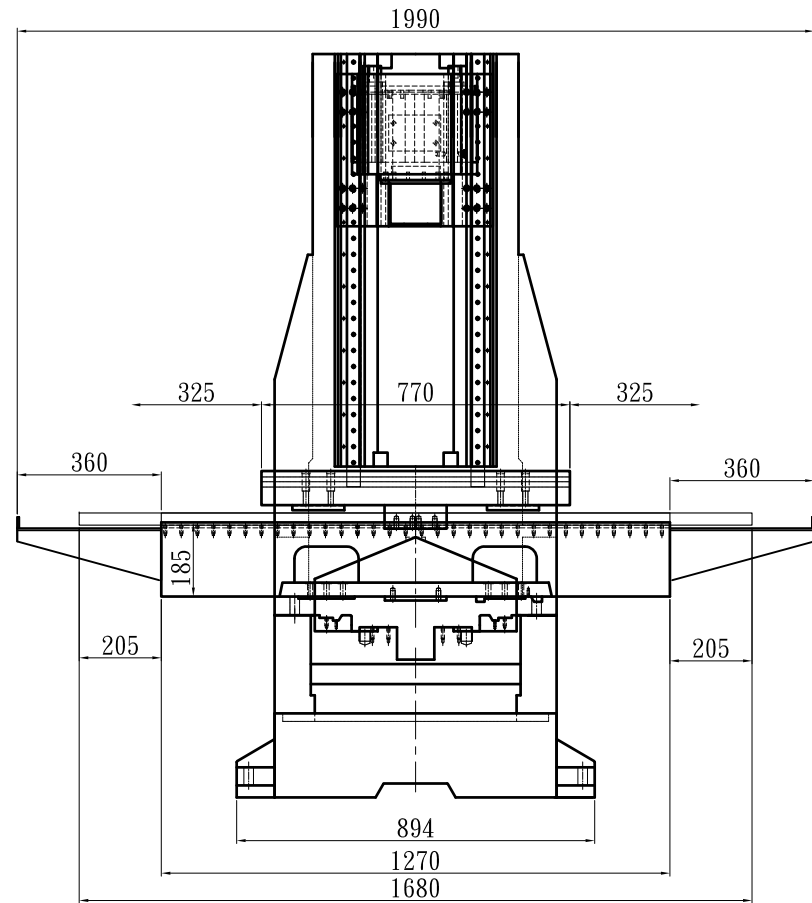
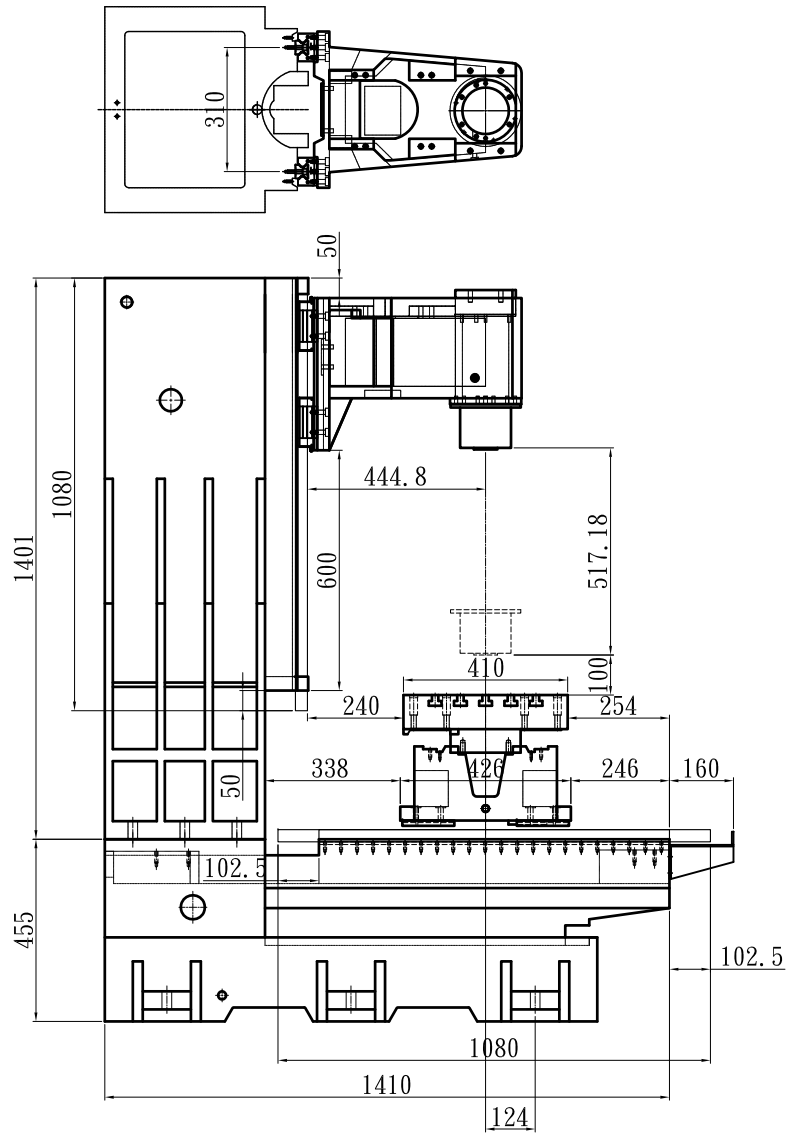

<b>Leaderway Machinery Co. Ltd.</b>					
Scale <b>1:1</b>	Drawing Name <b>VMC-2516 地基圖</b>				Page <b>1/1</b>
	Drawn Name <b>AMY</b>	Date <b>97.12.04</b>	Draw No. -----		
	Control -----	-----	-----		

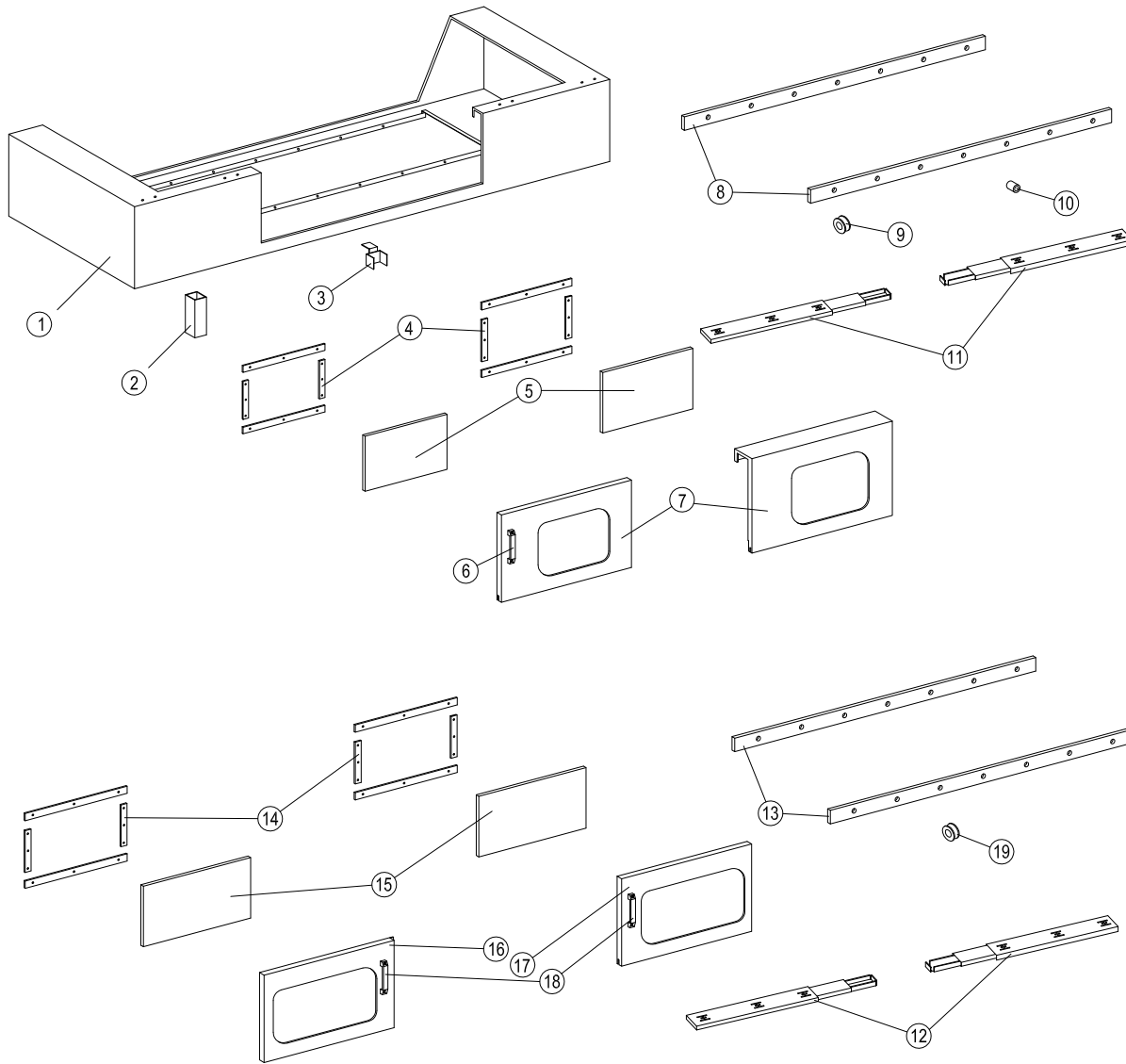

ITEM	DESCRIPTION	Q'TY
①	工作台護罩	1
②	套 管	1
③	固定門座	1
④	壓 條	8
⑤	壓 克 力	7
⑥	弓 形 手 把	1
⑦	活 動 門	2
⑧	軌 道	2
⑨	滑 輪	4
⑩	套 筒	10
⑪	三 節 滑 軌	2
⑫	三 節 滑 軌	2
⑬	軌 道	2
⑭	壓 條	8
⑮	壓 克 力	2
⑯	左 側 活 動 門	1
⑰	右 側 活 動 門	1
⑱	弓 形 手 把	2
⑲	滑 輪	4
⑳		
㉑		
㉒		
㉓		
㉔		

# Leaderway Machinery Co. Ltd.

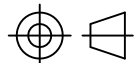
Scale 1:1	Drawing Name VMC-2516 單開，雙開 工作台護罩板金圖			Page 1/1	A4
	Drawn Control	Name AMY	Date 97. 12. 04	Draw No. -----	



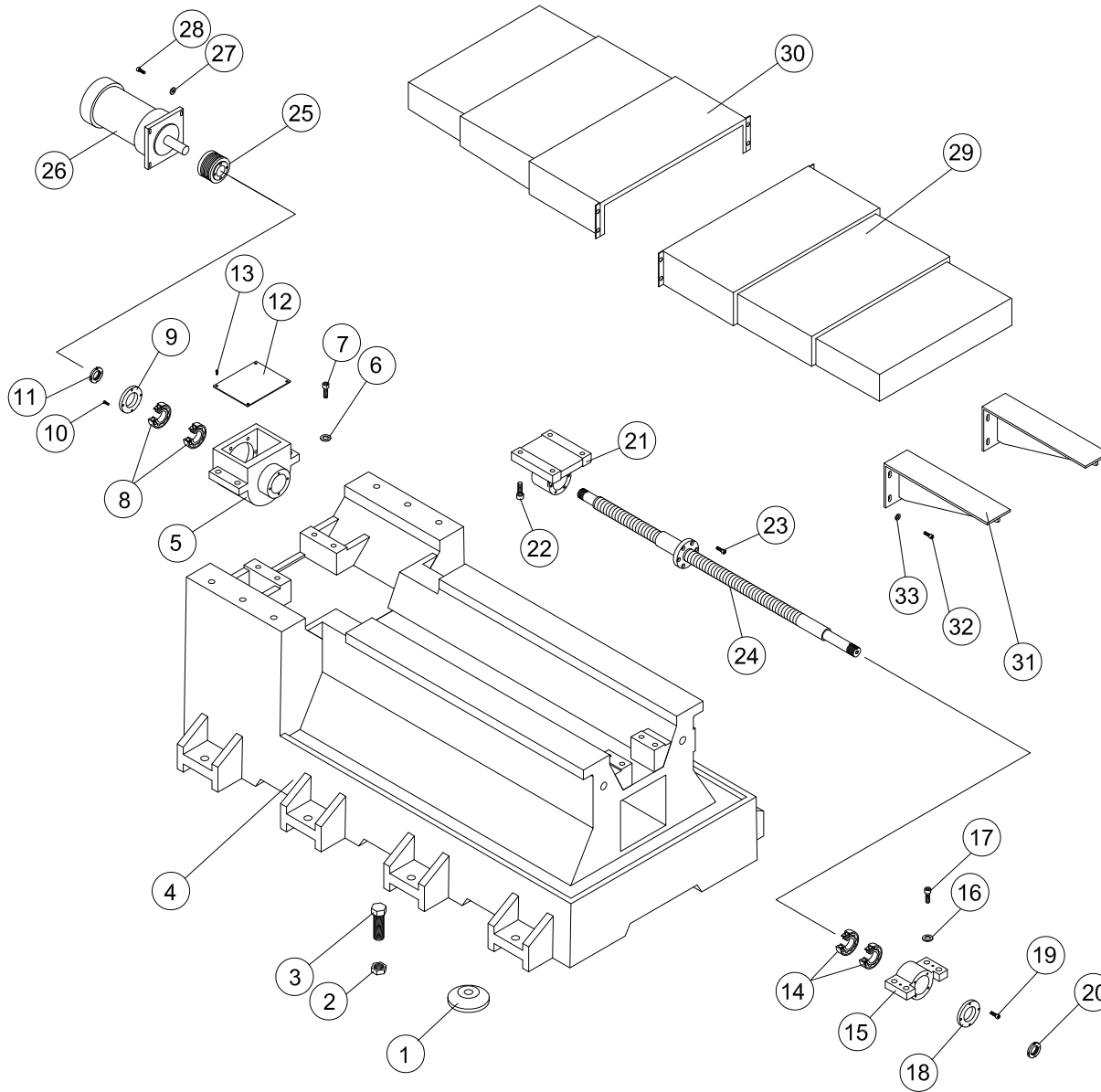

ITEM	DESCRIPTION	Q'TY	ITEM	DESCRIPTION	Q'TY
①	Leveling Pad	8	②⑤	Coupling	1
②	Nut	8	②⑥	Motor	1
③	Screw (M24*P1.5)	8	②⑦	Washer	4
④	Base	1	②⑧	Screw	4
⑤	Bearing Bracket	1	②⑨	Front Way Cover	1
⑥	Washer	4	③⑩	Rear Way Cover	1
⑦	Screw (M4)	4	③⑪	Cover Brace	2
⑧	Bearing (25T AC62)	2	③⑫	Washer	6
⑨	Bearing Cover	1	③⑬	Screw (M6)	6
⑩	Screw (M6*20)	4	③⑭		
⑪	Nut	1	③⑮		
⑫	Cover	1	③⑯		
⑬	Screw	4	③⑰		
⑭	Bearing (25T AC62)	2	③⑱		
⑮	Bearing Bracket	1	③⑲		
⑯	Washer	4	④⑰		
⑰	Screw (M12)	4	④⑱		
⑱	Bearing Cover	1	④⑲		
⑲	Screw (M6*20)	4	④⑳		
⑳	Nut	1	④㉑		
㉑	Nut Bracket	1	④㉑		
㉒	Screw (M12)	4	④㉒		
㉓	Screw (M10)	4	④㉓		
㉔	Ballscrew	1	④㉔		

# Leaderway Machinery Co. Ltd.

Scale 1:1	Drawing Name VMC-2516 BASE			Page 1/1	A4
	Drawn	Name AMY	Date 97. 12. 04	Draw No. -----	
	Control	----	----		

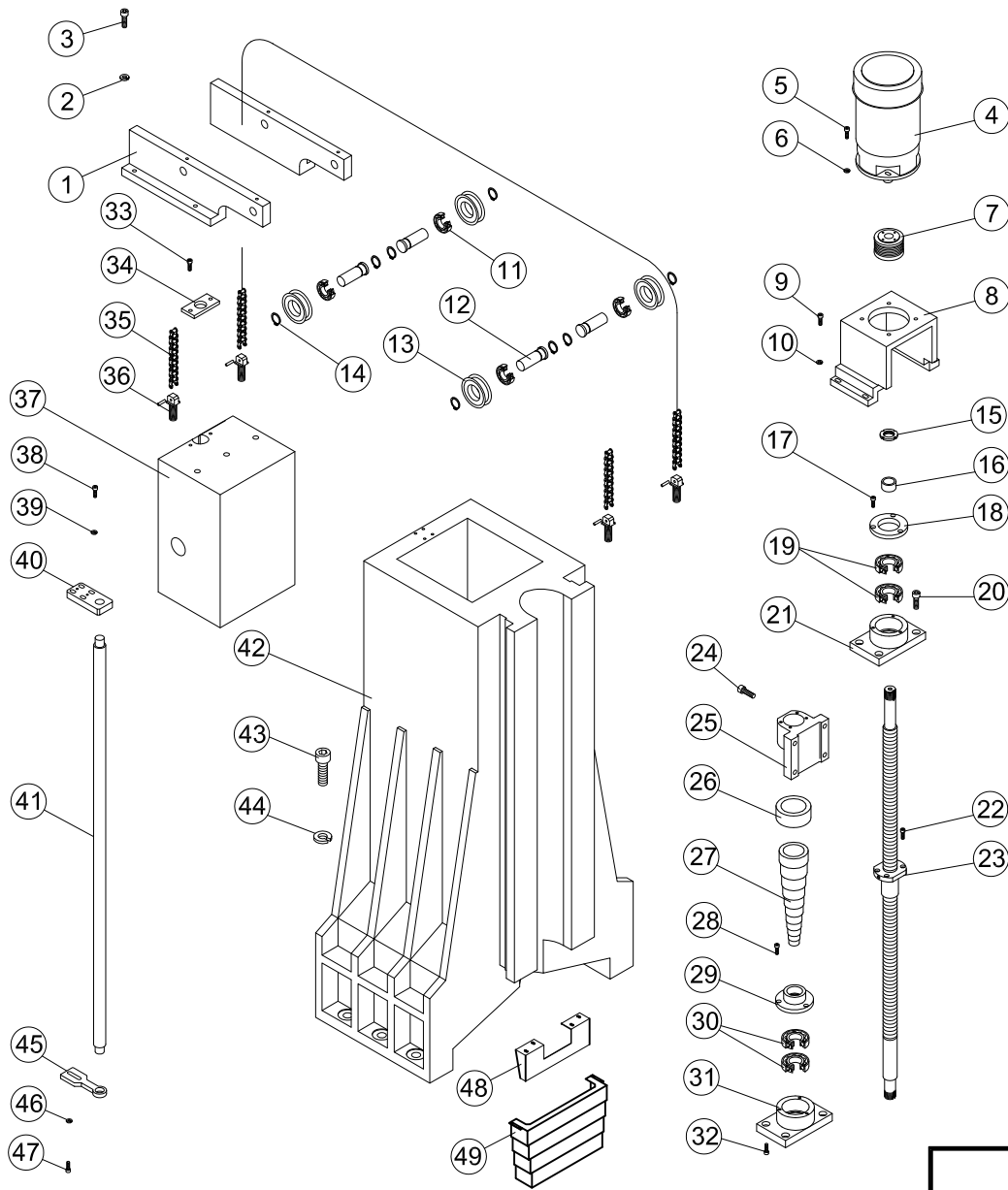

ITEM	DESCRIPTION	Q'TY	ITEM	DESCRIPTION	Q'TY	ITEM	DESCRIPTION	Q'TY
1	Chain Supporter	2	25	Nut Bracket	1	49	Cover	1
2	Washer	4	26	Upper Stay	1	50		
3	Screw (M5)	4	27	Ballscrew Chip Cover	1	51		
4	Motor	1	28	Screw (M6)	3	52		
5	Screw	4	29	Lower stay	1	53		
6	Washer	4	30	Bearing (#6025)	2	54		
7	Coupling	1	31	Bearing Bracket	1	55		
8	Motor seat	1	32	Screw (M10*35)	4	56		
9	Screw (M5)	4	33	Screw (M8)	4	57		
10	Washer	4	34	Buffer pad	1	58		
11	Bearing (#6205)	4	35	Chain	2	59		
12	Shaft	4	36	Screw (M16)	2	60		
13	Wheel	4	37	Count Balance	1			
14	C-Ring	8	38	Screw (M8)	4			
15	Nut	1	39	Washer	4			
16	Spacer	1	40	Guide pad	1			
17	Screw (M6*20)	3	41	Guide shaft	1			
18	Bearing Cover	1	42	Frame	1			
19	Bearing (#7025)	2	43	Screw (M24)	6			
20	Screw (M10*35)	4	44	Washer	6			
21	Bearing Bracket	1	45	Guide pad	1			
22	Screw (M10*25)	4	46	Washer	2			
23	Ballscrew	1	47	Screw (M8)	2			
24	Screw (M12*40)	4	48	Cover brace	1			

# Leaderway Machinery Co. Ltd.

Scale 1:1	Drawing Name VMC-2516 FRAME			Page 1/1	A4
	Drawn	Name AMY	Date 97.12.04	Draw No. -----	
	Control	----	----		

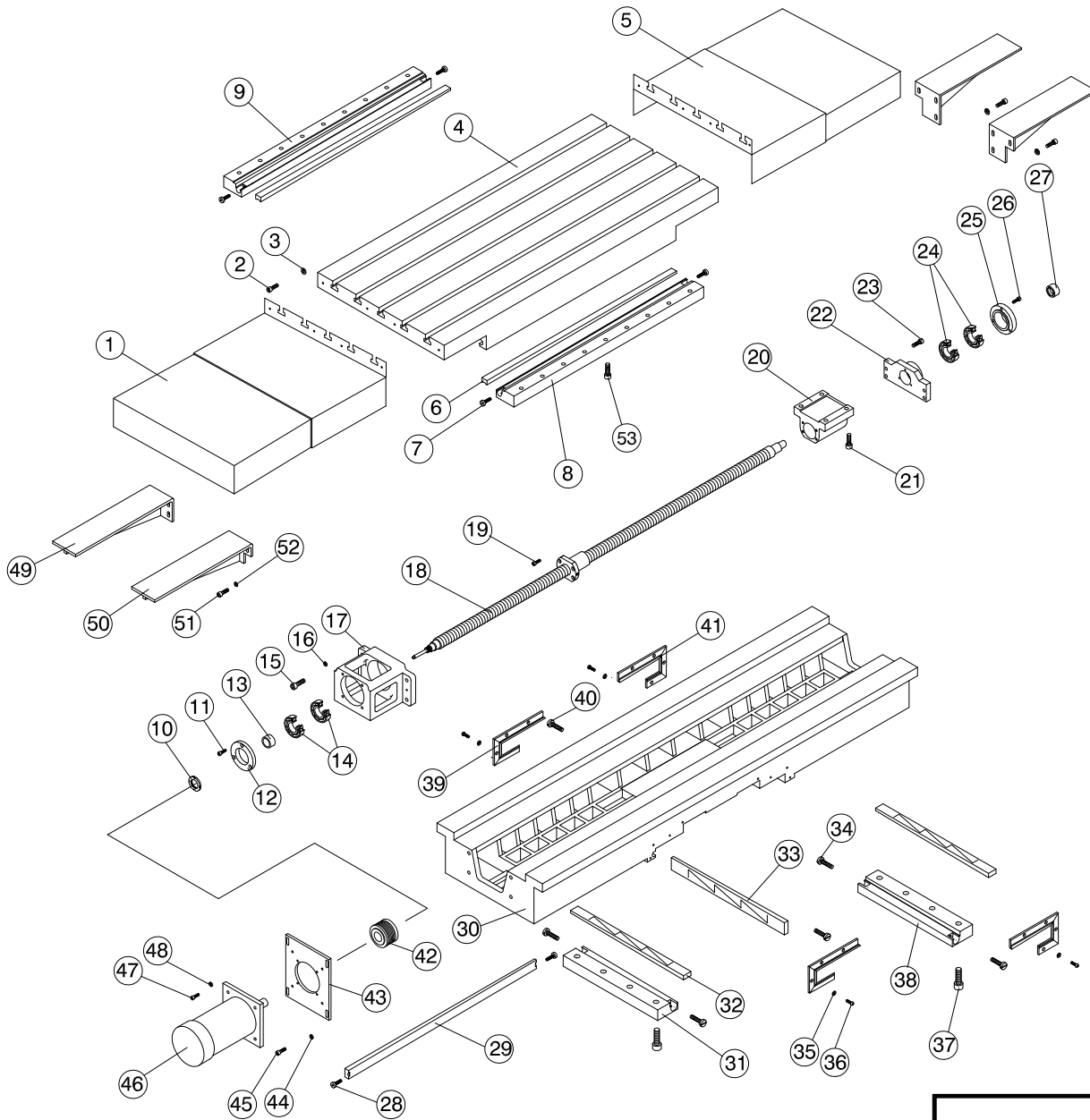

ITEM	DESCRIPTION	Q'TY	ITEM	DESCRIPTION	Q'TY	ITEM	DESCRIPTION	Q'TY
①	Left Way Cover	1	②⑤	Bearing Cover	1	④⑨	Cover brace	2
②	Screw (M6)	8	②⑥	Screw (M6*20)	3	⑤⑩	Cover brace	2
③	Washer	8	②⑦	Nut	1	⑤①	Screw (M6)	12
④	Table	1	②⑧	Gib Screw (5/16"*24NF)	2	⑤②	Washer	12
⑤	Right Way Cover	1	②⑨	Gib	1	⑤③	Screw (M12*40)	18
⑥	Gib	2	③⑩	Saddle	1	⑤④		
⑦	Gib Screw (5/16"*24NF)	4	③①	Bracket	1	⑤⑤		
⑧	Bracket	1	③②	Gib	2	⑤⑥		
⑨	Bracket	1	③③	Gib	1	⑤⑦		
⑩	Nut	1	③④	Gib Screw (5/16"*24NF)	2	⑤⑧		
⑪	Screw (M6*20)	3	③⑤	Washer	12	⑤⑨		
⑫	Bearing Cover	1	③⑥	Screw (M5)	12	⑥⑩		
⑬	Spacer	1	③⑦	Screw (M12*40)	8			
⑭	Bearing (25T AC62)	2	③⑧	Bracket	1			
⑮	Screw (M10*30)	4	③⑨	Wiper	2			
⑯	Washer	4	④⑩	Gib Screw (5/16"*24NF)	2			
⑰	Bearing Bracket	1	④①	Wiper	2			
⑱	Ball screw	1	④②	Coupling	1			
⑲	Screw (M10)	5	④③	Motor Plate	1			
⑳	Nut Bracket	1	④④	Washer	4			
㉑	Screw (M12)	4	④⑤	Screw (M8)	4			
㉒	Bearing Bracket	1	④⑥	Motor	1			
㉓	Screw (M8*30)	4	④⑦	Screw	4			
㉔	Bearing (#6205)	2	④⑧	Washer	4			

# Leaderway Machinery Co. Ltd.

Scale

1:1

Drawing Name

VMC-2516 TABLE

Page

1/1

A4

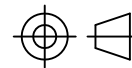

Drawn

Name

AMY

Date

97. 12. 04

Draw No.

Control

----

----

----

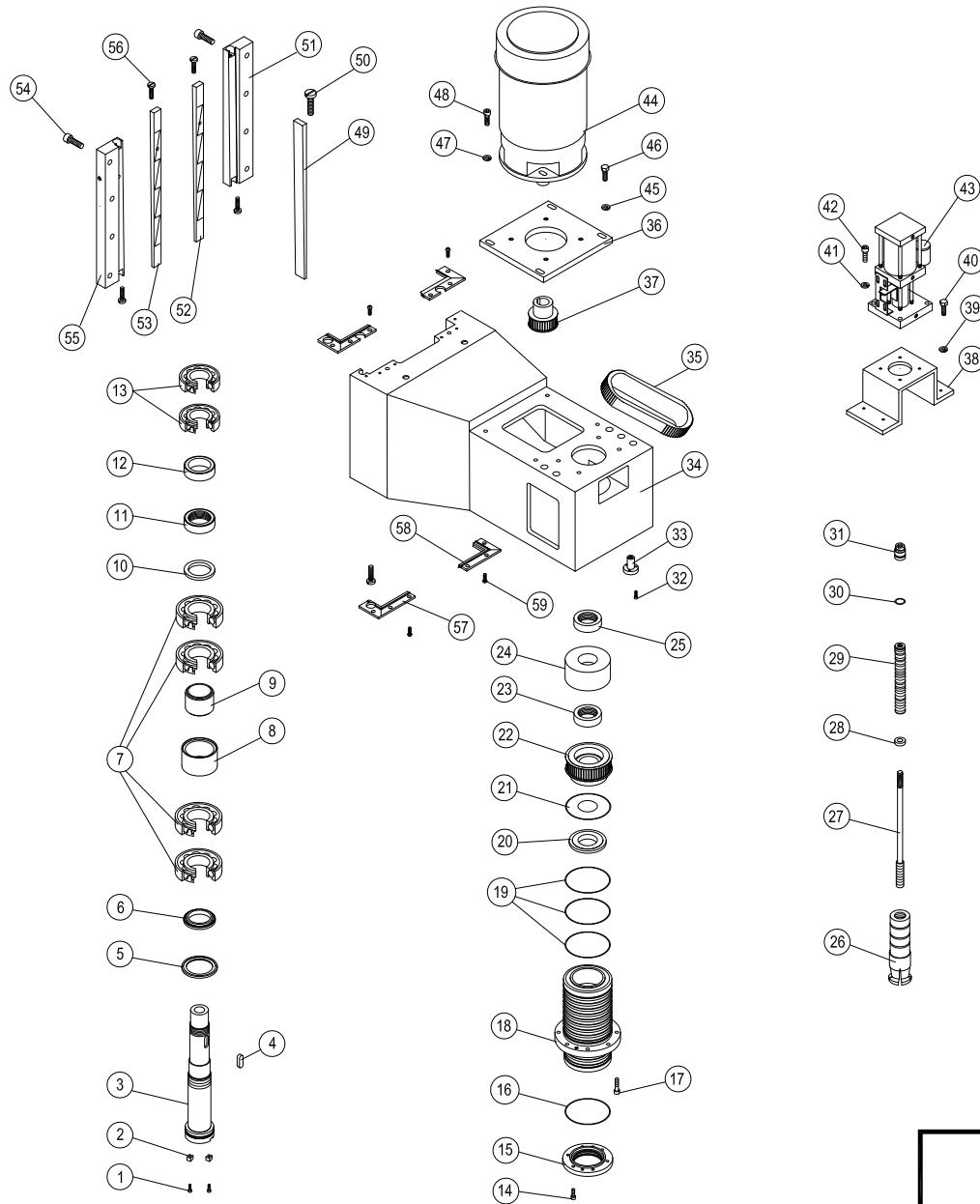

ITEM	DESCRIPTION	Q'TY	ITEM	DESCRIPTION	Q'TY	ITEM	DESCRIPTION	Q'TY
①	Screw (M6*16)	2	②⑤	Nut	1	④⑨	Gib	1
②	Key (16*16mm)	2	②⑥	4 Jaws	1	⑤⑩	Gib screw (5 /16"*24NF)	2
③	Spindle	1	②⑦	Draw Bar	1	⑤①	Bracket	1
④	Key	1	②⑧	Collar	1	⑤②	Gib	1
⑤	Seal (110*80mm)	1	②⑨	Disc Spring	1	⑤③	Gib	1
⑥	Seal (100*70)	1	③⑩	Collar	1	⑤④	Screw (M12*40)	10
⑦	Bearing (#7014)	4	③①	Nut	1	⑤⑤	Bracket	1
⑧	Spacer	1	③②	Screw (M6*16)	3	⑤⑥	Gib screw (5 /16"*24NF)	4
⑨	Spacer	1	③③	Coolant Nozzle	3	⑤⑦	Wiper	2
⑩	Nut	1	③④	Headstock	1	⑤⑧	Wiper	2
⑪	Collar	1	③⑤	Belt	1	⑤⑨	Screw (M5*10)	12
⑫	Collar	1	③⑥	Motor Plate	1	⑥⑩		
⑬	Bearing (#7013)	2	③⑦	Motor Piley (8YU-40T)	1			
⑭	Screw (M8*20)	8	③⑧	Cylinder seat	1			
⑮	Cover	1	③⑨	Washer	4			
⑯	O type ring (AS042)	1	④⑩	Screw (M8*30)	4			
⑰	Screw (M10*25)	8	④①	Washer	4			
⑱	Quill	1	④②	Screw (M8*30)	4			
⑲	O type ring (G140)	3	④③	Power Draw Bar	1			
⑳	Chip Cover	1	④④	Motor	1			
㉑	Chip Cover	1	④⑤	Washer	4			
㉒	Pulley (8YU40T)	1	④⑥	Screw (M12*20)	4			
㉓	Nut	1	④⑦	Washer	4			
㉔	Cover	1	④⑧	Screw	4			

# Leaderway Machinery Co. Ltd.

Scale 1:1	Drawing Name VMC-2516 HEADSTOCK			Page 1/1	A4
	Drawn	Name AMY	Date 97. 12. 04	Draw No. -----	
	Control	----	----		

## 2. VMC-2516RZ

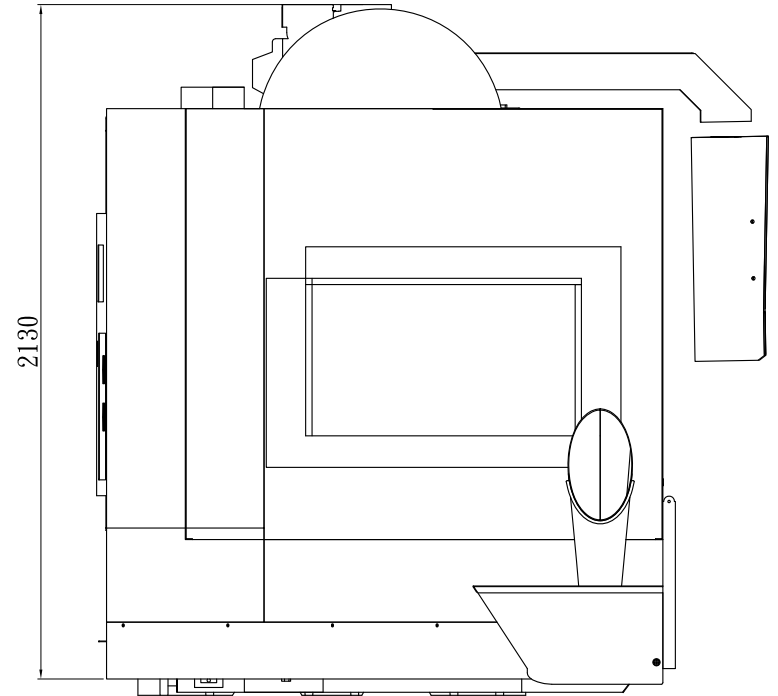
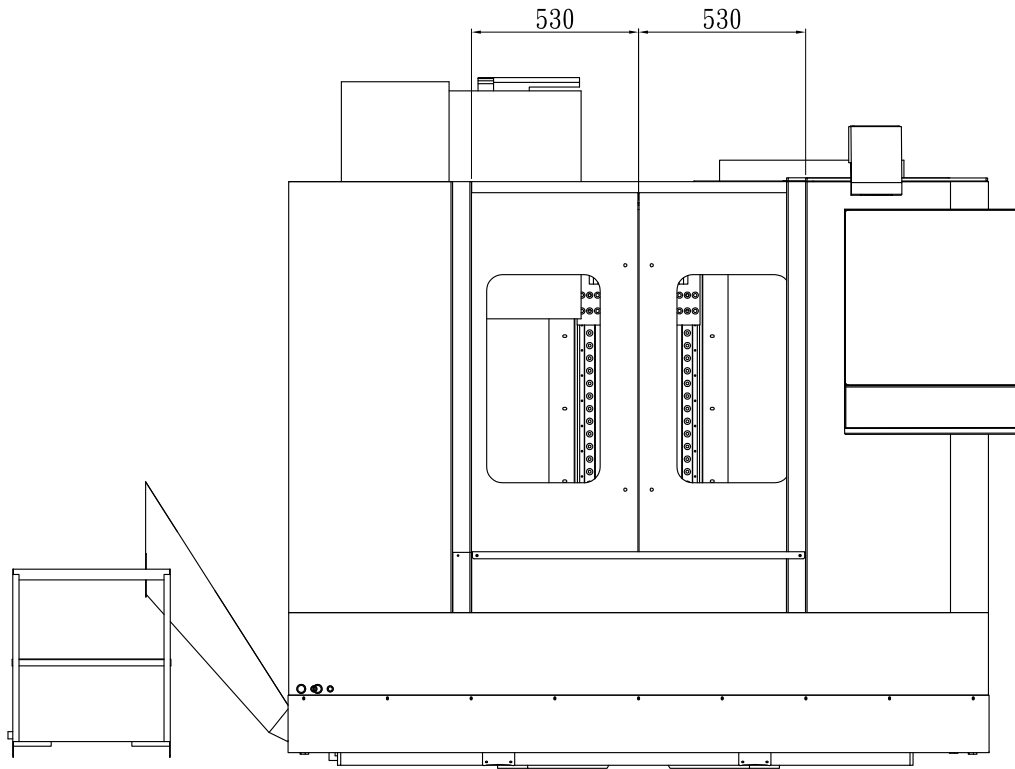

# Leaderway Machinery Co. Ltd.

Scale 1:1	Drawing Name VMC-2516 外罩圖			Page 2/2	A4
	Drawn	Name AMY	Date 97.12.04	Draw No. -----	
	Control	----	----		

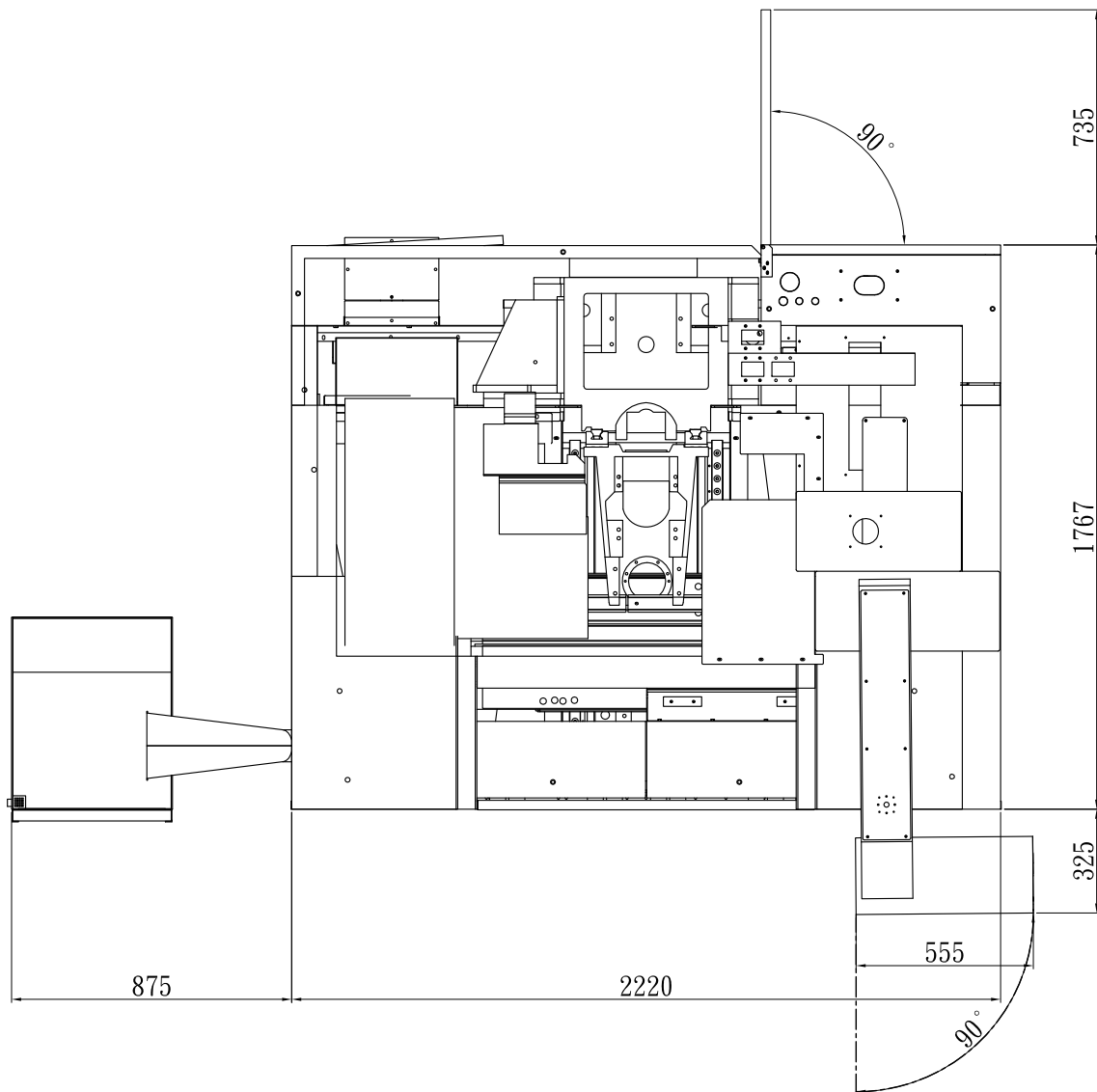

# Leaderway Machinery Co. Ltd.

Scale 1:1	Drawing Name VMC-2516 外罩圖			Page 1/2	A4
	Drawn	Name AMY	Date 97.12.04	Draw No. -----	
	Control	----	----		

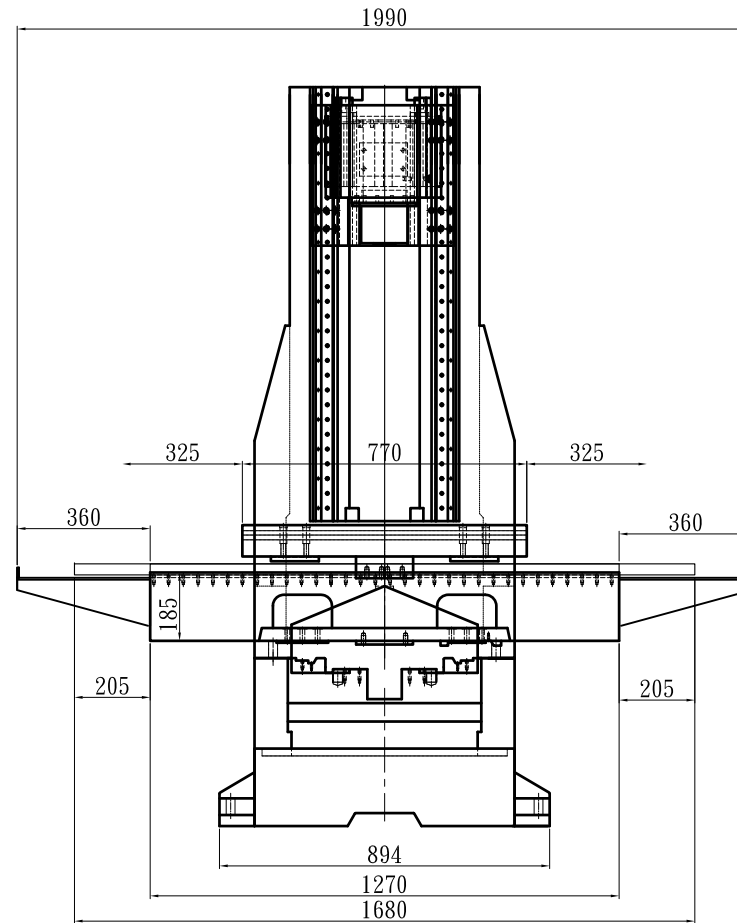
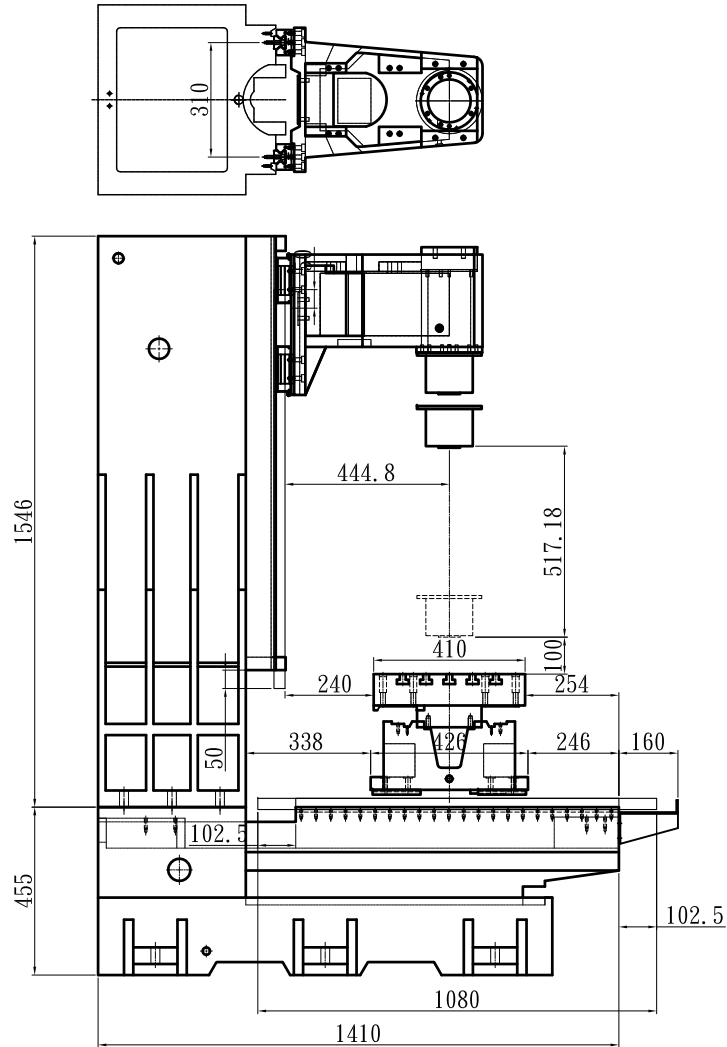

<h1>Leaderway Machinery Co. Ltd.</h1>				
Scale	Drawing Name			Page
1:1	VMC-2516(立柱加高)			1/1
	Drawn	Name	Date	Draw No.
	Control	AMY	97.12.04	----



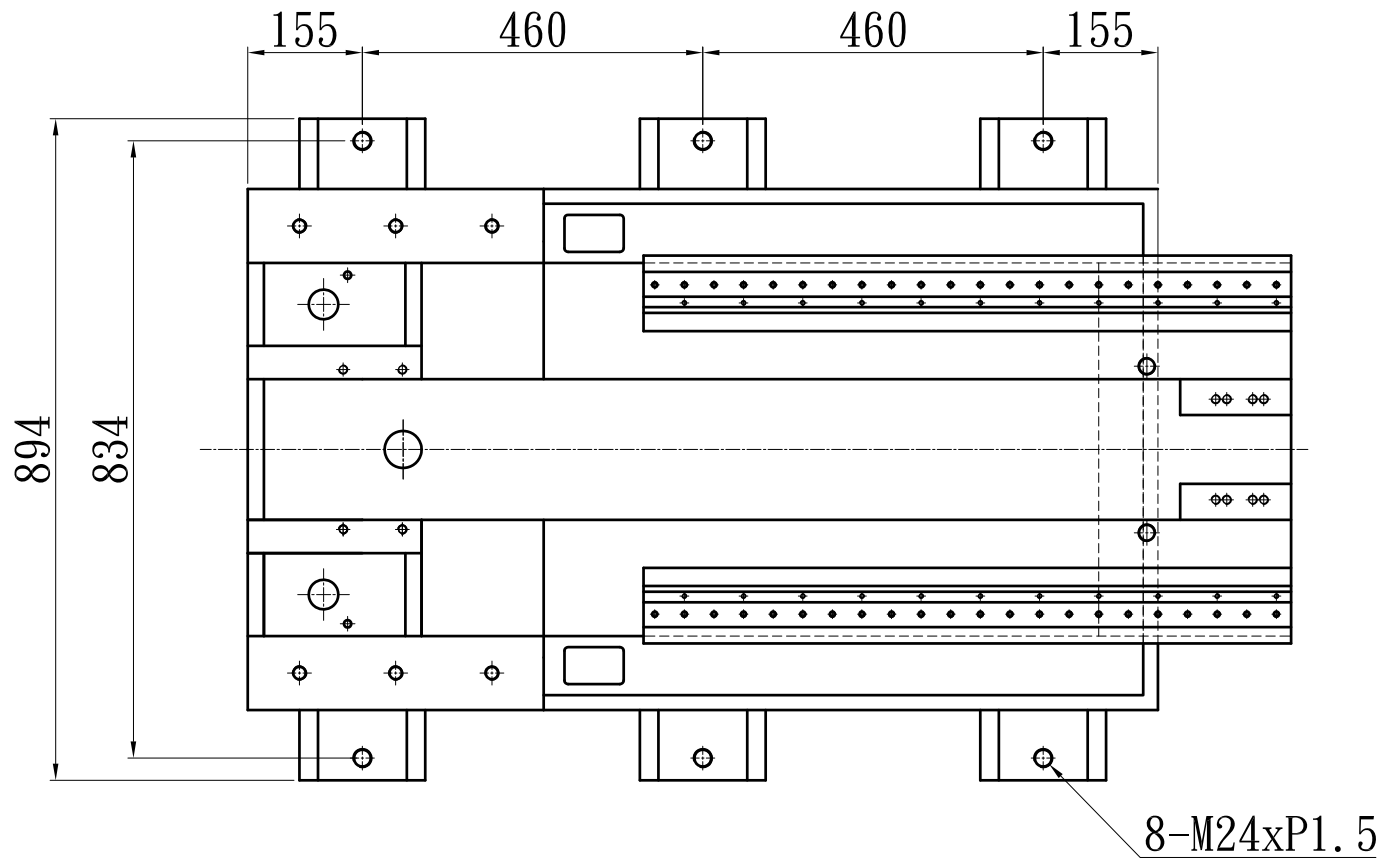

Leaderway Machinery Co. Ltd.

Scale 1:1	Drawing Name VMC-2516 地基圖			Page 1/1	A4
	Drawn	Name AMY	Date 97.12.04	Draw No. -----	
	Control	----	----		

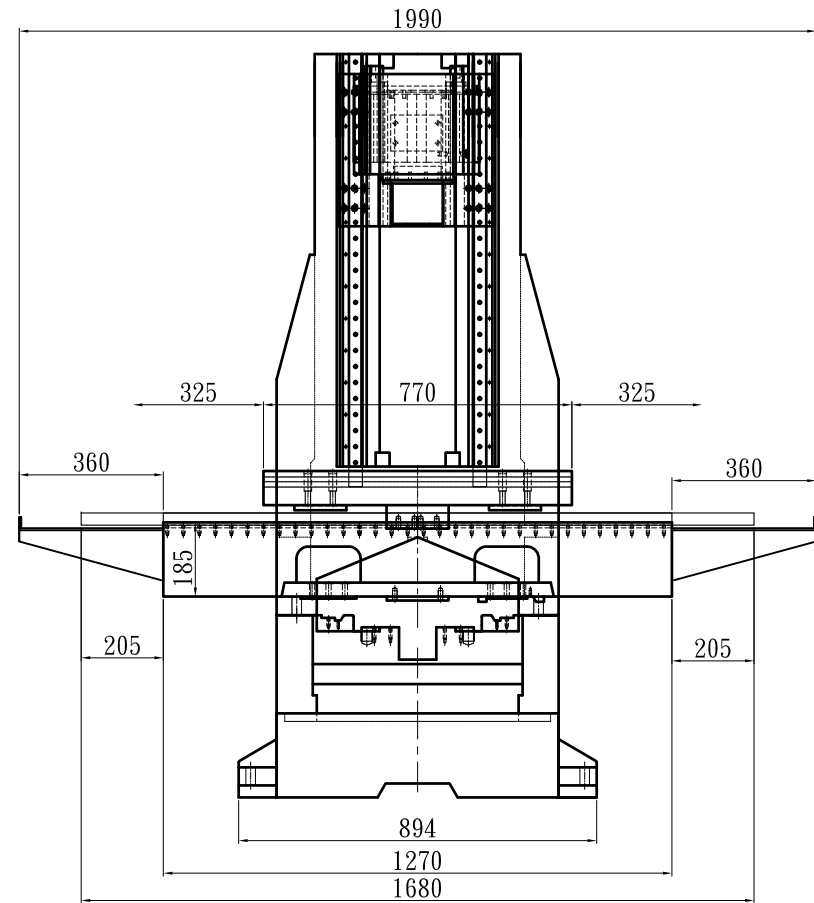
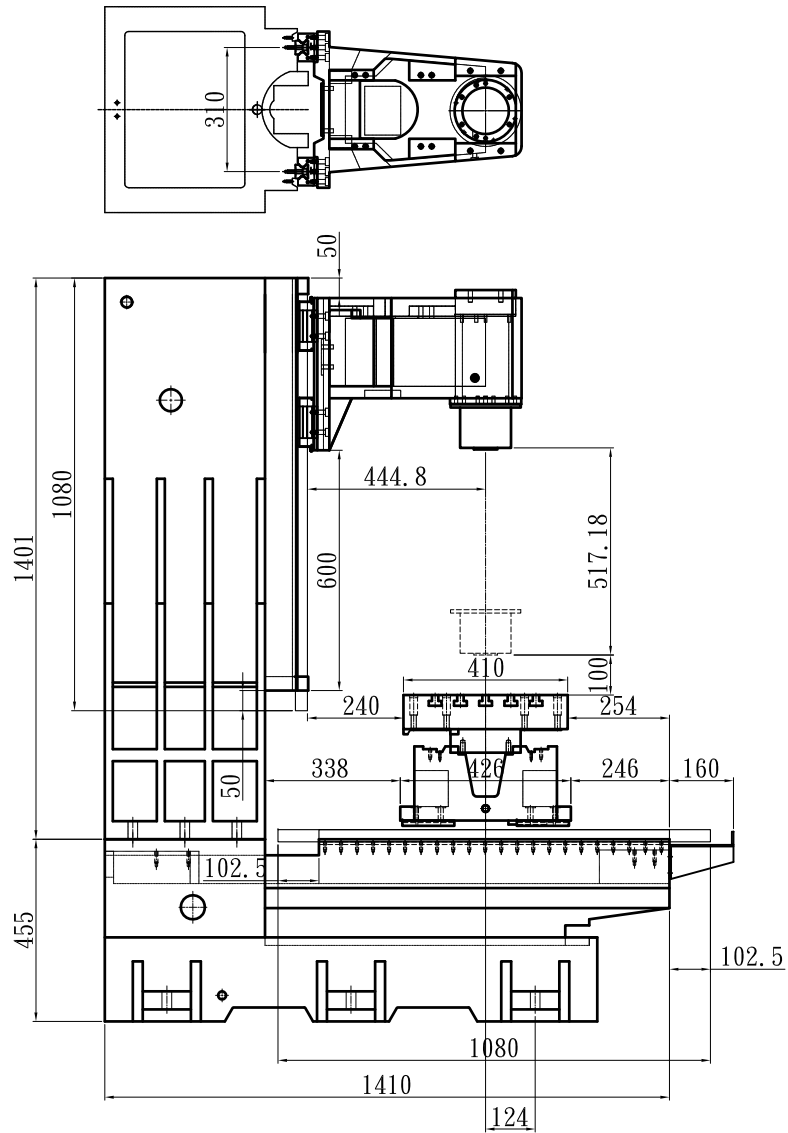

<b>Leaderway Machinery Co. Ltd.</b>					
Scale <b>1:1</b>	Drawing Name <b>VMC-2516 地基圖</b>				Page <b>1/1</b>
	Drawn Name <b>AMY</b>	Date <b>97.12.04</b>	Draw No. -----		
	Control -----	-----	-----		

**A4**

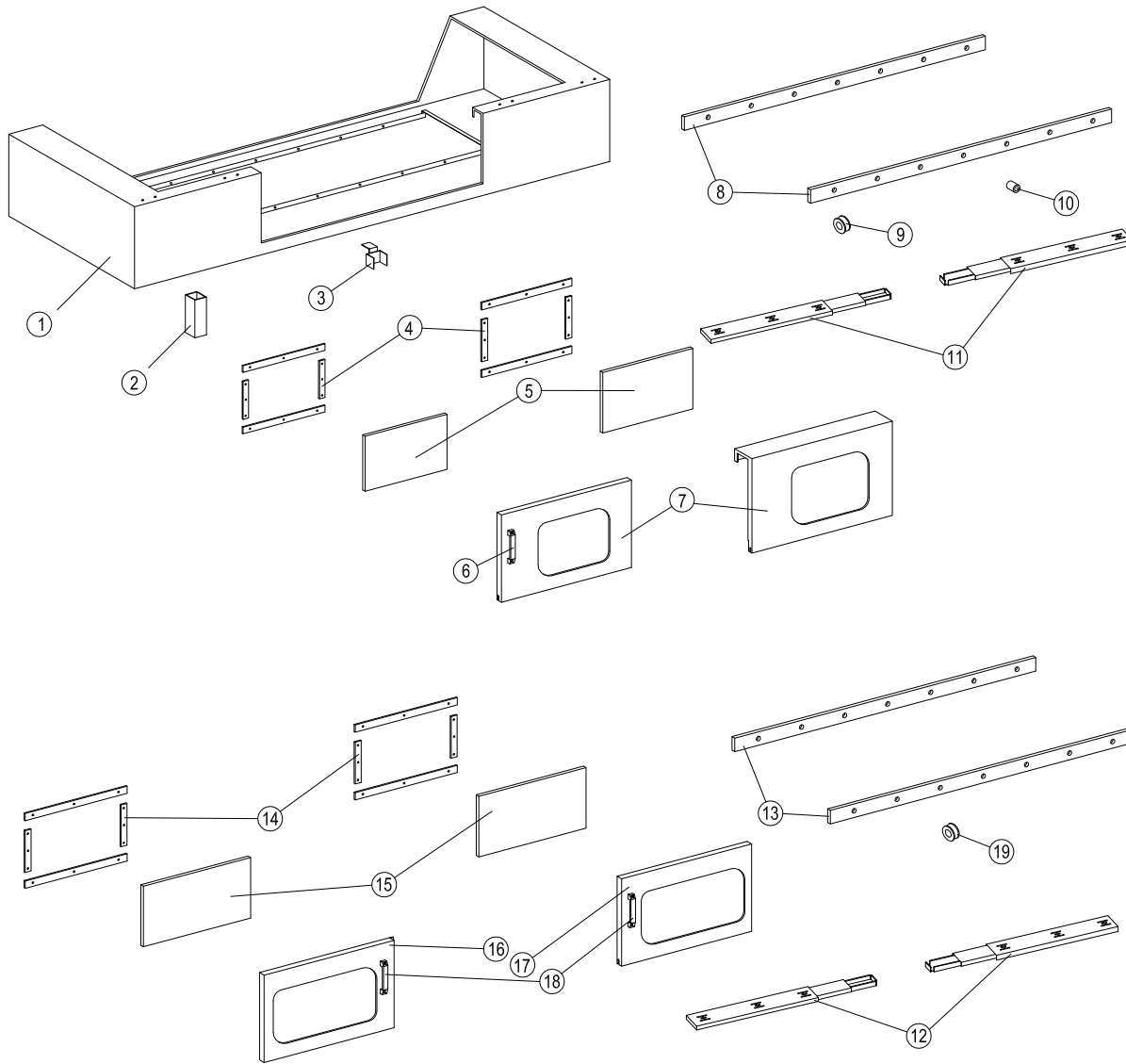

ITEM	DESCRIPTION	Q'TY
①	工作台護罩	1
②	套 管	1
③	固定門座	1
④	壓 條	8
⑤	壓 克 力	7
⑥	弓 形 手 把	1
⑦	活 動 門	2
⑧	軌 道	2
⑨	滑 輪	4
⑩	套 筒	10
⑪	三 節 滑 軌	2
⑫	三 節 滑 軌	2
⑬	軌 道	2
⑭	壓 條	8
⑮	壓 克 力	2
⑯	左 側 活 動 門	1
⑰	右 側 活 動 門	1
⑱	弓 形 手 把	2
⑲	滑 輪	4
⑳		
㉑		
㉒		
㉓		
㉔		

# Leaderway Machinery Co. Ltd.

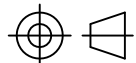
Scale 1:1	Drawing Name VMC-2516 單開，雙開 工作台護罩板金圖			Page 1/1	A4
	Drawn	Name AMY	Date 97.12.04	Draw No. -----	
	Control	----	----		

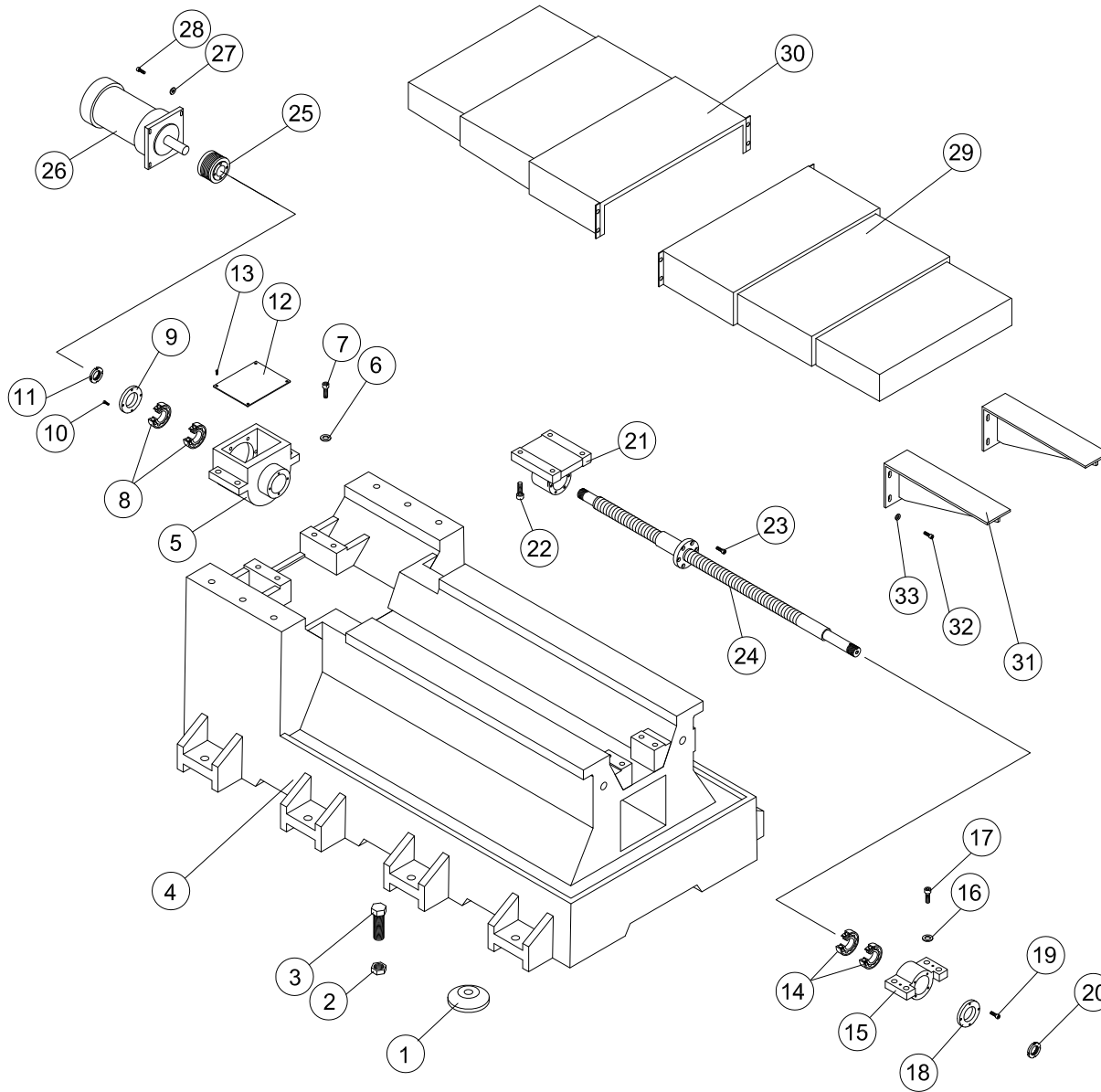

ITEM	DESCRIPTION	Q'TY	ITEM	DESCRIPTION	Q'TY
①	Leveling Pad	8	②⑤	Coupling	1
②	Nut	8	②⑥	Motor	1
③	Screw (M24*P1.5)	8	②⑦	Washer	4
④	Base	1	②⑧	Screw	4
⑤	Bearing Bracket	1	②⑨	Front Way Cover	1
⑥	Washer	4	③⑩	Rear Way Cover	1
⑦	Screw (M4)	4	③⑪	Cover Brace	2
⑧	Bearing (25T AC62)	2	③⑫	Washer	6
⑨	Bearing Cover	1	③⑬	Screw (M6)	6
⑩	Screw (M6*20)	4	③⑭		
⑪	Nut	1	③⑮		
⑫	Cover	1	③⑯		
⑬	Screw	4	③⑰		
⑭	Bearing (25T AC62)	2	③⑱		
⑮	Bearing Bracket	1	③⑲		
⑯	Washer	4	④⑰		
⑰	Screw (M12)	4	④⑱		
⑱	Bearing Cover	1	④⑲		
⑲	Screw (M6*20)	4	④⑳		
⑳	Nut	1	④㉑		
㉑	Nut Bracket	1	④㉑		
㉒	Screw (M12)	4	④㉒		
㉓	Screw (M10)	4	④㉓		
㉔	Ballscrew	1	④㉔		

# Leaderway Machinery Co. Ltd.

Scale 1:1	Drawing Name VMC-2516 BASE			Page 1/1	A4
	Drawn	Name AMY	Date 97. 12. 04	Draw No. -----	
	Control	----	----		

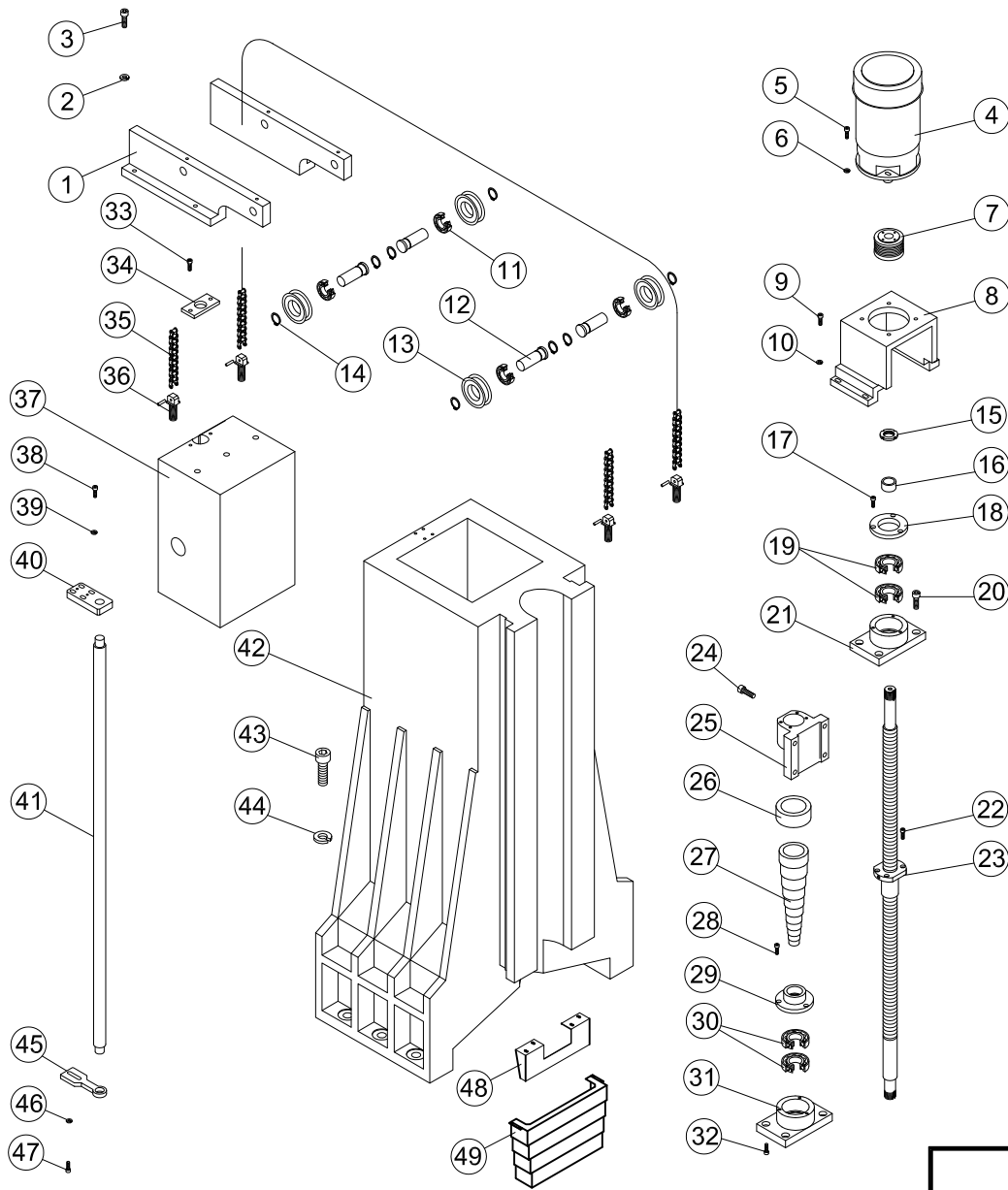

ITEM	DESCRIPTION	Q'TY	ITEM	DESCRIPTION	Q'TY	ITEM	DESCRIPTION	Q'TY
1	Chain Supporter	2	25	Nut Bracket	1	49	Cover	1
2	Washer	4	26	Upper Stay	1	50		
3	Screw (M5)	4	27	Ballscrew Chip Cover	1	51		
4	Motor	1	28	Screw (M6)	3	52		
5	Screw	4	29	Lower stay	1	53		
6	Washer	4	30	Bearing (#6025)	2	54		
7	Coupling	1	31	Bearing Bracket	1	55		
8	Motor seat	1	32	Screw (M10*35)	4	56		
9	Screw (M5)	4	33	Screw (M8)	4	57		
10	Washer	4	34	Buffer pad	1	58		
11	Bearing (#6205)	4	35	Chain	2	59		
12	Shaft	4	36	Screw (M16)	2	60		
13	Wheel	4	37	Count Balance	1			
14	C-Ring	8	38	Screw (M8)	4			
15	Nut	1	39	Washer	4			
16	Spacer	1	40	Guide pad	1			
17	Screw (M6*20)	3	41	Guide shaft	1			
18	Bearing Cover	1	42	Frame	1			
19	Bearing (#7025)	2	43	Screw (M24)	6			
20	Screw (M10*35)	4	44	Washer	6			
21	Bearing Bracket	1	45	Guide pad	1			
22	Screw (M10*25)	4	46	Washer	2			
23	Ballscrew	1	47	Screw (M8)	2			
24	Screw (M12*40)	4	48	Cover brace	1			

# Leaderway Machinery Co. Ltd.

Scale 1:1	Drawing Name VMC-2516 FRAME			Page 1/1	A4
	Drawn	Name AMY	Date 97.12.04	Draw No. -----	
	Control	----	----		

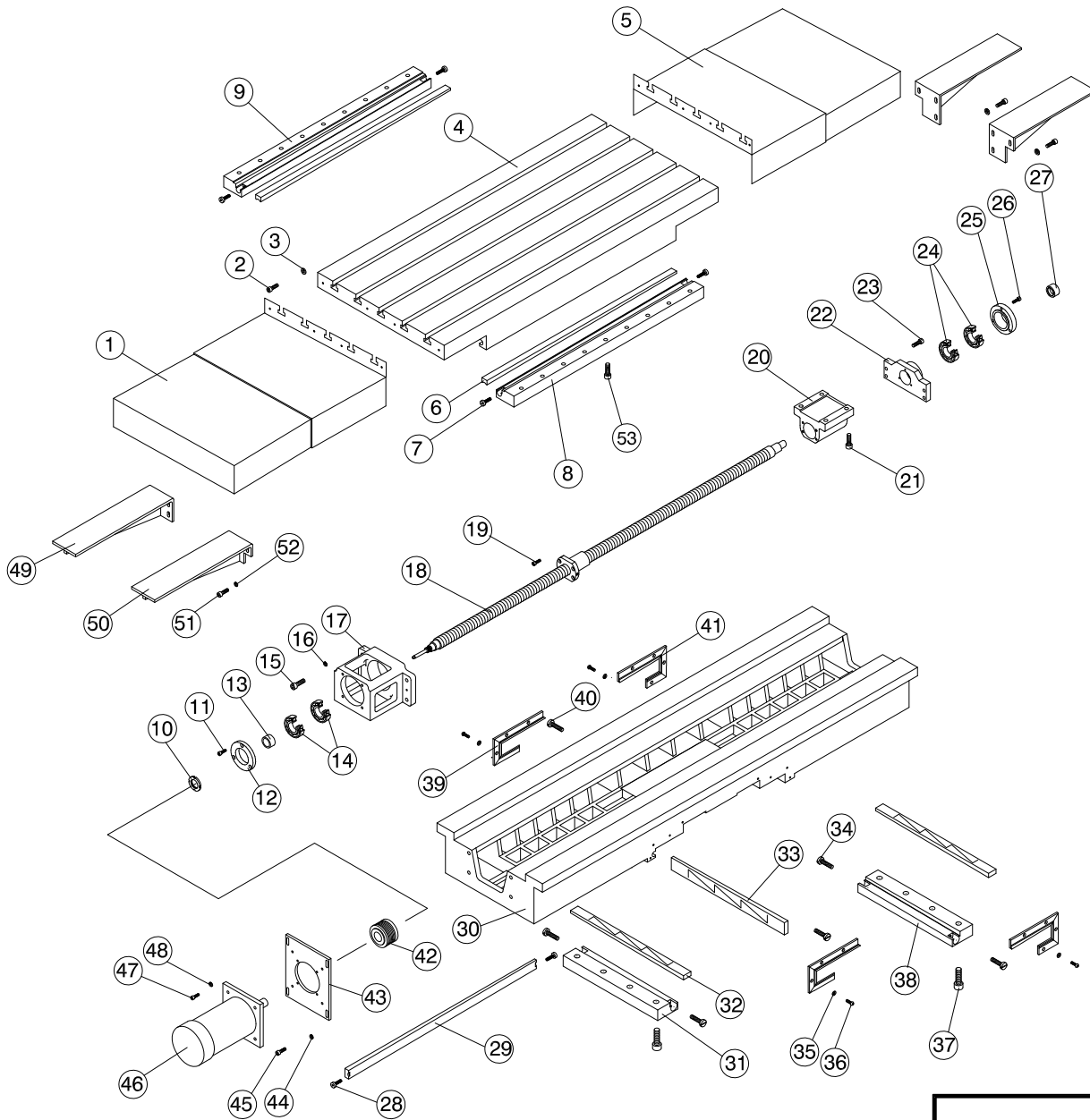

ITEM	DESCRIPTION	Q'TY	ITEM	DESCRIPTION	Q'TY	ITEM	DESCRIPTION	Q'TY
①	Left Way Cover	1	②⑤	Bearing Cover	1	④⑨	Cover brace	2
②	Screw (M6)	8	②⑥	Screw (M6*20)	3	⑤⑩	Cover brace	2
③	Washer	8	②⑦	Nut	1	⑤①	Screw (M6)	12
④	Table	1	②⑧	Gib Screw (5/16"*24NF)	2	⑤②	Washer	12
⑤	Right Way Cover	1	②⑨	Gib	1	⑤③	Screw (M12*40)	18
⑥	Gib	2	③⑩	Saddle	1	⑤④		
⑦	Gib Screw (5/16"*24NF)	4	③①	Bracket	1	⑤⑤		
⑧	Bracket	1	③②	Gib	2	⑤⑥		
⑨	Bracket	1	③③	Gib	1	⑤⑦		
⑩	Nut	1	③④	Gib Screw (5/16"*24NF)	2	⑤⑧		
⑪	Screw (M6*20)	3	③⑤	Washer	12	⑤⑨		
⑫	Bearing Cover	1	③⑥	Screw (M5)	12	⑥⑩		
⑬	Spacer	1	③⑦	Screw (M12*40)	8			
⑭	Bearing (25T AC62)	2	③⑧	Bracket	1			
⑮	Screw (M10*30)	4	③⑨	Wiper	2			
⑯	Washer	4	④⑩	Gib Screw (5/16"*24NF)	2			
⑰	Bearing Bracket	1	④①	Wiper	2			
⑱	Ball screw	1	④②	Coupling	1			
⑲	Screw (M10)	5	④③	Motor Plate	1			
⑳	Nut Bracket	1	④④	Washer	4			
㉑	Screw (M12)	4	④⑤	Screw (M8)	4			
㉒	Bearing Bracket	1	④⑥	Motor	1			
㉓	Screw (M8*30)	4	④⑦	Screw	4			
㉔	Bearing (#6205)	2	④⑧	Washer	4			

# Leaderway Machinery Co. Ltd.

Scale

1:1

Drawing Name

VMC-2516 TABLE

Page

1/1

A4

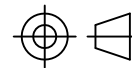

Drawn

Name

AMY

Date

97. 12. 04

Draw No.

Control

----

----

----

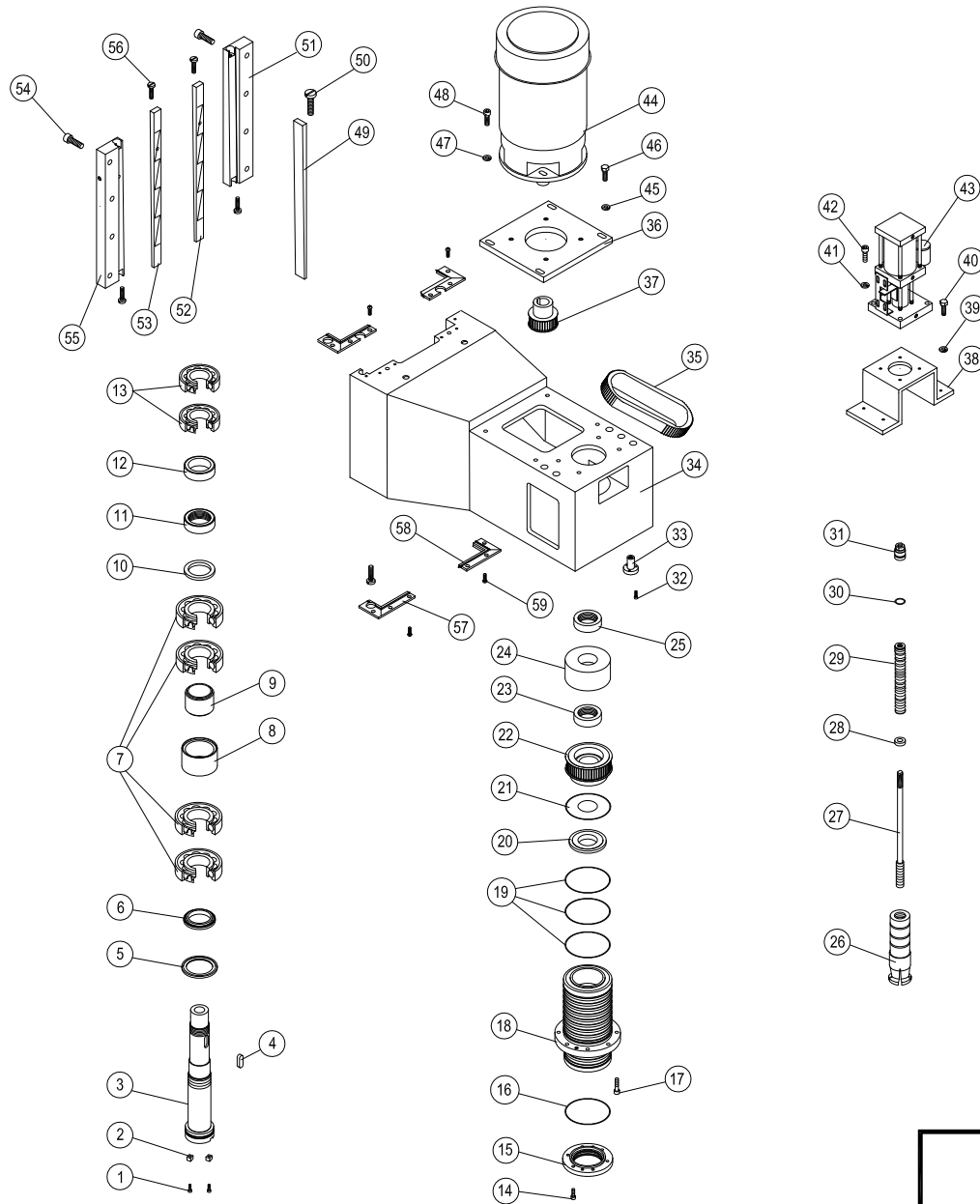

ITEM	DESCRIPTION	Q'TY	ITEM	DESCRIPTION	Q'TY	ITEM	DESCRIPTION	Q'TY
①	Screw (M6*16)	2	②⑤	Nut	1	④⑨	Gib	1
②	Key (16*16mm)	2	②⑥	4 Jaws	1	⑤⑩	Gib screw (5 /16"*24NF)	2
③	Spindle	1	②⑦	Draw Bar	1	⑤①	Bracket	1
④	Key	1	②⑧	Collar	1	⑤②	Gib	1
⑤	Seal (110*80mm)	1	②⑨	Disc Spring	1	⑤③	Gib	1
⑥	Seal (100*70)	1	③⑩	Collar	1	⑤④	Screw (M12*40)	10
⑦	Bearing (#7014)	4	③①	Nut	1	⑤⑤	Bracket	1
⑧	Spacer	1	③②	Screw (M6*16)	3	⑤⑥	Gib screw (5 /16"*24NF)	4
⑨	Spacer	1	③③	Coolant Nozzle	3	⑤⑦	Wiper	2
⑩	Nut	1	③④	Headstock	1	⑤⑧	Wiper	2
⑪	Collar	1	③⑤	Belt	1	⑤⑨	Screw (M5*10)	12
⑫	Collar	1	③⑥	Motor Plate	1	⑥⑩		
⑬	Bearing (#7013)	2	③⑦	Motor Piley (8YU-40T)	1			
⑭	Screw (M8*20)	8	③⑧	Cylinder seat	1			
⑮	Cover	1	③⑨	Washer	4			
⑯	O type ring (AS042)	1	④⑩	Screw (M8*30)	4			
⑰	Screw (M10*25)	8	④①	Washer	4			
⑱	Quill	1	④②	Screw (M8*30)	4			
⑲	O type ring (G140)	3	④③	Power Draw Bar	1			
⑳	Chip Cover	1	④④	Motor	1			
㉑	Chip Cover	1	④⑤	Washer	4			
㉒	Pulley (8YU40T)	1	④⑥	Screw (M12*20)	4			
㉓	Nut	1	④⑦	Washer	4			
㉔	Cover	1	④⑧	Screw	4			

# Leaderway Machinery Co. Ltd.

Scale 1:1	Drawing Name VMC-2516 HEADSTOCK			Page 1/1	A4
	Drawn	Name AMY	Date 97. 12. 04	Draw No. -----	
	Control	----	----		