



Leaderway *DOUBLE COLUMN MACHING CENTER*

DOUBLE COLUMN MACHING CENTER

PARTS LIST

LX-B

LEADERWAY CNC TECHNOLOGIES CO., LTD.
NO. 36, Ln. 211, Taiming Rd.,
Wuri Dist, TAICHUNG 41468, TAIWAN
TEL: +886-4-2335-0711
FAX: +886-4-2335-0986



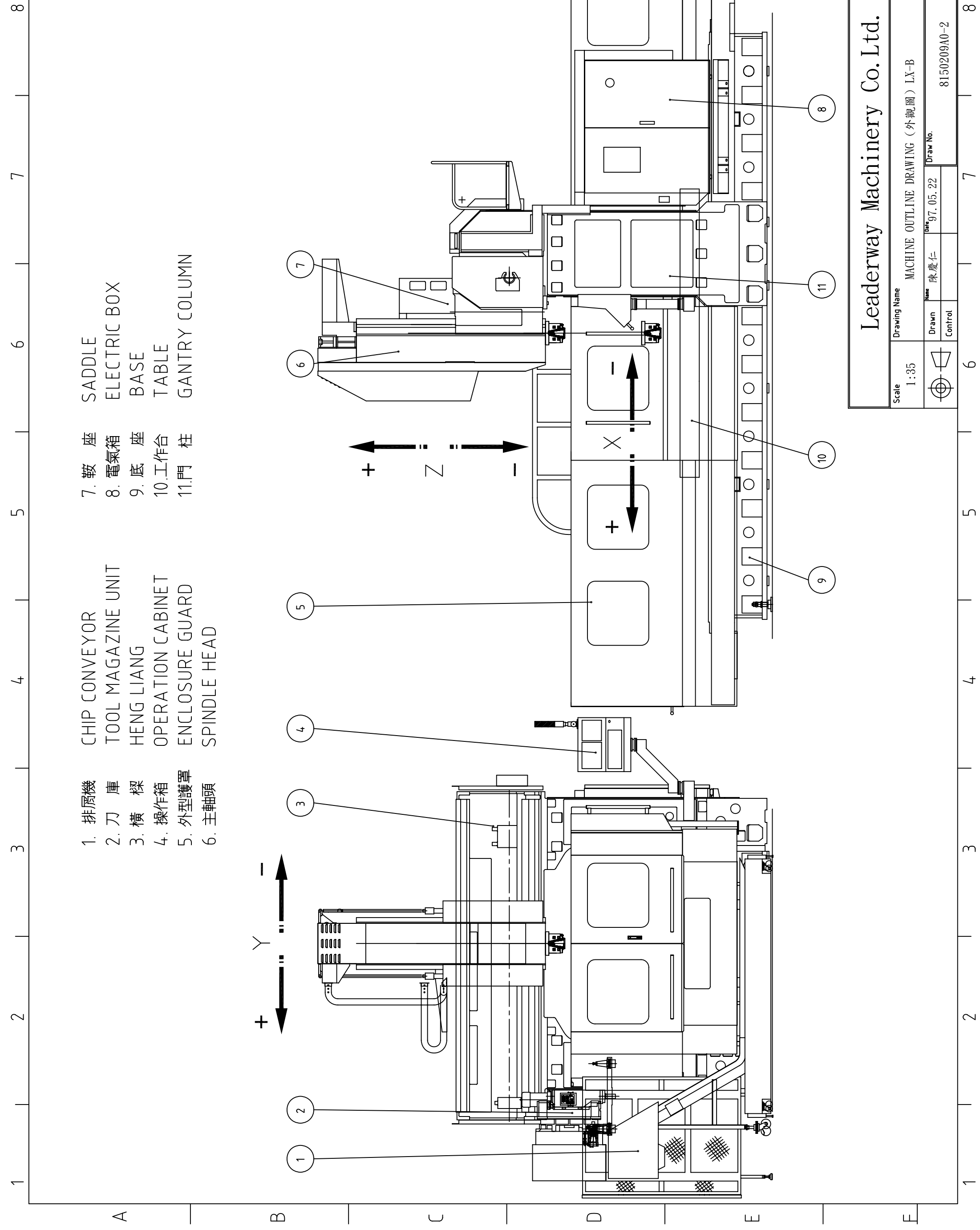

- | | | | |
|---------|--------------------|---------|---------------|
| 1. 排屑機 | CHIP CONVEYOR | 7. 鞍座 | SADDLE |
| 2. 刀庫 | TOOL MAGAZINE UNIT | 8. 電氣箱 | ELECTRIC BOX |
| 3. 橫樑 | HENG LIANG | 9. 底座 | BASE |
| 4. 操作箱 | OPERATION CABINET | 10. 工作台 | TABLE |
| 5. 外型護罩 | ENCLOSURE GUARD | 11. 門柱 | GANTRY COLUMN |
| 6. 主軸頭 | SPINDLE HEAD | | |

Leaderway Machinery Co. Ltd.

Scale	1:35	Drawing Name	MACHINE OUTLINE DRAWING (外觀圖) LX-B	Page	1/1
		Drawn	陳慶仁	Date	97.05.22
		Control		Draw No.	8150209A0-2

1 2 3 4 5 6 7 8

1 2 3 4 5 6 7 8

A B C D E F

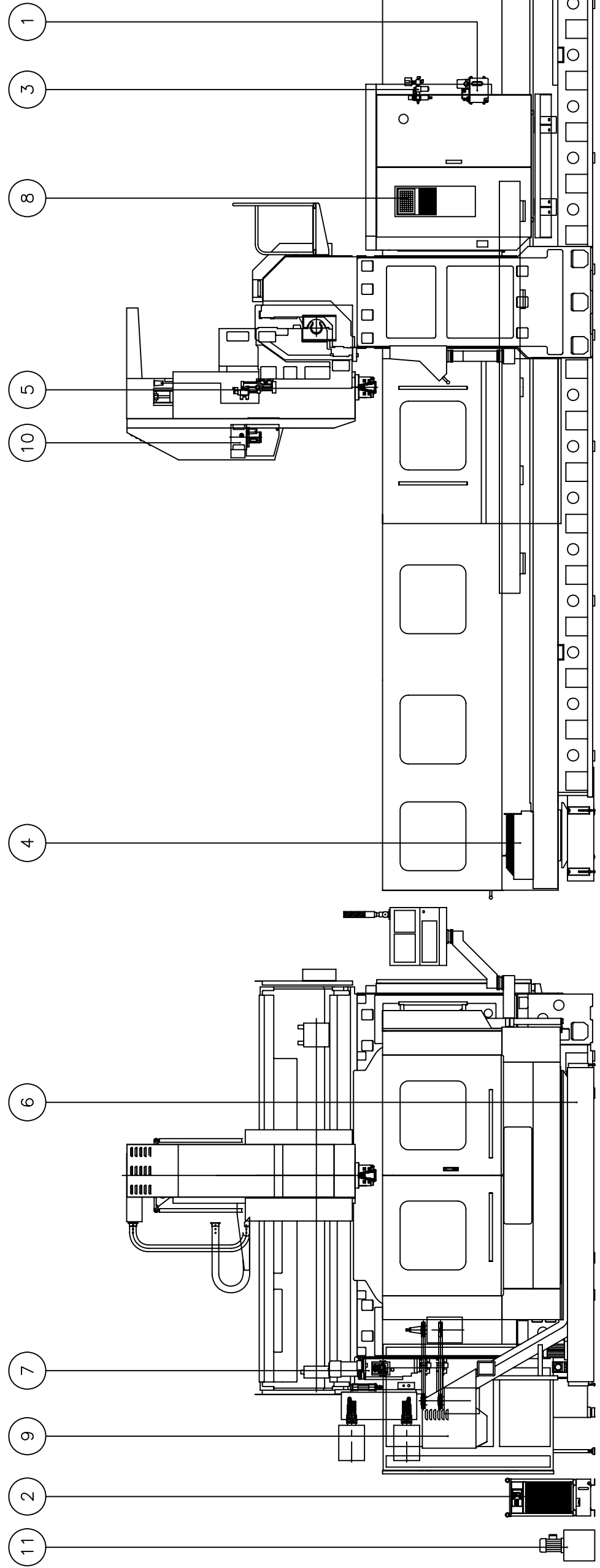

DAILY MAINTENANCE	1	2	3	4	5	6	7	8	9	10	11
OPERATING HOURS											
MACHINE COMPONENT	LUBRICATION UNIT	REFRIGERATION UNIT	AIR TREATMENT UNIT	X-Y-Z TELESCOPIC COVER	FIGHTING KNIFE DEVICE	COOLING UNIT	TOOL MAGAZIN	HEAT EXCHANGER	CHIP CONVEYOR	GEAR BOX	HYDRAULIC UNIT
POINT N°	1 2 3	1 2 3	1 2 3	1	1 2	1 2 3	1	1	1	1 2 3	1 2 3
MAINTENANCE SYMBOL											
CHECK ITEMS											
MANUALLY LUBRICATION											
CHECK	8		8								
CHANGE											
CLEAN		40						200			
CLEAN AND LUBRICATE				200					200		
CHECK AND FILL	8	200	40		40	8				8	200
DRAIN AND REFILL											
TYPE OF LUBRICANT (STANDARD ISO 3468)	VG-68	VG-22	VG-22	VG-68	VG-32	②	Mob#630		L-CKC220	VG-32	VG-32

ATTENTION: CLEAN ALL THESE POINTS THOROUGHLY BEFORE LUBRICATION
 ② MOBILCUT 232-CONCENTRATION 7% MALL (PLEASE REFER TO END USER'S SUPPLIER MANUAL)
 The machine part accessories listed above does not exactly accord with your sales order. Please refer to your sales order if any machine parts accessories differences.

Leaderway Machinery Co. Ltd.

Scale 1:45
 Drawing Name THE SKETCH OF DAILY MAINTENANCE
 Page 1/1
 A3

Drawn 卜珉云
 Control 審核
 Date 99.08.20
 Draw No. 8150205B0 (LX-B系列)
 yy. mm. dd

1 2 3 4 5 6 7 8

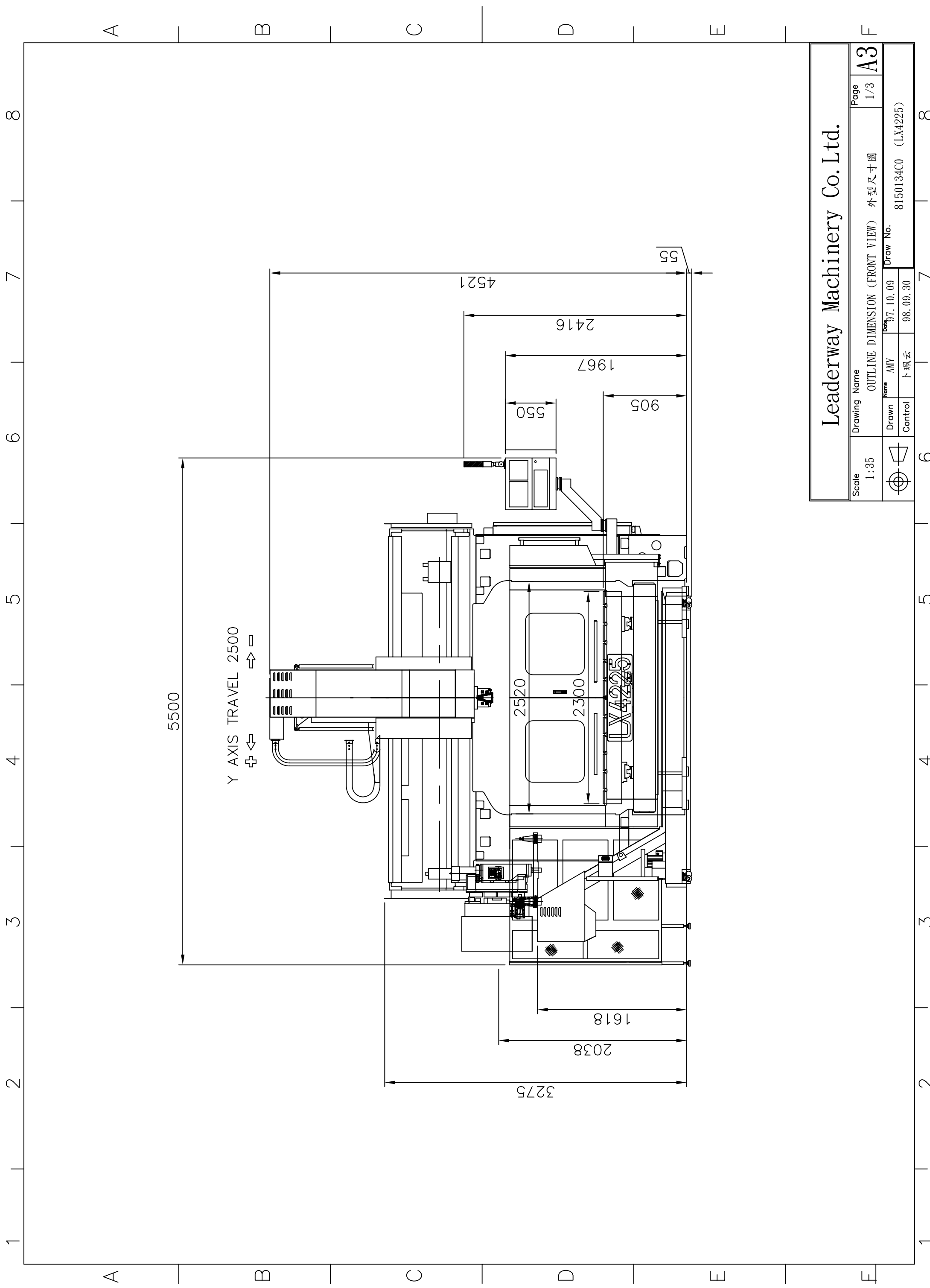

Leaderway Machinery Co. Ltd.

Scale	1:35	Drawing Name	OUTLINE DIMENSION (FRONT VIEW) 外型尺寸圖	Page	1/3
		Name	卜珮云	Drawn	Control
		Date	97.10.09	Draw No.	8150134C0 (LX4225)
			98.09.30		

A3

1 2 3 4 5 6 7 8

A B C D E

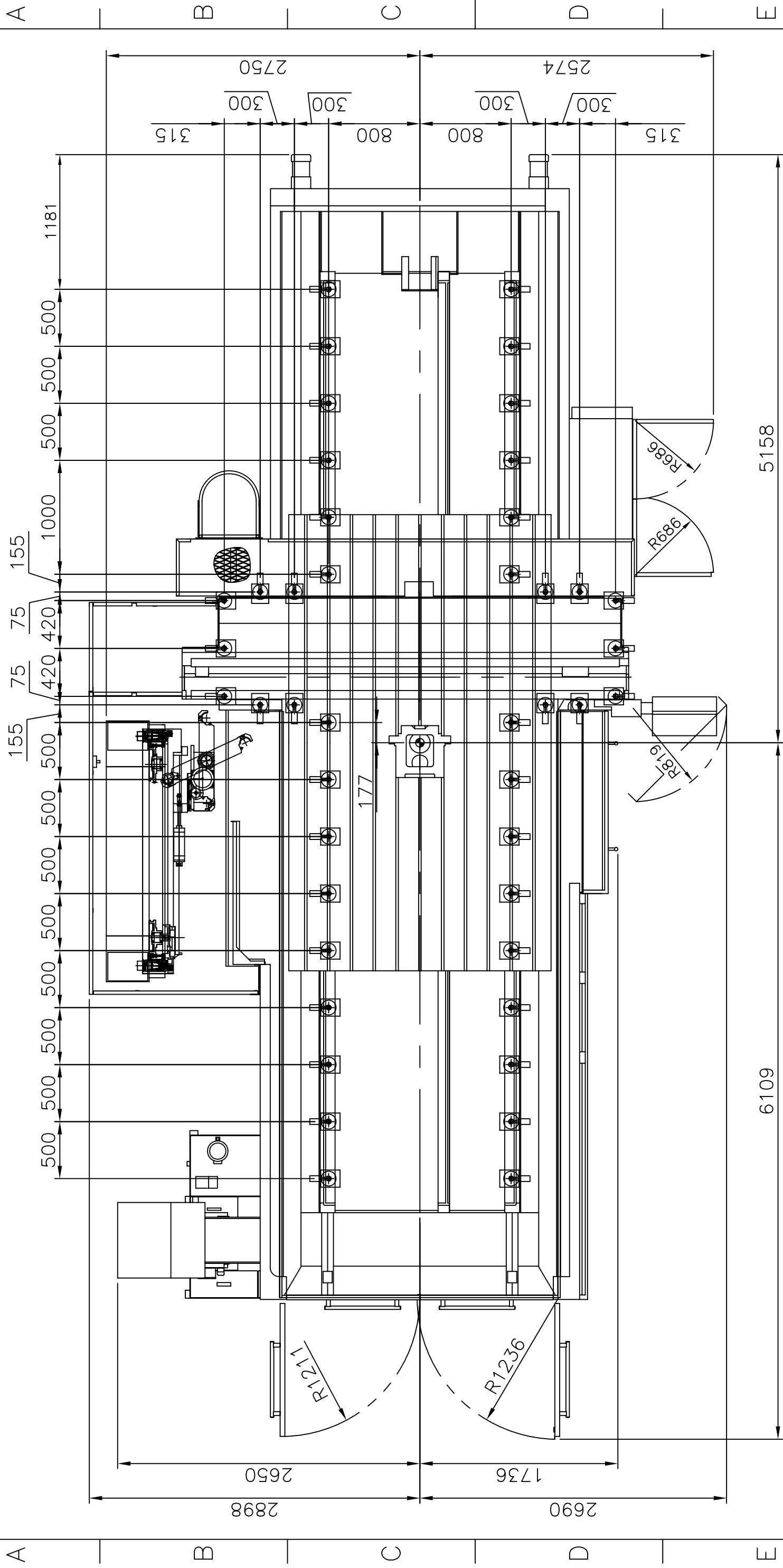

Leaderway Machinery Co. Ltd.

Scale	1:35	Drawing Name	OUTLINE DIMENSION (TOP VIEW) 外型尺寸圖	Page	2/3
Drawn	卜珮云	Name	AMY	Draw No.	8150134C0 (LX4225)
Control		Date	97.10.09		
			98.09.30		

F A3

1 2 3 4 5 6 7 8

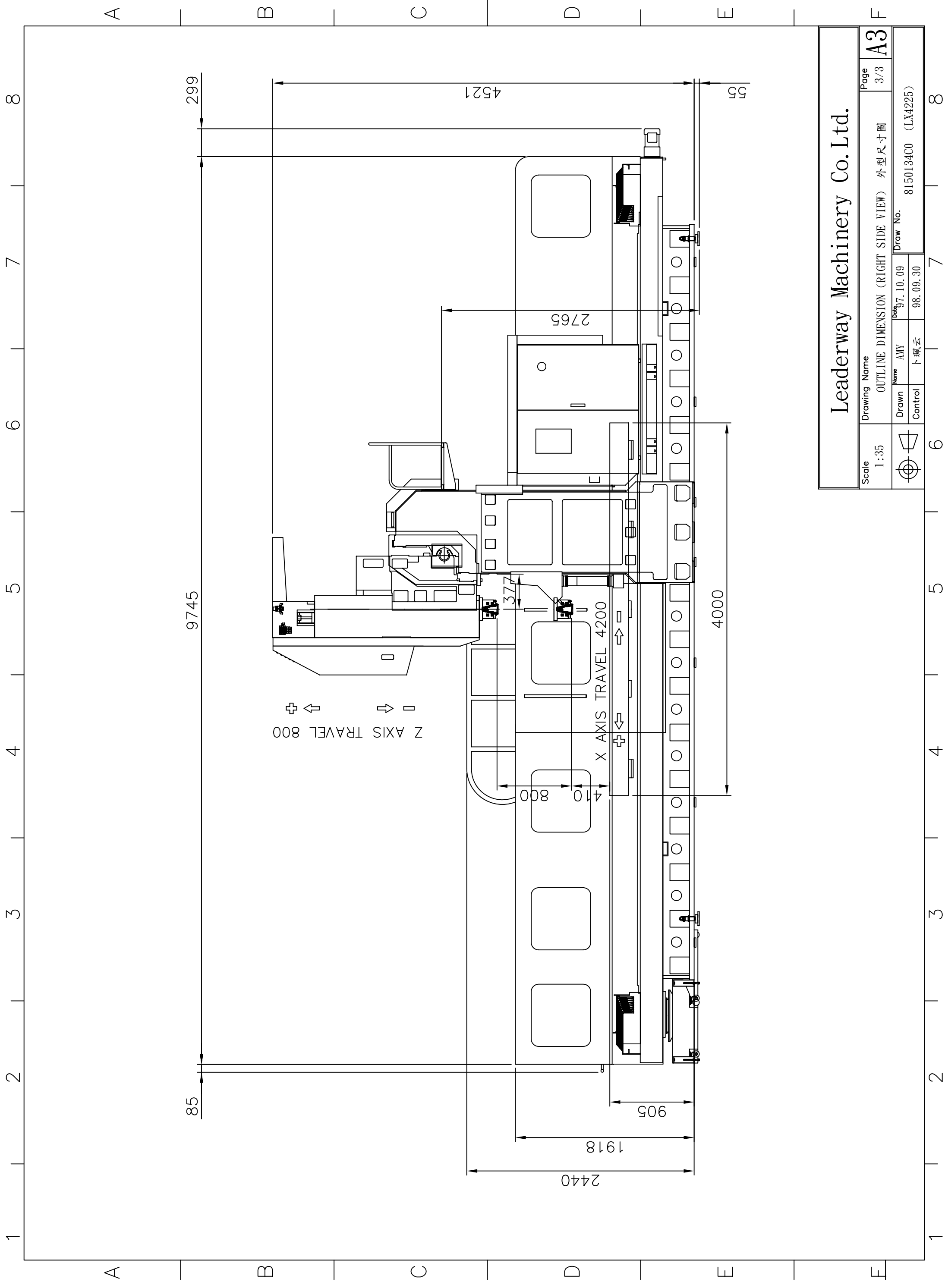

Leaderway Machinery Co. Ltd.		Drawing Name		Page	
		OUTLINE DIMENSION (RIGHT SIDE VIEW) 外型尺寸圖		3/3	
Scale	1:35	Drawn	AMY	Draw No.	8150134C0 (LX4225)
		Control	卜珮云	Date	97.10.09
					98.09.30

F A3

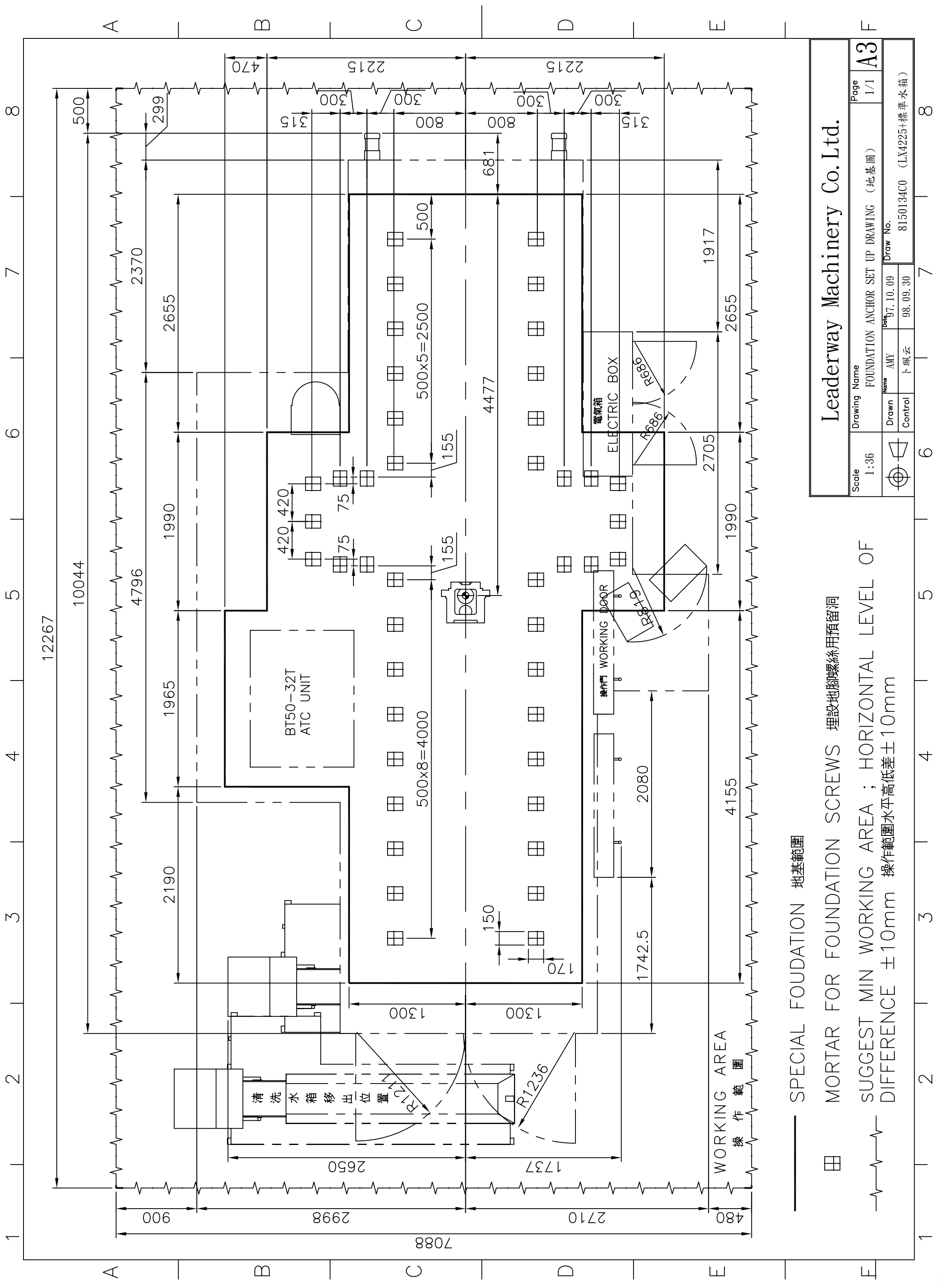

— SPECIAL FOUNDATION 地基範圍

田 MORTAR FOR FOUNDATION SCREWS 埋設地腳螺絲預留洞

— SUGGEST MIN WORKING AREA ; HORIZONTAL LEVEL OF DIFFERENCE ±10mm 操作範圍水平高低差±10mm

Drawing Name		Page	
FOUNDATION ANCHOR SET UP DRAWING (地基圖)		1/1	
Scale		A3	
1:36			
Drawn	Check	Draw No.	
AMY	7.10.09	81501340	(LX425+標準水箱)
Control	卜珮云	98.09.30	

Leaderway Machinery Co. Ltd.

1 2 3 4 5 6 7 8

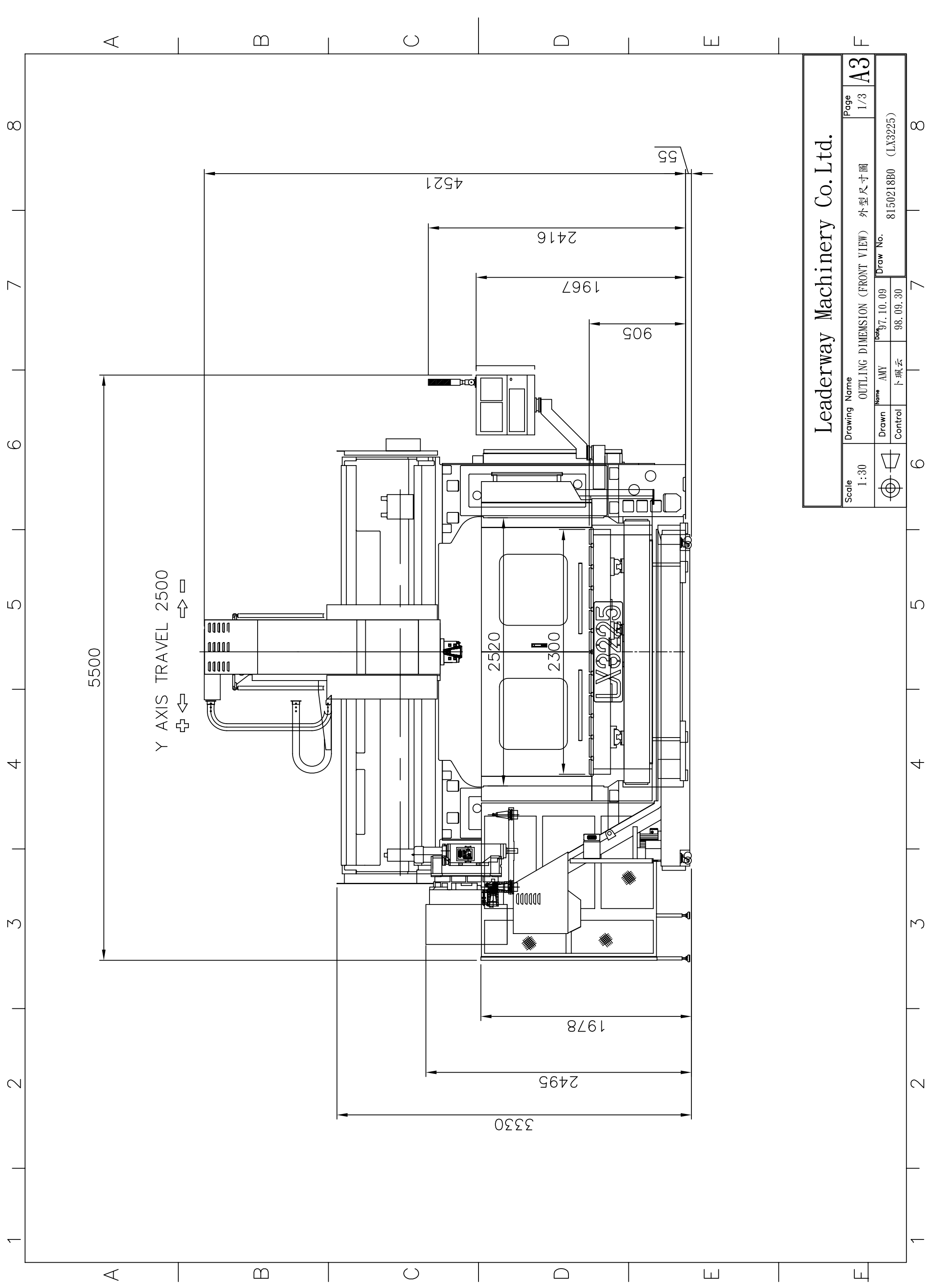

Leaderway Machinery Co. Ltd.

Scale	1:30	Drawing Name	OUTLING DIMENSION (FRONT VIEW) 外型尺寸圖	Page	1/3
	Drawn	Name	AMY	Date	97.10.09
	Control	Name	卜珮云	Draw No.	815021880 (LX3225)

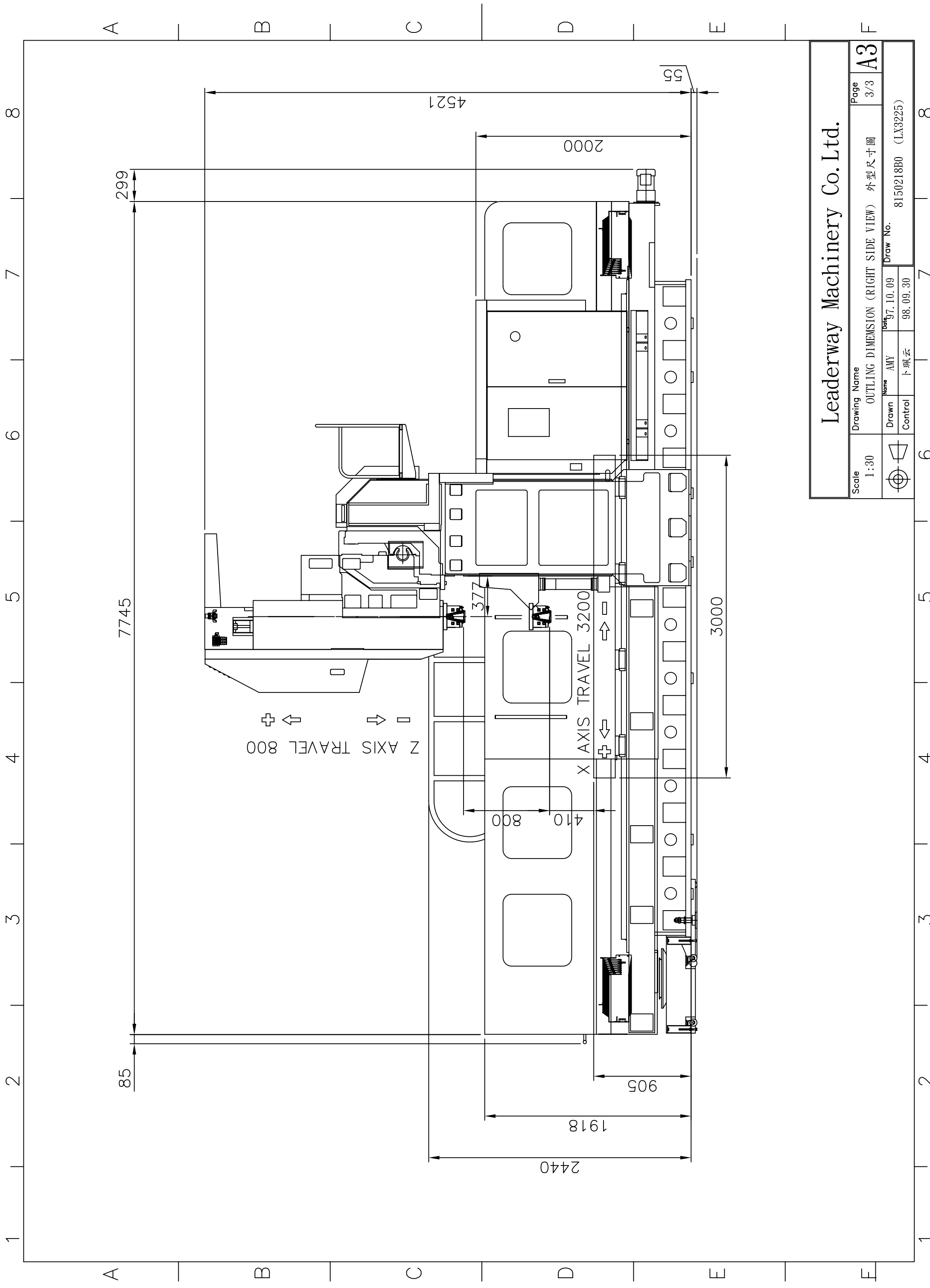

Leaderway Machinery Co. Ltd.

Scale	1:30	Drawing Name	OUTLING DIMENSION (RIGHT SIDE VIEW) 外型尺寸圖	Page	3/3
		Drawn	Control	Date	97.10.09
		Name	AMY	Draw No.	8150218B0 (LX3225)
			卜珮云		98.09.30

A3

F

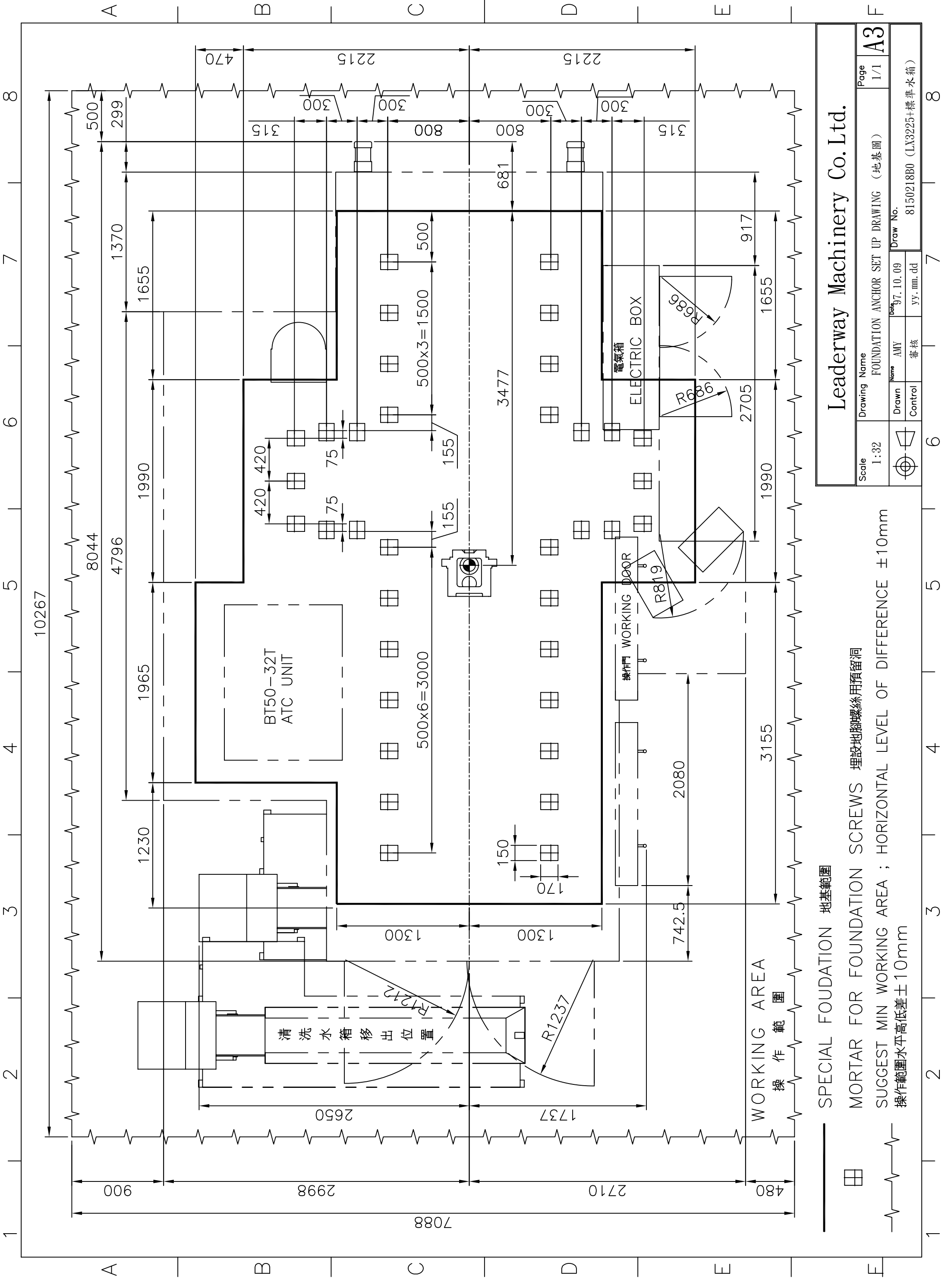

Leaderway Machinery Co. Ltd.

Scale	1:32	Drawing Name	FOUNDATION ANCHOR SET UP DRAWING (地基圖)	Page	1/1
		Name	AMY	Date	97.10.09
		Drawn	審核	Draw No.	8150218B0 (LA3225+標準水箱)
		Control		yy.mm.dd	

SPECIAL FOUNDATION 地基範圍

MORTAR FOR FOUNDATION SCREWS 埋設地腳螺絲用預留洞

SUGGEST MIN WORKING AREA ; HORIZONTAL LEVEL OF DIFFERENCE ±10mm
操作範圍水平高低差±10mm

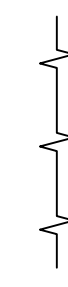

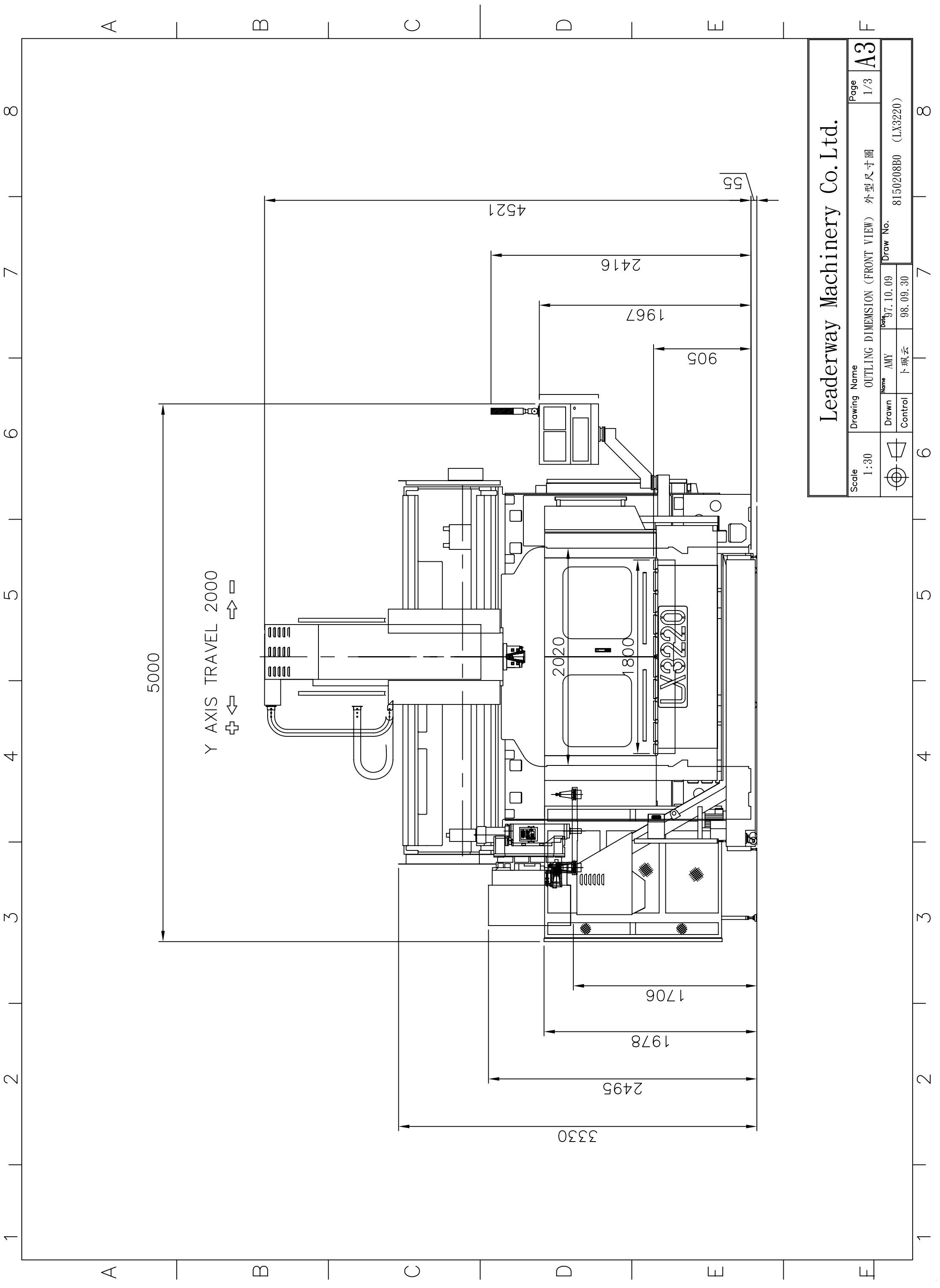

Leaderway Machinery Co. Ltd.

Scale	1:30	Drawing Name	OUTLING DIMENSION (FRONT VIEW)	外型尺寸圖	Page	1/3	
	Drawn	AMY	Date	97.10.09	Draw No.	8150208B0 (LX3220)	
	Control	卜珮云	Date	98.09.30			
						Sheet	A3

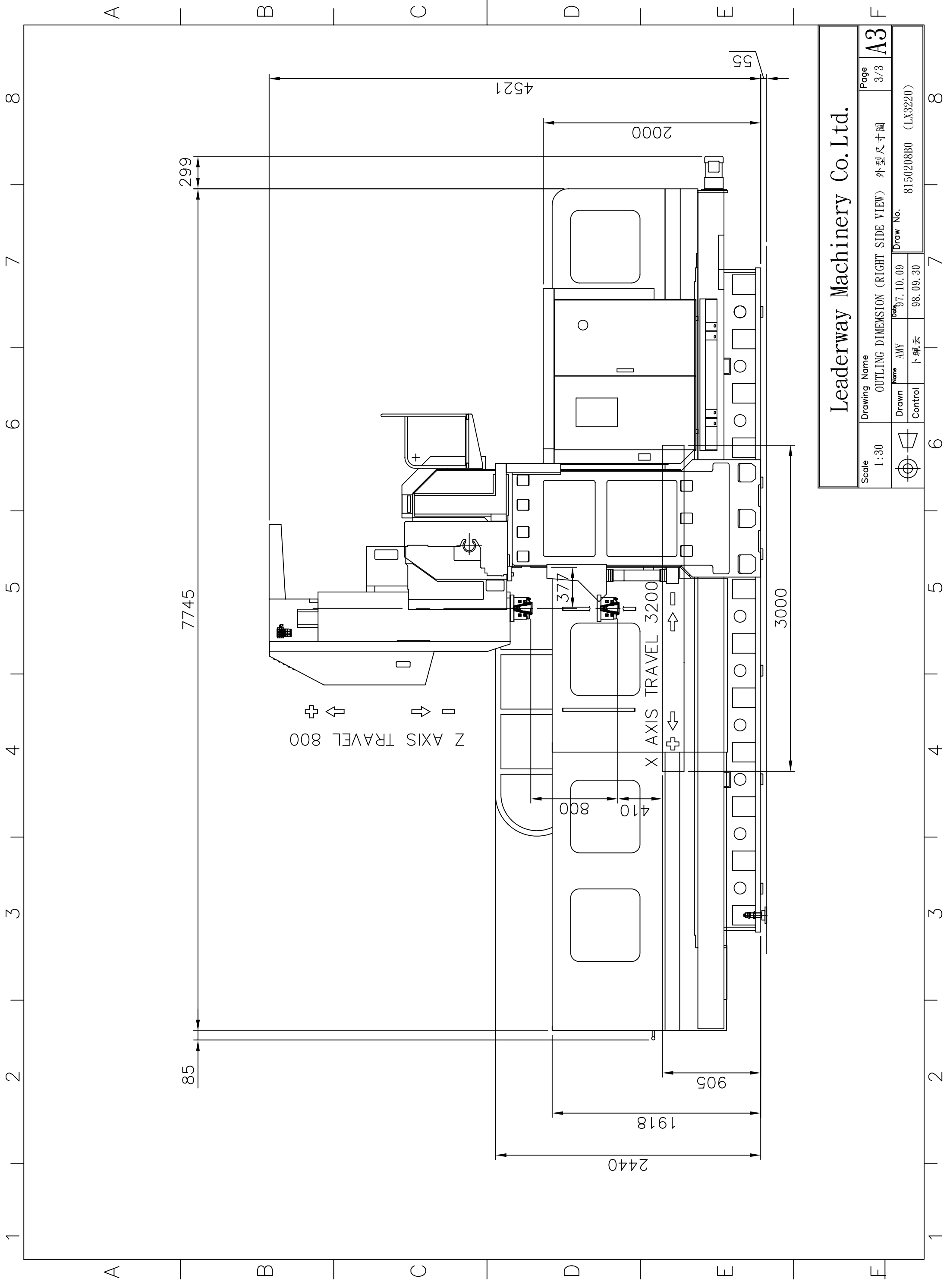

Leaderway Machinery Co. Ltd.

Scale	1:30	Drawing Name	OUTLING DIMENSION (RIGHT SIDE VIEW)	Page	3/3
		Name	AMY	Draw No.	8150208B0 (LX3220)
		Control	卜珮云	Date	97.10.09
				Date	98.09.30

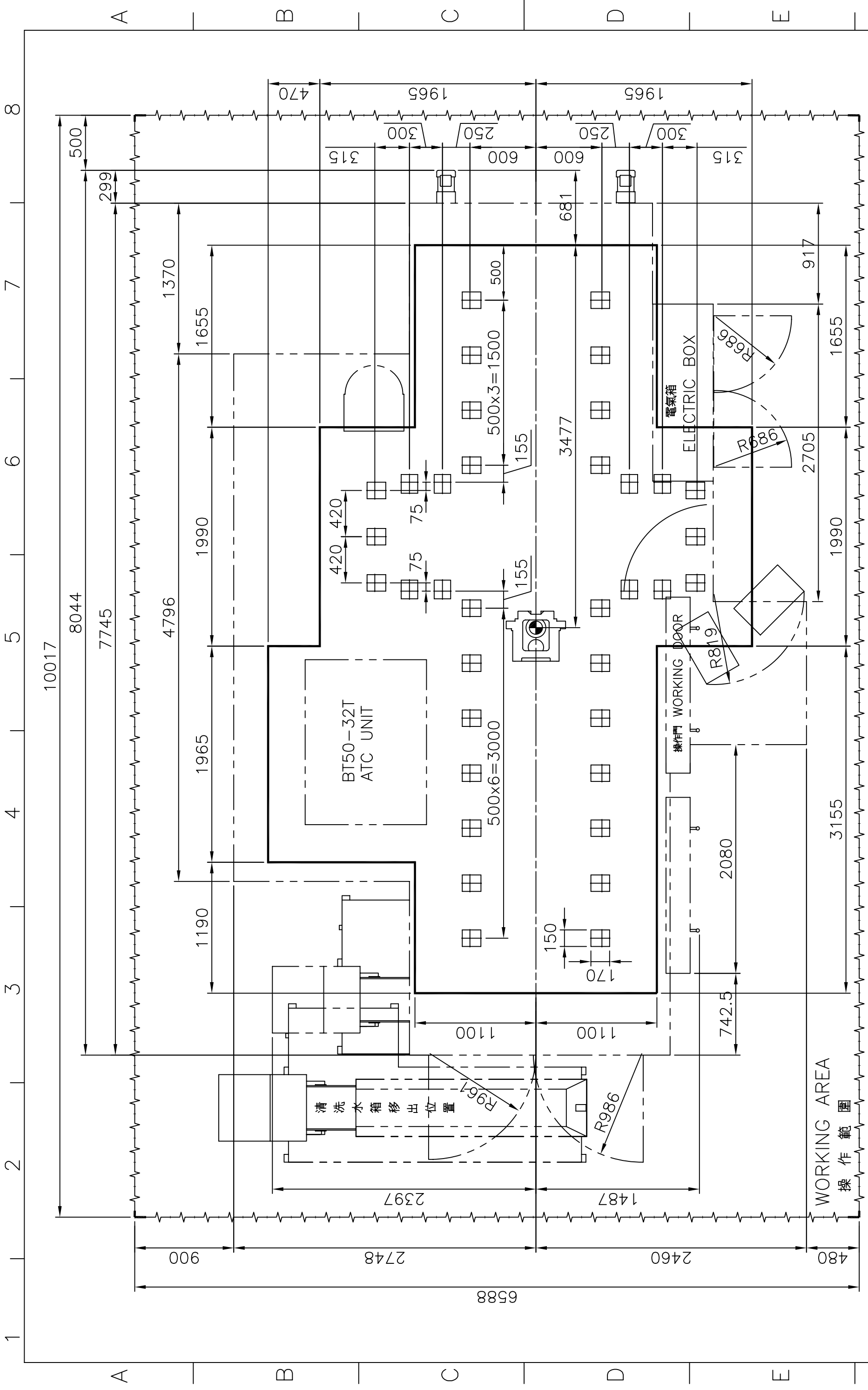

Scale 1:32		Drawing Name FOUNDATION ANCHOR SET UP DRAWING (地基圖)		Page 1/1
		Name AMY		Draw No. 8150208B0 (LX3220+標準水箱)
Control		Date 97.10.09		Draw No. 8150208B0 (LX3220+標準水箱)

Leaderway Machinery Co. Ltd.

SPECIAL FOUDATION 地基範圍

MORTAR FOR FOUNDATION SCREWS 埋設地腳螺絲用預留洞

SUGGEST MIN WORKING AREA ; HORIZONTAL LEVEL OF DIFFERENCE ±10mm
操作範圍水平高低差±10mm

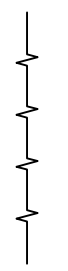

A=350(V450/V650(V650HSM)/V33i/V42i)
 A=500(V1100/MV1100S/MV1100D/MV1300D/LX8/LX10)
 A=700(LX1600/LX2200)
 A=1000(LX-B.....)

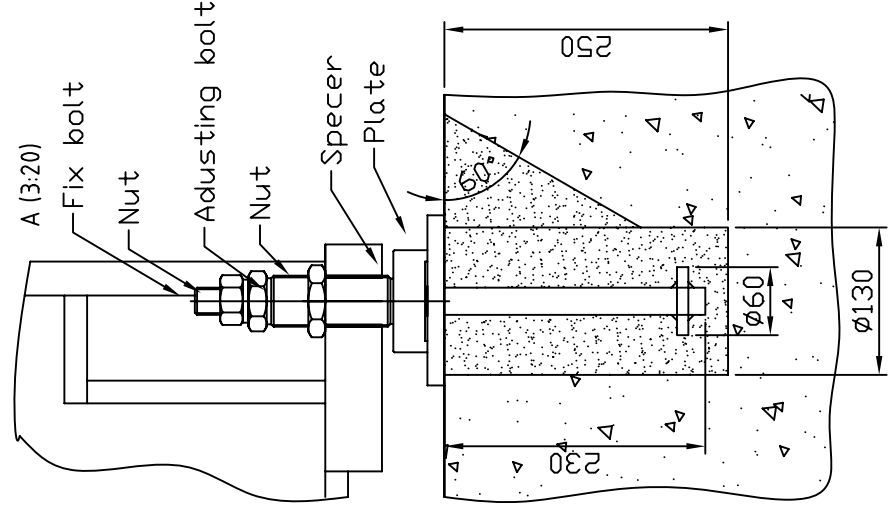
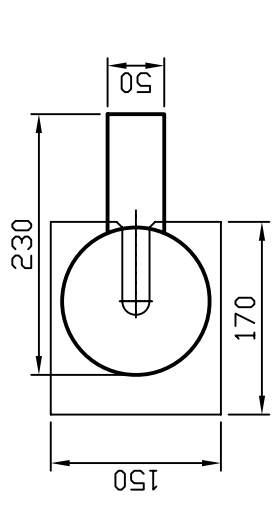
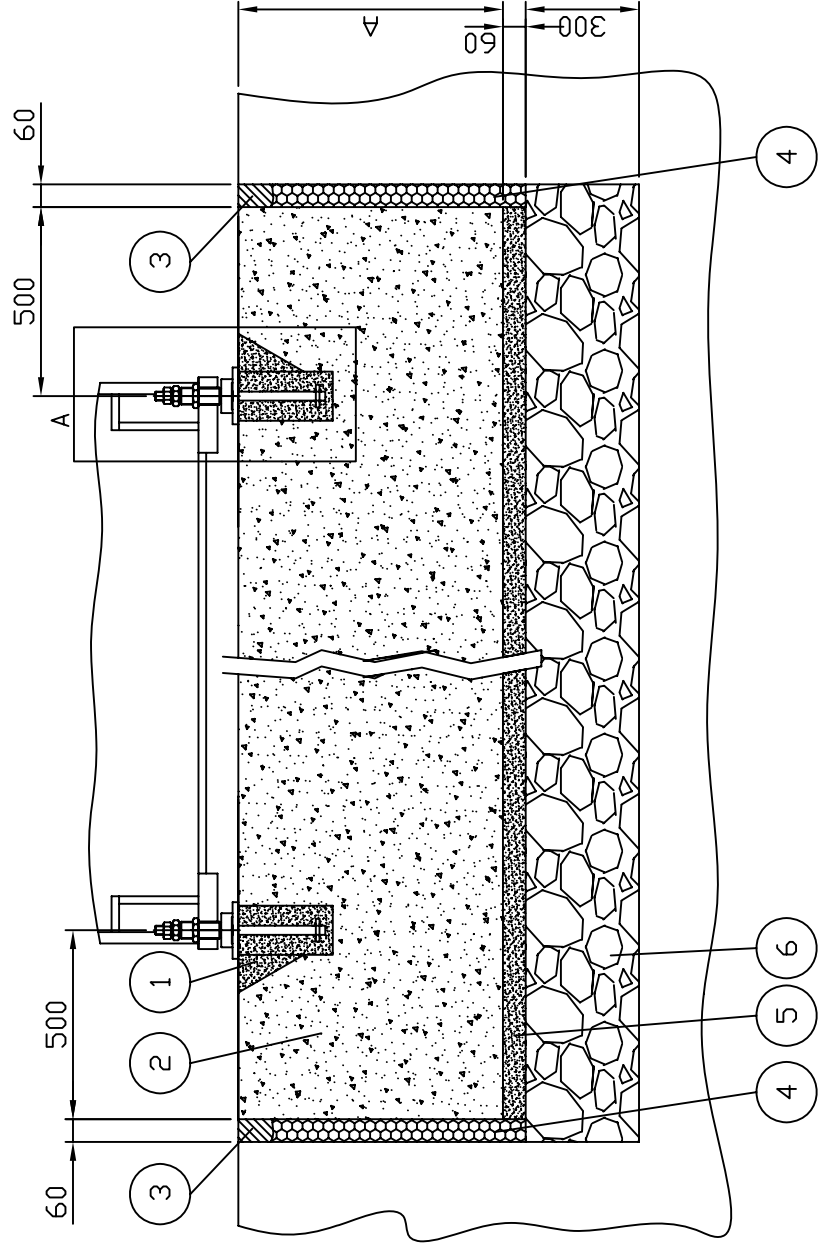

- 1> Concrete 5000pci
- 2> concrete 3000pci
- 3> Anti-oil/heat branze
- 4> Anti-vibration polyfoam
- 5> Anti-vibration sand
- 6> Round-shaps ston Dia 150~300

Leaderway Machinery Co. Ltd.

Scale	1:20		Drawing Name	PROCESS OF SETTING (地基施工圖)		Page	1/2	A4
	Drawn	jack	Date	96.11.20	Draw No.	8150198B0 (全機型)		
	Control	jack	Date	96.11.20				

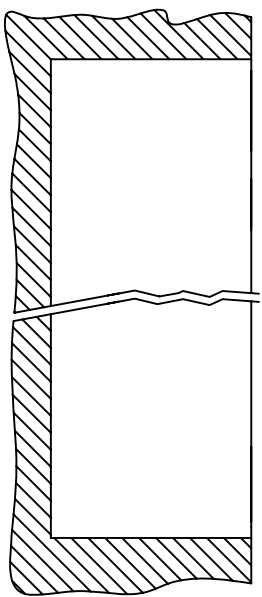

According to foundation drawing set the foundation area

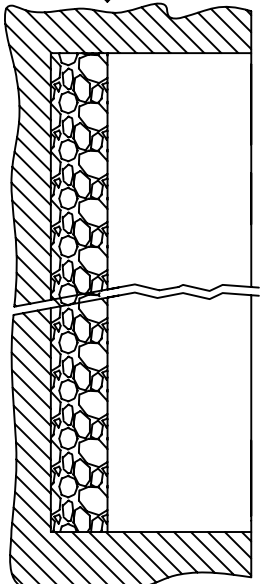

First, put stones on the bottom
stone dia 10mm~300mm

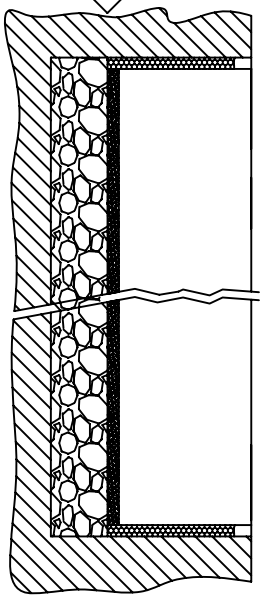

Fill up the sand and styrofoam plate on the other side

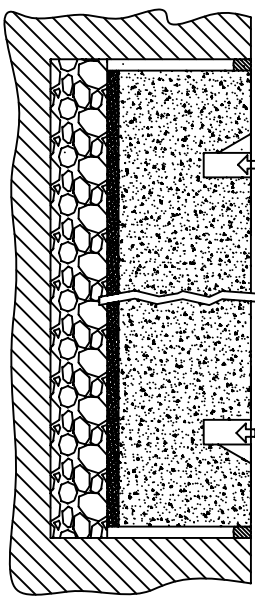

hoist machine higher and install the anchor bolts

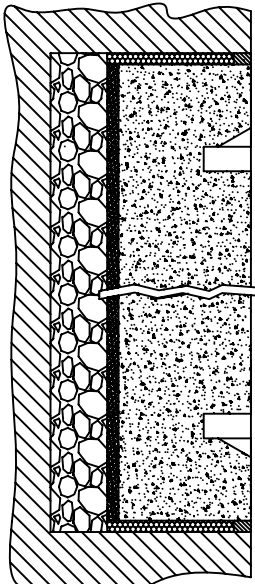

Dig out the hole of anchor bolts

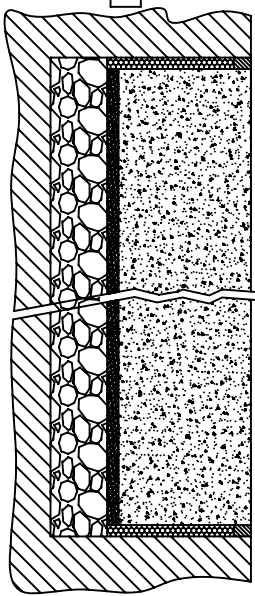

Put the oil-proof and anti-heat stripe on the other side, then fill up the cement(3000pci)
Harden time about 7~10 days

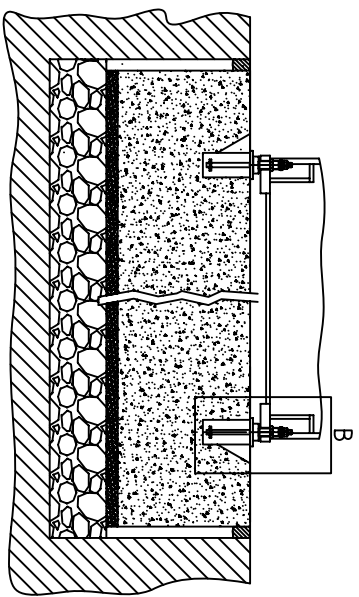

Put whole machine into the position

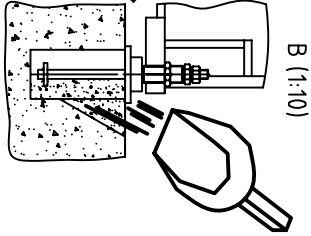

Fill up with 5000pci cement
harden time about 3~5 days

Leaderway Machinery Co. Ltd.

Scale
1:20

Drawing Name
PROCESS OF SETTING (地基施工圖)

Page
2/2
A4

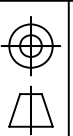

Drawn	Name	jack	Date	96.11.20
Control	Name	jack	Date	96.11.20

Draw No.
8150198B0 (全機型)

吊車 (CRANE)

10 TONS 吊車(CRANE)

10 TONS 吊車(CRANE)

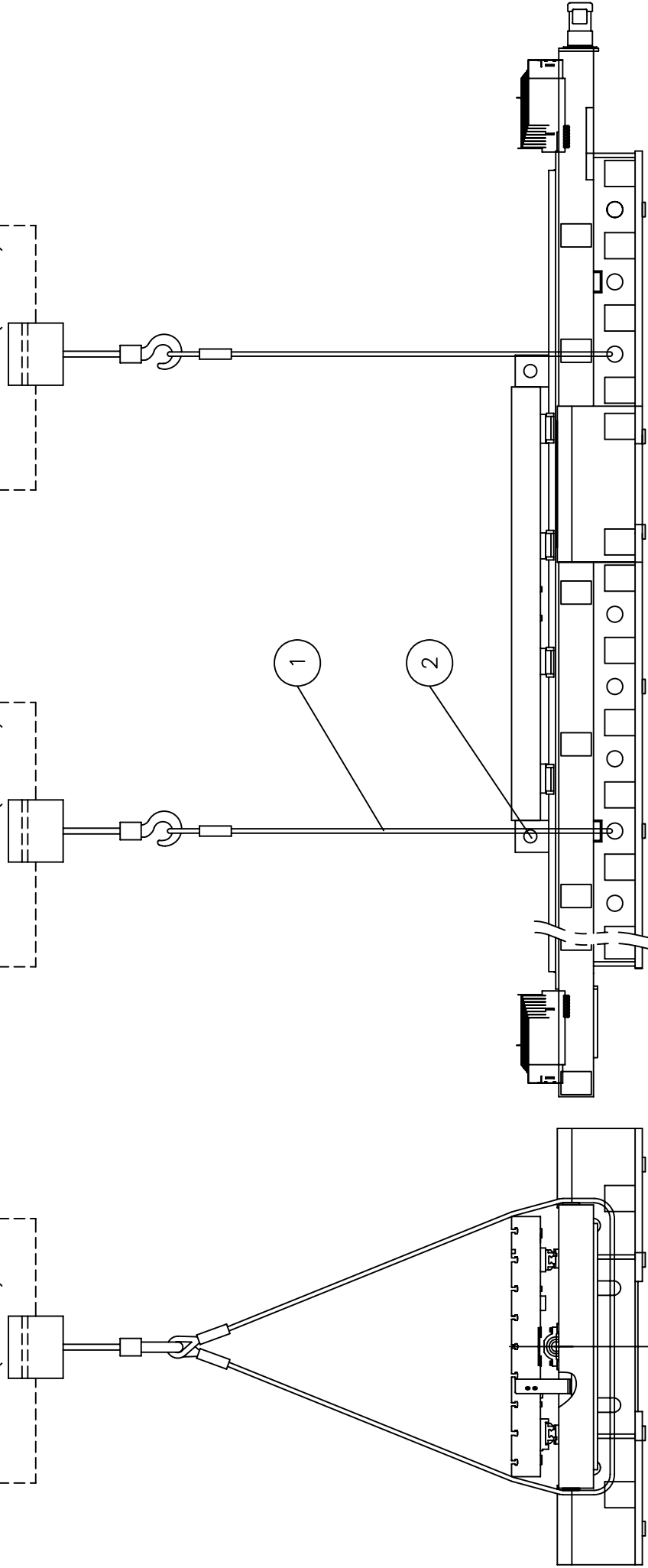

①

鋼線(Steel Wire)

數量(Q'TY): 2R(PCS)

1-1/4"

8000

②

出貨固定座(SHIPPING BRACKET)

數量(Q'TY): 2R(PCS)

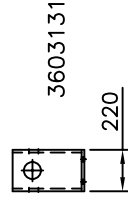
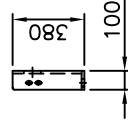

3603131

Leaderway Machinery Co. Ltd.

Scale 1:40	Drawing Name TRANSPORTATION DRAWING (吊架圖)	Page 3/3
	Drawn Control	Date 97.03.17
	Name AMY	Draw No. 8150191B0 (LX 大型龍門)

A4

97.03.17

97.03.17

20 TONS 吊車 (CRANE)

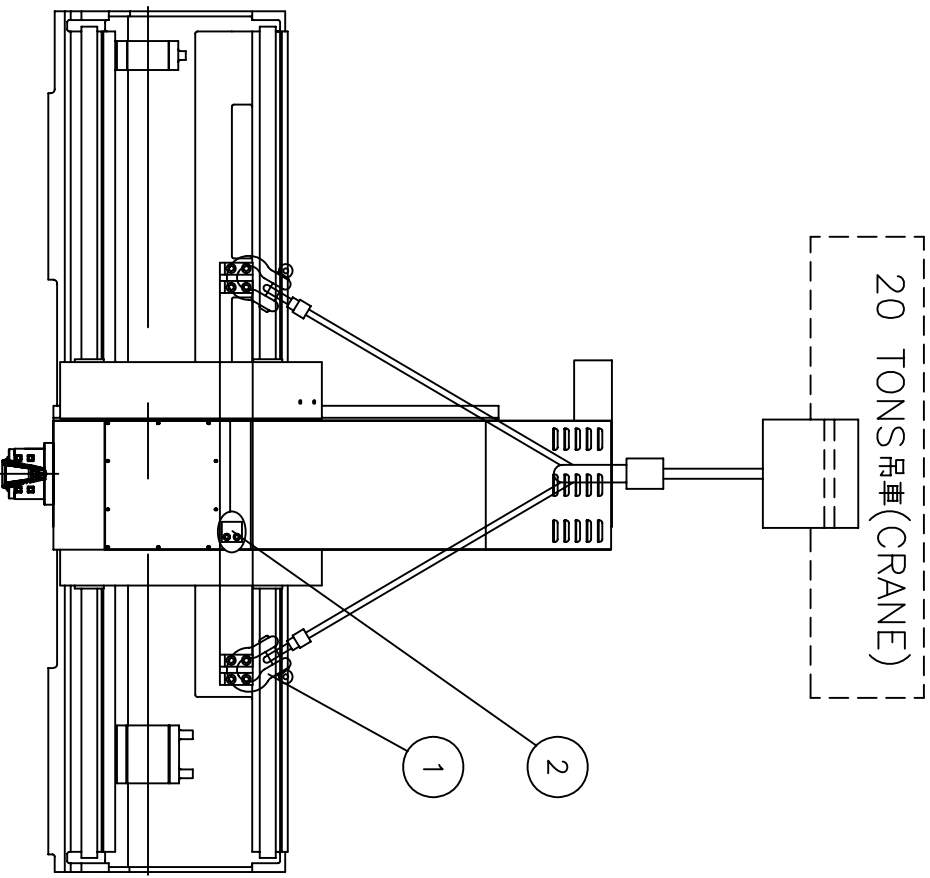

1 吊環組 (Hanging Set)
數量 (Q'TY): 4 組 (SET)

2 出貨固定座 (SHIPPING BRACKET)
數量 (Q'TY): 1 只 (PCS)

4 鋼繩 (Hanging Ring)
數量 (Q'TY): 1 只 (PCS)

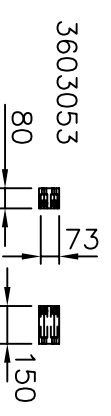

吊車 (CRANE)

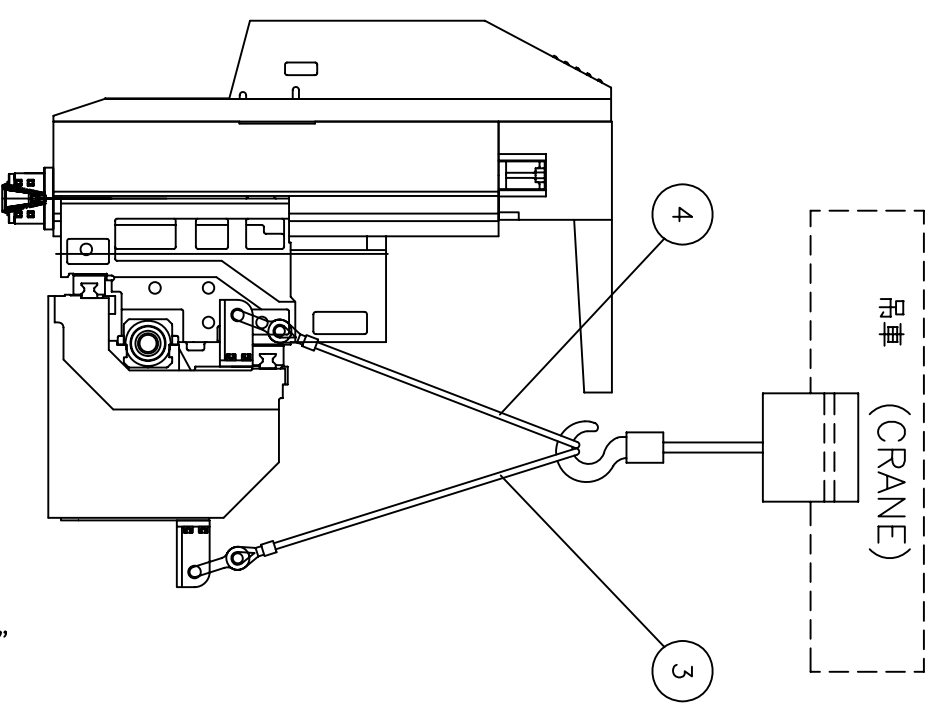

3 鋼繩 (Hanging Ring) 數量 (Q'TY): 1 只 (PCS)

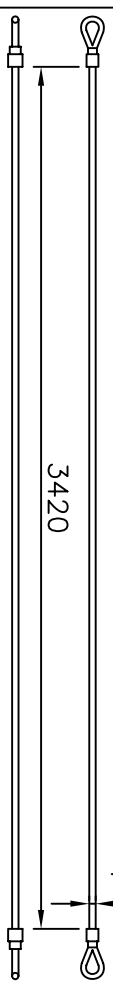
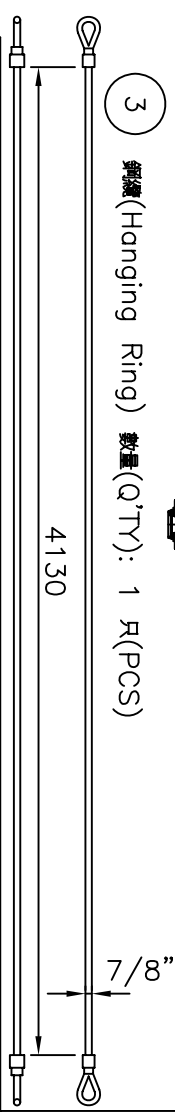

Leaderway Machinery Co. Ltd.

Scale 1:30
Drawing Name TRANSPORTATION DRAWING (吊架圖)

Page 1/3
A4

Drawn	Name	Date	Draw No.
Control	AMY	97.03.17	8150191B0 (LX 大型龍門)

10 TONS 吊車 (CRANE)

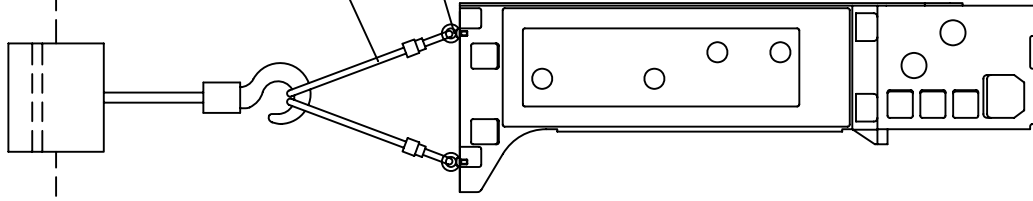

1 吊環 (Hanging Ring)
數量 (Q'TY): 4 只 (PCS)

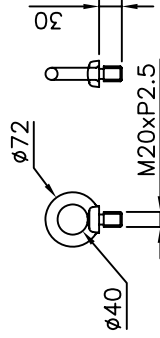

2 鋼繩 (Hanging Ring)
數量 (Q'TY): 2 只 (PCS)



吊車 (CRANE)

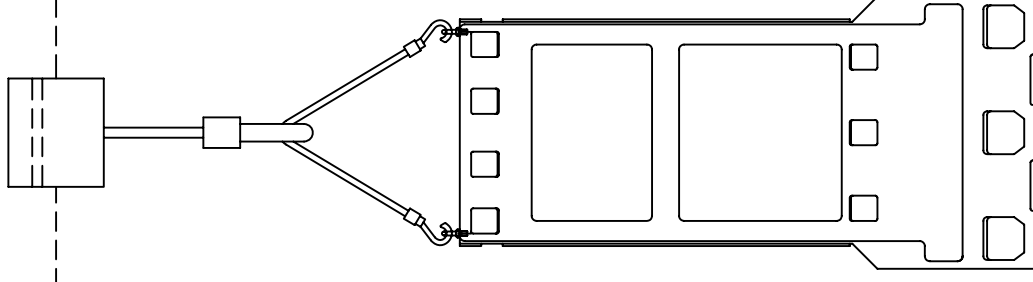

Leaderway Machinery Co. Ltd.

Scale
1:30

Drawing Name

TRANSPORTATION DRAWING (吊架圖)

Page
2/3

A4



Drawn Name AMY
Control AMY

Draw No.

8150191B0 (LX 大型龍門)

Date 97.03.17

97.03.17

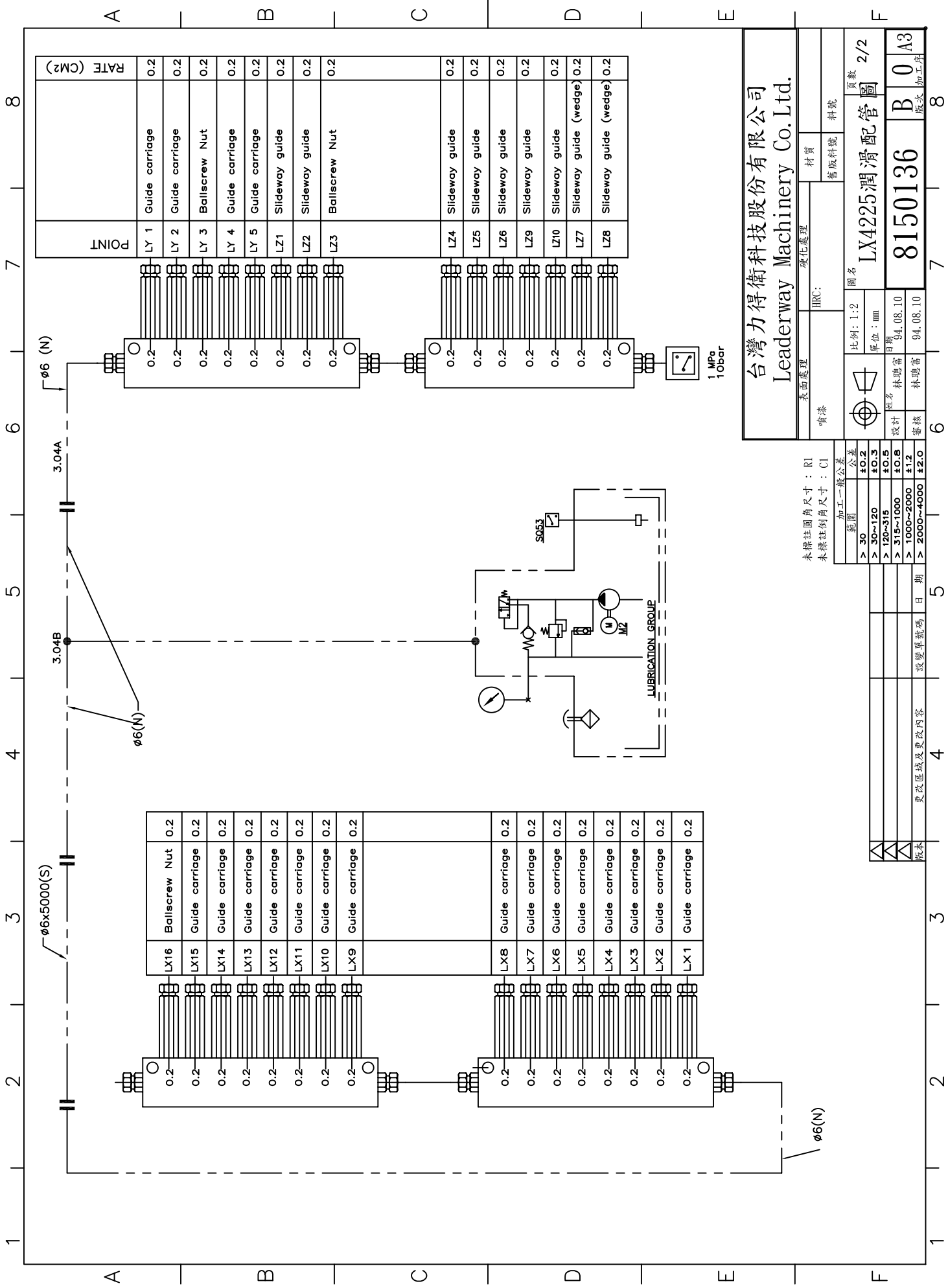

台灣力得衛科技股份有限公司
Leaderway Machinery Co. Ltd.

表面處理	硬化處理	噴漆	HRCC
材料	舊版料號	料號	
圖名	比例: 1:2	單位: mm	頁數 2/2
日期	94.08.10	設計	林聰富
審核	94.08.10	審核	林聰富
圖號		LX4225潤滑配管圖	
版本		B 0 A3	
變更單號碼		版次 加工序	

未標註圓角尺寸: R1
未標註倒角尺寸: C1

加工一般公差	公差
> 30	±0.2
> 30~120	±0.3
> 120~315	±0.5
> 315~1000	±0.8
> 1000~2000	±1.2
> 2000~4000	±2.0

更改區域及更改內容	日期
版本	

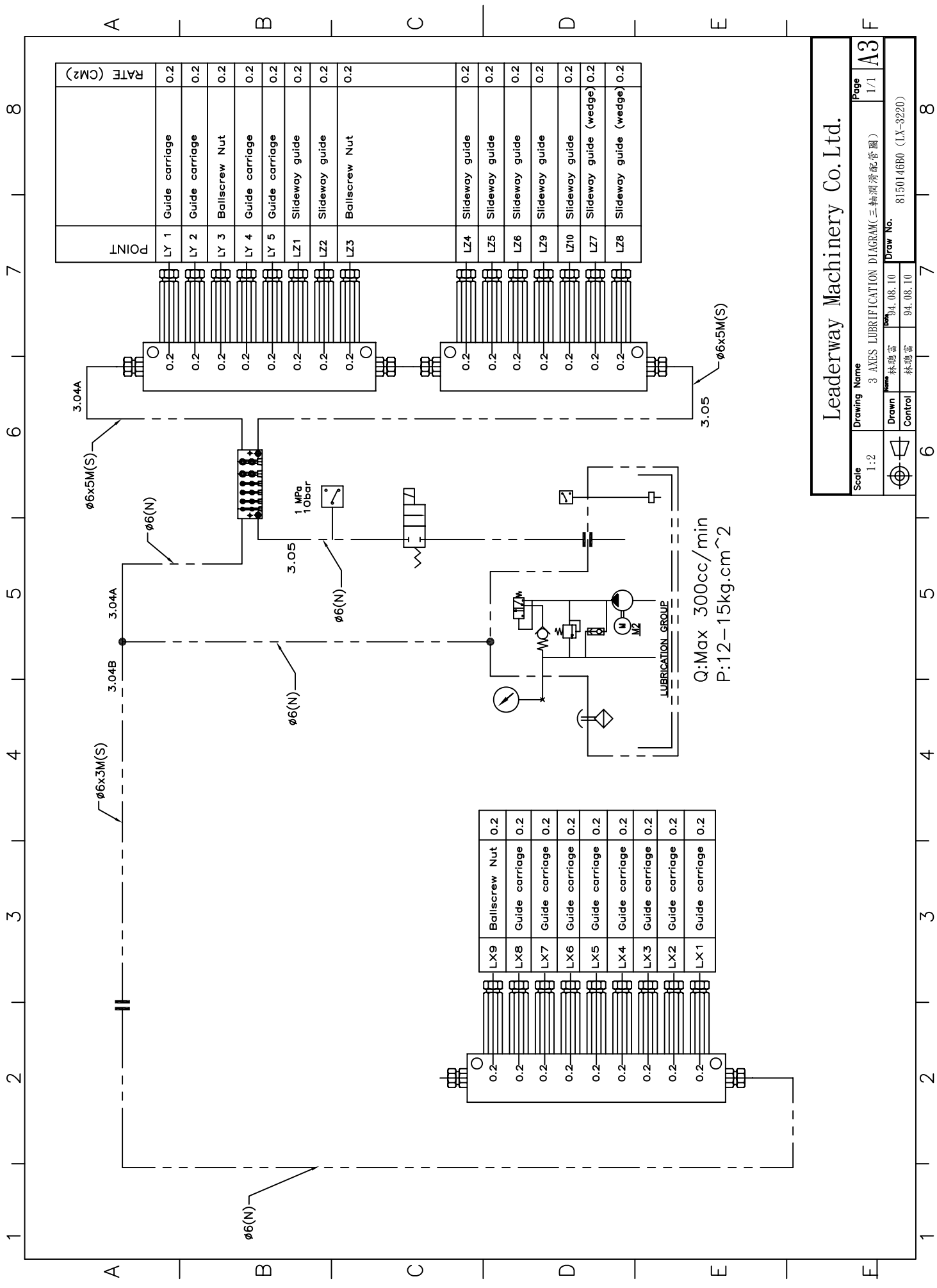

POINT	COMPONENT	RATE (CM ²)
LY 1	Guide carriage	0.2
LY 2	Guide carriage	0.2
LY 3	Ballscrew Nut	0.2
LY 4	Guide carriage	0.2
LY 5	Guide carriage	0.2
LZ1	Slideway guide	0.2
LZ2	Slideway guide	0.2
LZ3	Ballscrew Nut	0.2
LZ4	Slideway guide	0.2
LZ5	Slideway guide	0.2
LZ6	Slideway guide	0.2
LZ9	Slideway guide	0.2
LZ10	Slideway guide	0.2
LZ7	Slideway guide (wedge)	0.2
LZ8	Slideway guide (wedge)	0.2

LX9	Ballscrew Nut	0.2
LX8	Guide carriage	0.2
LX7	Guide carriage	0.2
LX6	Guide carriage	0.2
LX5	Guide carriage	0.2
LX4	Guide carriage	0.2
LX3	Guide carriage	0.2
LX2	Guide carriage	0.2
LX1	Guide carriage	0.2

Q: Max 300cc/min
P: 12-15kg.cm²

Leaderway Machinery Co. Ltd.

Scale	1:2
Drawing Name	3 AXES LUBRIFICATION DIAGRAM(三軸潤滑配管圖)
Page	1/1
Drawn	林聰雷 94.08.10
Control	林聰雷 94.08.10
Draw No.	815014680 (LX-3220)

F

1 2 3 4 5 6 7 8

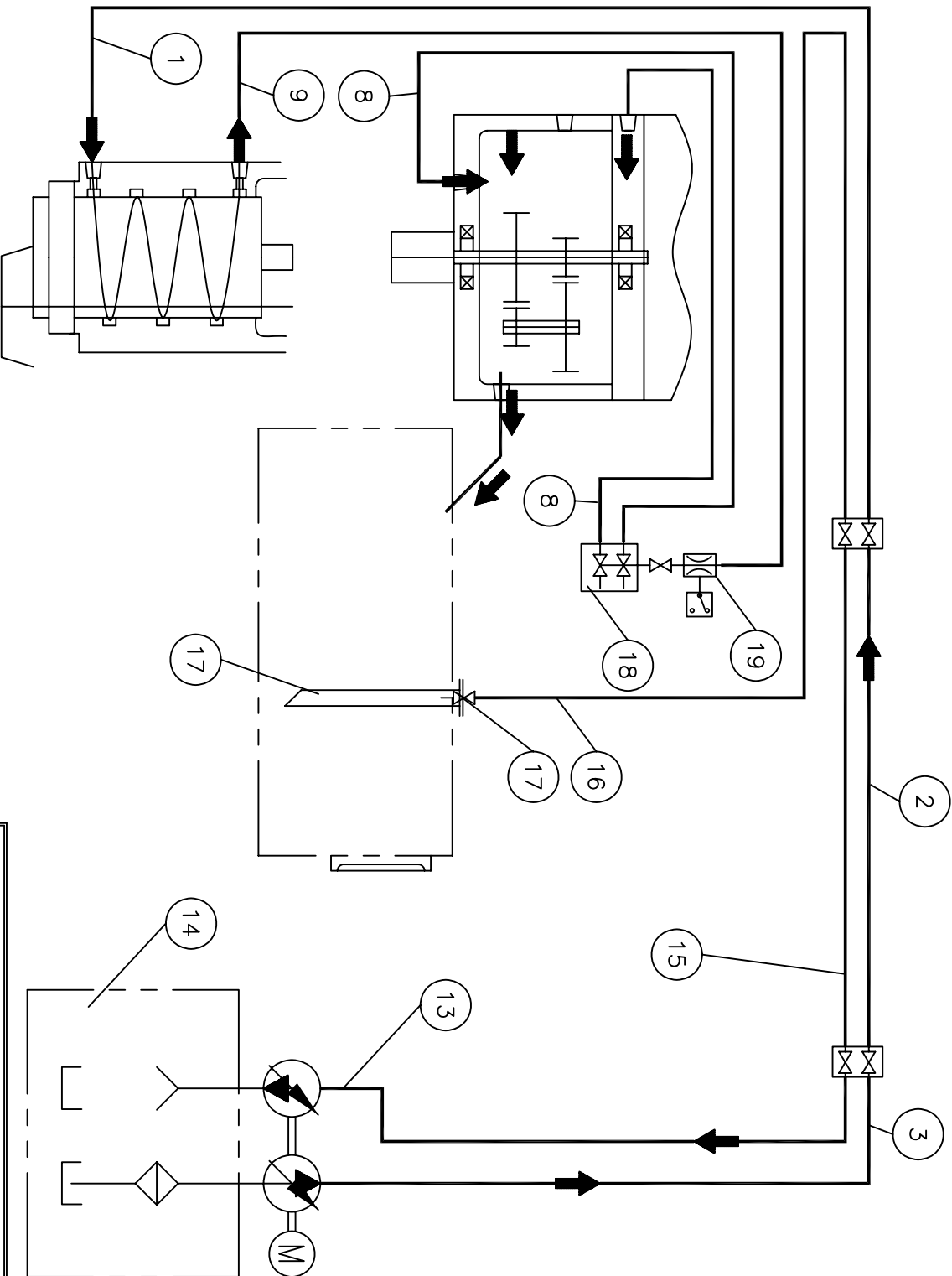

- (1) 1/4"PH-5700L-高壓油管
- (2) 1/4"PH-5700L-高壓油管
- (3) 1/4"PH-5000L-高壓油管
- (4) 1/4"PH-5000L-高壓油管
- (5) 油冷卻機(4000 BTU/Hr)
- (6) 1/4"PH-5700L-高壓油管
- (7) 1/4"PH-5200L-高壓油管
- (8) $\phi 6$ -透明 PU管 x2
- (9) 1/4"PH-1700L-高壓油管
- (10) 定積脫壓給油泵
- (11) 浮動開關接棒
- (12) 冷排(浸油式)
- (13) 1/2"PH-5000L-高壓油管
- (14) 油冷卻機(12,000 BTU/Hr)
- (15) 1/2"PH-5700L-高壓油管
- (16) 1/2"PH-5700L-高壓油管
- (17) 4160534270x1-立卜管
- (18) 3520000A0x1-接水座
- (19) 4802411506x1-流量開關組

Leaderway Machinery Co. Ltd.

Scale 1:2		Drawing Name GEAR BOX LUBRIFICATION DIAGRAM(齒輪箱潤滑配管圖)		Page 1/1	
Drawn 林聰富	Date 94.08.29	Draw No. 8150139D0 (LX-B)		A4	
Control 林聰富	Date 94.08.29				

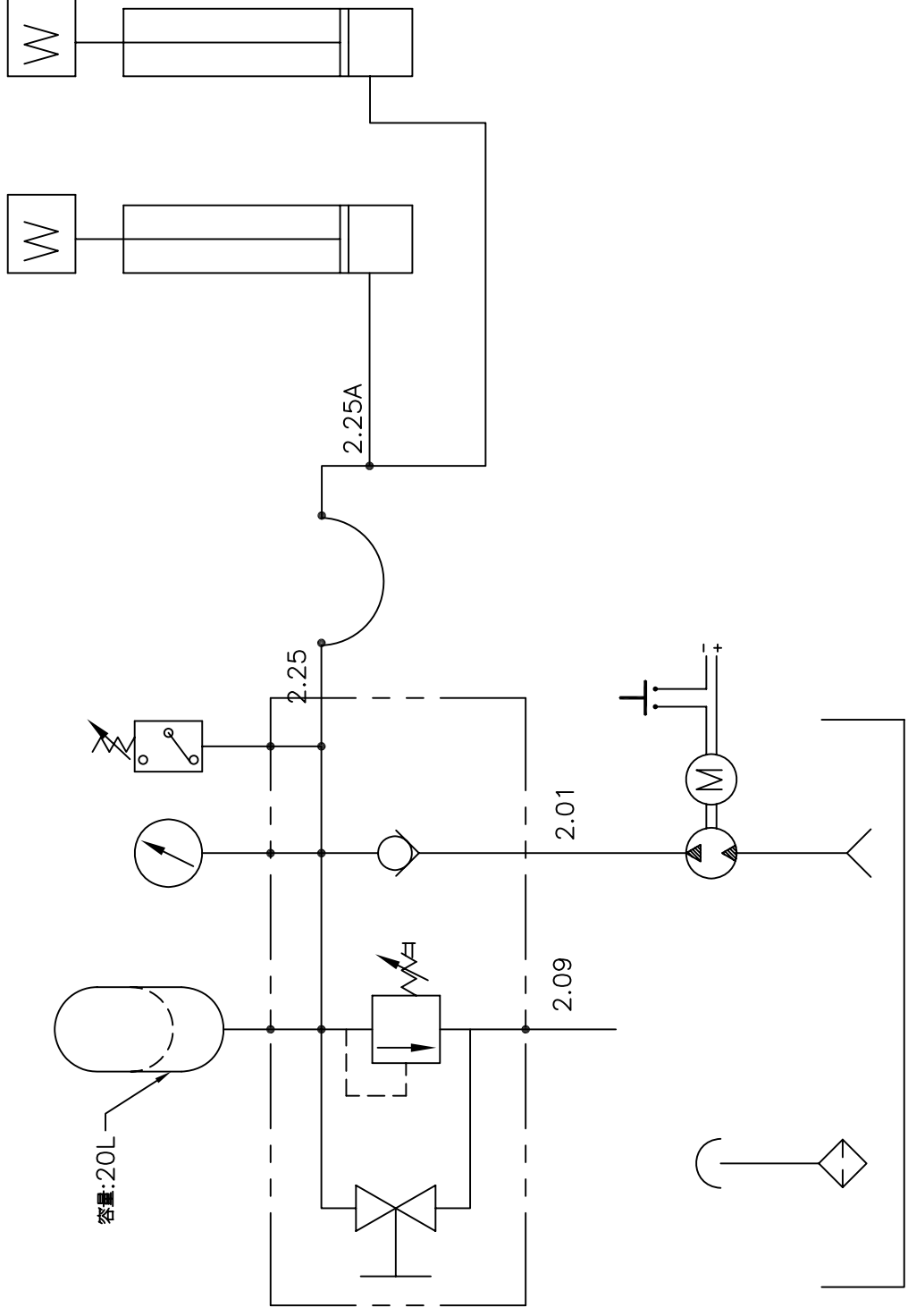

容量:20L

Leaderway Machinery Co. Ltd.

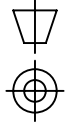
Scale	Drawing Name		Page
1:4	COUNTER BALANCE UNIT (平衡配重系統)		1/1
	Drawn	Date	Draw No.
	Control	2007.11.08	

A4

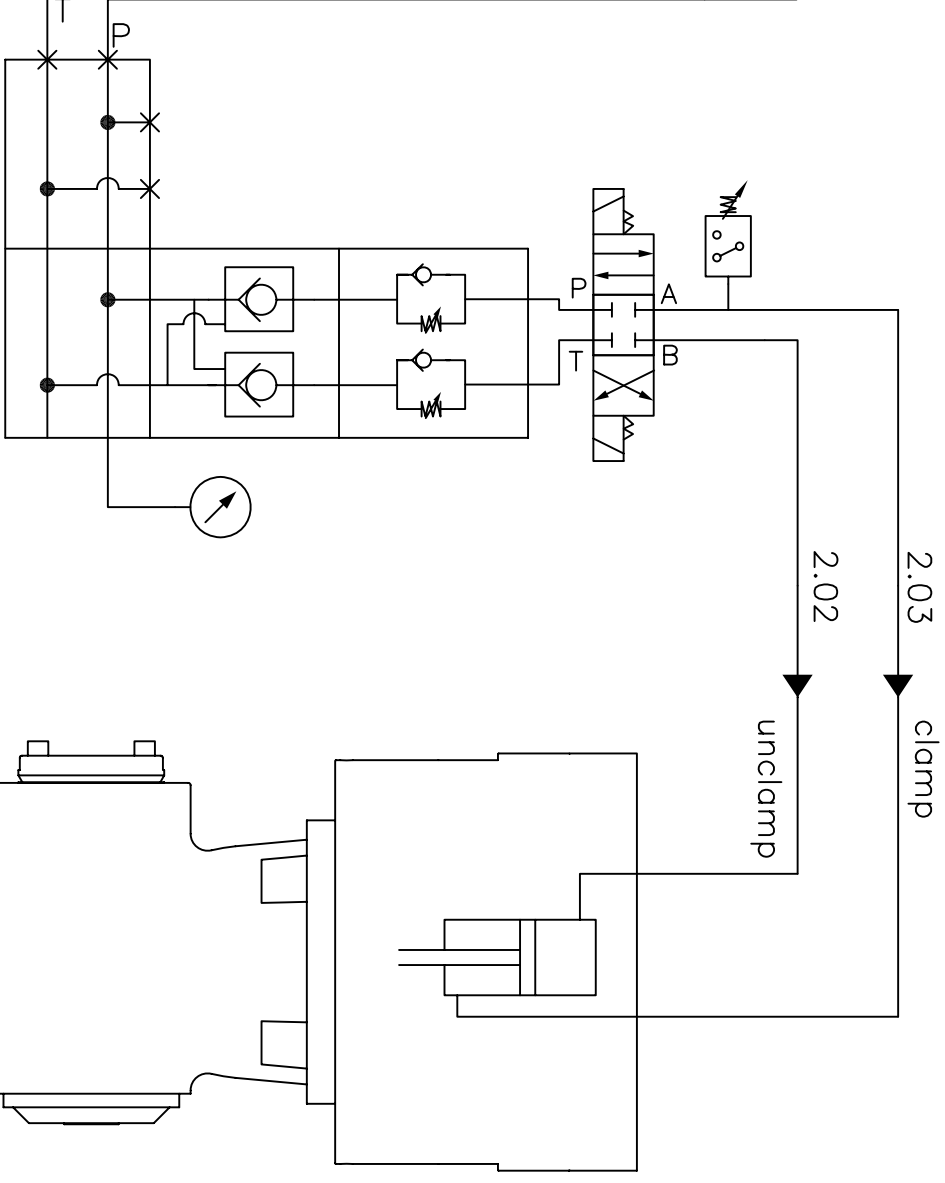
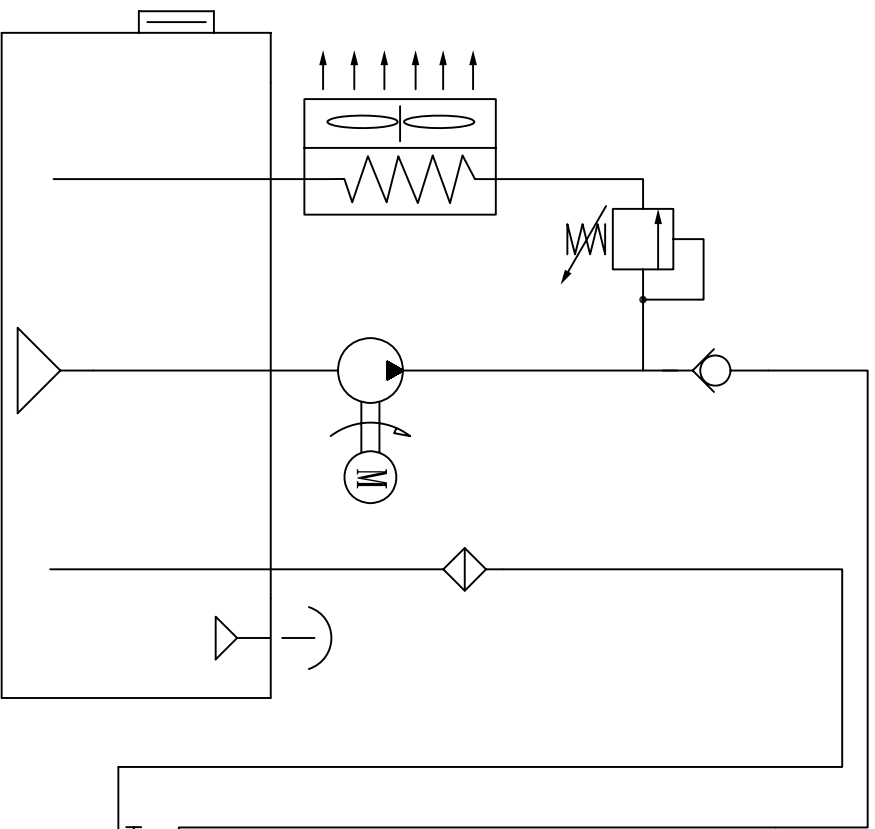

Leaderway Machinery Co. Ltd.

Scale

1:1

Drawing Name

ANGULAR MILL HEAD HYDRAULIC DIAGRAM(臥頭迴路圖)

Page

1/1

A4

Drawn

卜楓云

Date

97.12.08

Draw No.

8150241A0 (LX-B)

Control

審核者

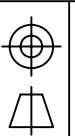

1 2 3 4 5 6 7 8

A

B

C

D

E

F

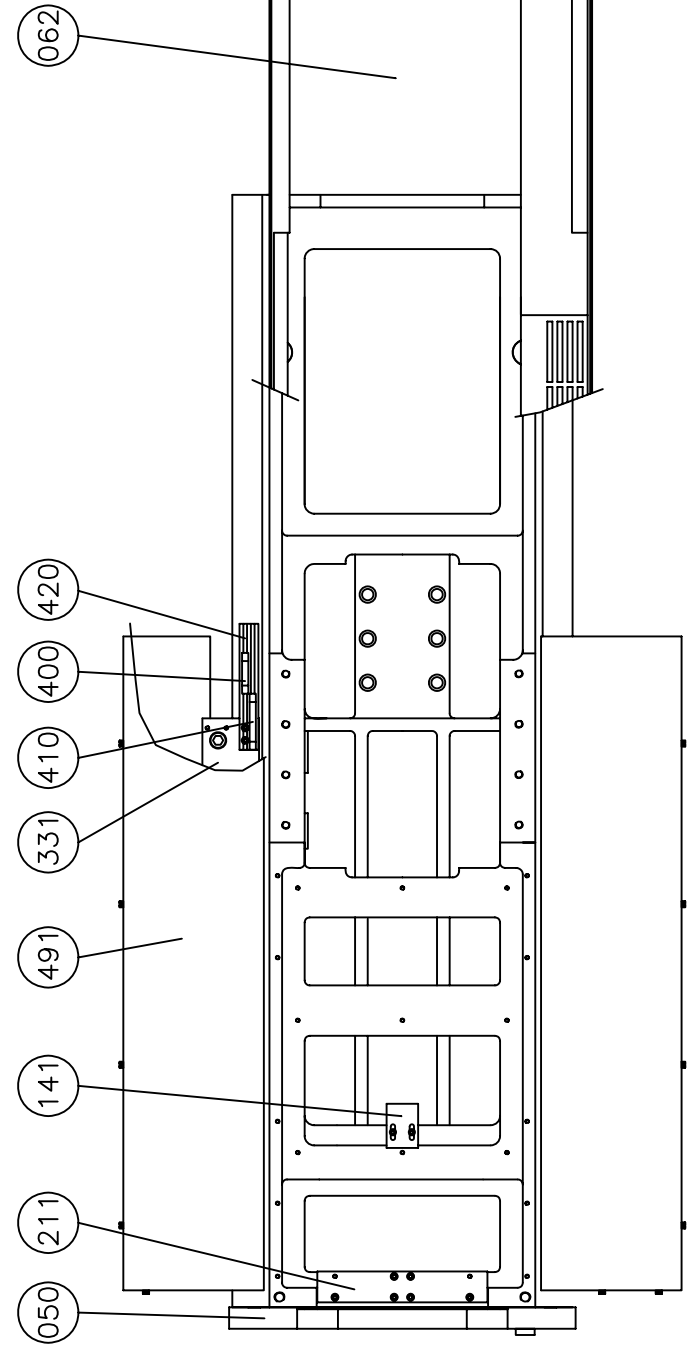
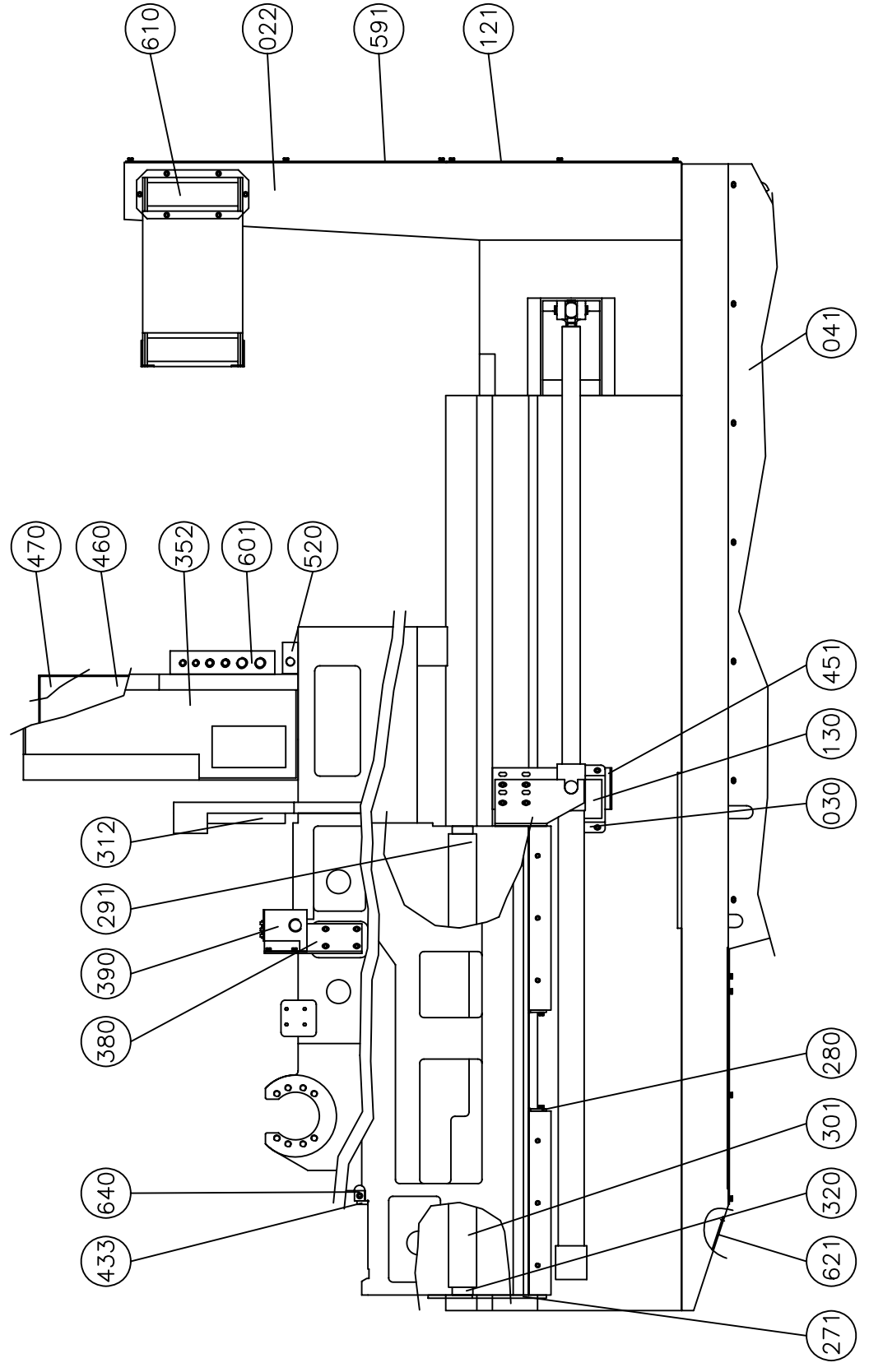

Leaderway Machinery Co. Ltd.

Scale	1:12	Drawing Name	SADDLE+SPINDLE HEAD UNIT (主軸頭+鞍座單元 Z=800皮帶問傳)	Page	1/1
		Drawn	陳慶仁	Draw No.	8120351C0 (2F11019)
		Control	審核	Date	97.03.12
				yy. mm. dd	

1 2 3 4 5 6 7 8

*單階材料用量清單

製表日期: 102-12-10

第1頁

主件品號	序號	元件品號	品名 英文品名	規 格	用 量
2F11019			主軸頭+鞍座單元 SPINDLE HEAD + SADDLE UNIT	LX-B\#50(Z=800皮帶間傳)	
	0012	3603043D0	主軸頭 SPINDLE HEAD	1010\FCD-60\3603043B2	1
	0022	3603003E0	連動管座 CONDUIT BRACKET	7210\SPCC	1
	0030	3603004A0	微動開關座 SWITCH BRACKET	7160\SPCC	1
	0041	3603241B0	前罩蓋板 FRONT COVER	7510\請改下3603241C0	1
	0050	3603242A0	下承油座 LOWER OIL COLLECTING BRACKET	7210\SPCCZ	1
	0062	3603240C0	機頭前蓋板座 FRONT COVER BRACKET	7510\請改3603240D0	1
	0070	3603011A0	蓋板 COVER	7180\SPCC	1
	0090	3603013B0	蓋板 COVER	7180\SPCC	1
	0121	3603016C0	上配線槽蓋 ELECTRICAL CONDUIT COVER	7540\SPCC	1
	0130	4800120261	微動開關(2聯滾珠型) MICRO SWITCH	BNS819-B02-L12-61-12-10	1
	0141	3603023D0	近接開關座 PROXIMITY SWITCH BRACKET	7160\SPCC	1
	0150	4210138010	噴水管 NOZZLE TUBE	3/8"轉接頭*軟管x15*3/8"噴嘴	2
	0160	4250103838	球閥內外牙(考克) BALL VALVE	3/8	2
	0170	4250101414	球閥內外牙 BALL VALVE	1/4"	2
	0180	4210114016	噴水管 NOZZLE TUBE	1/4"轉接頭*軟管x16*1/4"噴嘴	2
	0190	4801301201	開關固定座 SWITCH BRACKET	BES 12.0-BS-1	1
	0211	3603243B0	分流座 OIL DISTRIBUTOR BRACKET	4150\AL	1
	0220	4060010010	O型環 O RING	P-10	2
	0240	3603042B0	鞍座 SADDLE	1040\FC-30\3603042A2\LX4225	1
	0251	3603046B0	刮油板(一)左上 WIPER (1)	4380\鋁板	1

<續下頁>

*單階材料用量清單

製表日期: 102-12-10

第2頁

主件品號	序號	元件品號	品名 英文品名	規 格	用 量
2F11019	0261	3603047B0	刮油板(二)右上 WIPER (2)	4380\鋁板	1
	0271	3603048B0	刮油板(三)下 WIPER (3)	4380\鋁板	1
	0280	3603049A0	刮油板(中) WIPER	4380\鋁板	4
	0290	3603050A0	斜銷(上) SLIDING PIN(UPPER)	1100\請改下3603050B0	1
	0300	3603051A0	斜銷(下) SLIDING PIN(LOWER)	1100\請改下3603051B0	1
	0311	3603052B0	上護板 UPPER PLATE	7510\請改下3603052C0	1
	0320	3170145A0	斜楔調整板 ADJUSTING WEDGE PAD	3200\SS41	2
	0330	3603054B0	壓板 LOCKING PLATE	3120\SS45C	4
	0341	3603055C0	側飾板(鞍座) SADDLE SIDE COVER	7510\SPCC	1
	0352	3603056D0	連結板(連動管) CONNECTING PLATE	7210\SPCC	1
	0360	3603057A0	斜銷檔板 SLIDING PIN PAD	3100\SS41	2
	0380	3170413A0	微動開關固定座 SWITCH BRACKET	7160\SPCC	1
	0390	4800140310	微動開關(3聯滾珠型) MICRO SWITCH	BNS819-D03-L12-100-10	1
	0400	3540007A0	碰塊 DOG	4140\AL 外購65L	2
	0410	3540005A0	碰塊 DOG	3140\SS41 外購89長	1
	0420	3580048A0	碰塊座 DOG BRACKET	4140\AL(200m/m*2軌)	2
	0431	3170514B0	滑塊側面墊片 SLIDING BLOCK PAD	3180\請改下3170514C0	2
	0440	3170521A0	檔塊 STOPPER	3140\SS41	2
	0461	3603218B0	電氣盒 TERMINAL BOX	7210\請改下3603218C0	1
	0470	3540114C0	電氣盒蓋 TERMINAL BOX COVER	7210\SPCC	1
	0491	3603231B0	鞍座側飾板(左) SADDLE SIDE COVER(L)	7510\SPCC\LX-B	1

<續下頁>

*單階材料用量清單

製表日期: 102-12-10

第3頁

主件品號	序號	元件品號	品名 英文品名	規 格	用 量
2F11019	0591	3603310C0	上配線槽蓋(二) ELECTRICAL CONDUIT COVER(2)	7210\SPCC	1
	0601	3603380B0	分油座 OIL DISTRIBUTOR BRACKET	3150\請改下3603380C0	1
	0610	4640065350	方型聯動管 WIRE CONDUIT	KY-EC(CBS65.3)-45x175-365-5	1
	0621	3603468B0	蓋板 COVER	7180\SPCC	1
	0630	3603509A0	機頭側罩 SIDE COVER	7510\SPCC	1
	0640	3560129A0	斜楔T-3 WEDGE	9280\粉末冶金	4

<結 束>

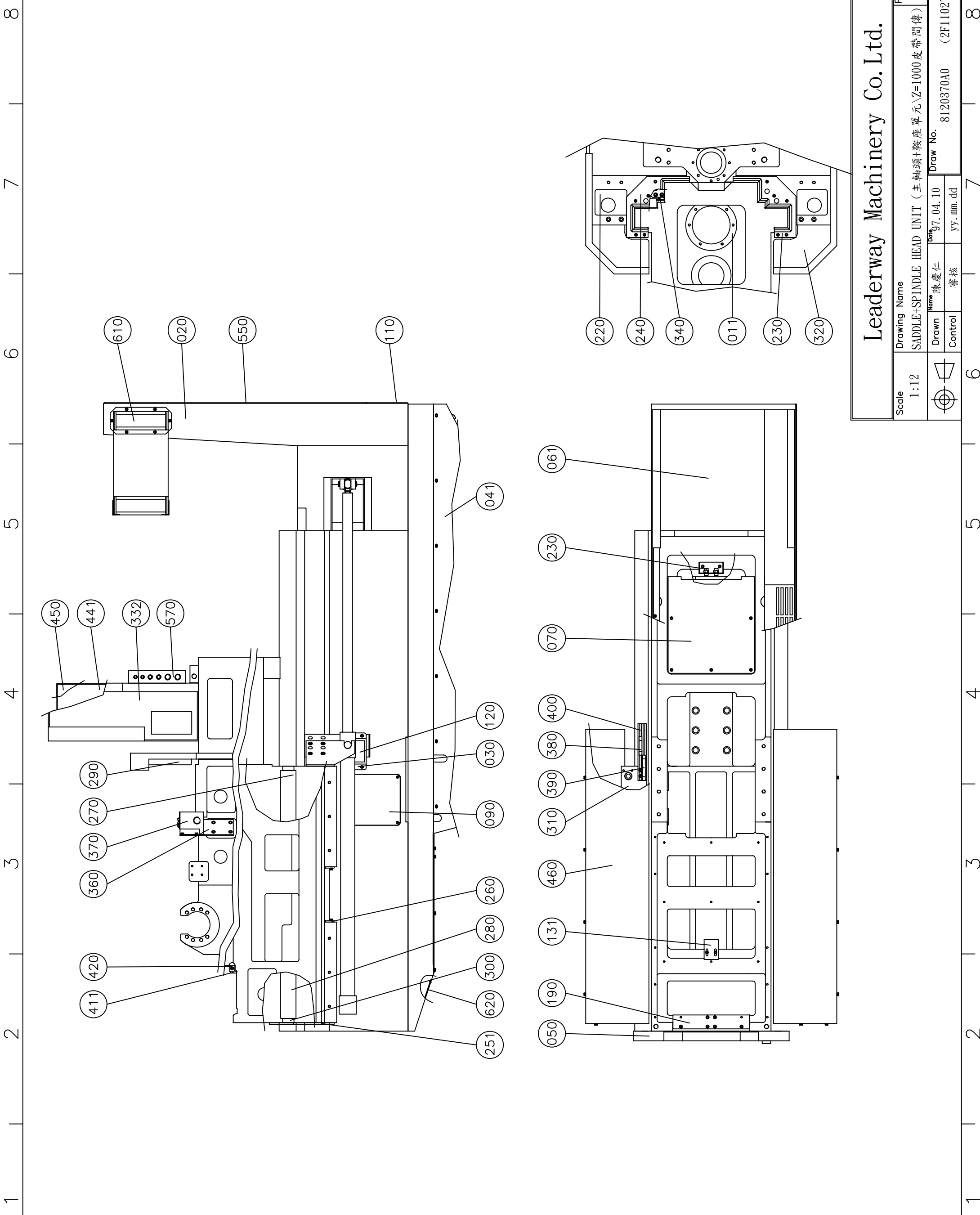

A

B

C

D

E

F

8

7

6

5

4

3

2

1

A

B

C

D

E

F

8

7

6

5

4

3

2

1

610

020

550

110

450

441

332

570

290

270

370

360

420

411

041

120

030

090

260

280

300

620

251

061

230

070

400

380

390

310

460

131

190

050

220

240

340

011

230

320

Leaderway Machinery Co. Ltd.

Scale
1:12

Drawing Name
SADDLE+SPINDLE HEAD UNIT (主軸頭+鞍座單元\Z=1000皮帶問傳)

Page
1/1

A3

Drawn
陳慶仁

Date
97.04.10

Control
審核

Draw No.
8120370A0

(2F11027)

*單階材料用量清單

製表日期: 102-01-03

第1頁

主件品號	序號	元件品號	品名 英文品名	規 格	用 量
2F11027			主軸頭+鞍座單元 SPINDLE HEAD + SADDLE UNIT	LX-B\#50(Z=1000皮帶間傳)	
	0011	3603309B0	主軸頭 SPINDLE HEAD	1010\FCD-60\3603309A2	1
	0022	3603334C0	連動管座 CONDUIT BRACKET	7210\SPCC	1
	0030	3603004A0	微動開關座 SWITCH BRACKET	7160\SPCC	1
	0042	3603335C0	前罩蓋板 FRONT COVER	7510\SPCC	1
	0050	3603242A0	下承油座 LOWER OIL COLLECTING BRACKET	7210\SPCCZ	1
	0062	3603336C0	前罩蓋板座 FRONT COVER BRACKET	7510\SPCC	1
	0070	3603011A0	蓋板 COVER	7180\SPCC	1
	0080	3603012B0	蓋板 COVER	7180\SPCC	1
	0090	3603013B0	蓋板 COVER	7180\SPCC	1
	0100	3603015C0	前內蓋板 FRONT INNER COVER	7510\SPCC	1
	0110	3603337A0	連動管座蓋板(一) CONDUIT BRACKET CAP(1)	7180\SPCC	1
	0120	4800120261	微動開關(2聯滾珠型) MICRO SWITCH	BNS819-B02-L12-61-12-10	1
	0131	3603023D0	近接開關座 PROXIMITY SWITCH BRACKET	7160\SPCC	1
	0140	4210138010	噴水管 NOZZLE TUBE	3/8"轉接頭*軟管x15*3/8"噴嘴	2
	0150	4250103838	球閥內外牙(考克) BALL VALVE	3/8	2
	0160	4250101414	球閥內外牙 BALL VALVE	1/4"	2
	0170	4210114016	噴水管 NOZZLE TUBE	1/4"轉接頭*軟管x16*1/4"噴嘴	2
	0180	4801301201	開關固定座 SWITCH BRACKET	BES 12.0-BS-1	1
	0190	3603243B0	分流座 OIL DISTRIBUTOR BRACKET	4150\AL	1
	0200	4060010010	O型環 O RING	P-10	2

<續下頁>

*單階材料用量清單

製表日期: 102-01-03

第2頁

主件品號	序號	元件品號	品名 英文品名	規 格	用 量
2F11027	0220	3603308A0	鞍座 SADDLE	1040\FC-30\3603308A2\LX-B	1
	0230	3603046B0	刮油板(一)左上 WIPER (1)	4380\鋁板	1
	0240	3603047B0	刮油板(二)右上 WIPER (2)	4380\鋁板	1
	0251	3603048B0	刮油板(三)下 WIPER (3)	4380\鋁板	1
	0260	3603049A0	刮油板(中) WIPER	4380\鋁板	4
	0271	3603050B0	斜銷(上) SLIDING PIN(UPPER)	1100\FC-25\3603050A2	1
	0281	3603051B0	斜銷(下) SLIDING PIN(LOWER)	1100\FC-25\3603051A2	1
	0292	3603052C0	上護板 UPPER PLATE	7510\SPCC	1
	0300	3170145A0	斜楔調整板 ADJUSTING WEDGE PAD	3200\SS41	2
	0311	3603054C0	壓板 LOCKING PLATE	3120\S45C	4
	0321	3603055C0	側飾板(鞍座) SADDLE SIDE COVER	7510\SPCC	1
	0332	3603056D0	連結板(連動管) CONDUIT BRACKET	7210\SPCC	1
	0340	3603057A0	斜銷檔板 SLIDING PIN PAD	3100\SS41	2
	0350	4640065350	方型聯動管 WIRE CONDUIT	KY-EC(CBS65.3)-45x175-365-5	1
	0360	3170413A0	微動開關固定座 SWITCH BRACKET	7160\SPCC	1
	0370	4800140310	微動開關(3聯滾珠型) MICRO SWITCH	BNS819-D03-L12-100-10	1
	0380	3540007A0	碰塊 DOG	4140\AL 外購65L	2
	0390	3540005A0	碰塊 DOG	3140\SS41 外購89長	1
	0400	3580048A0	碰塊座 DOG BRACKET	4140\AL(200m/m*2軌)	1
	0413	3170514D0	滑塊側面墊片 SLIDING BLOCK PAD	3180\S45C	2
	0420	3170521A0	檔塊 STOPPER	3140\SS41	2

<續下頁>

*單階材料用量清單

製表日期: 102-01-03

第3頁

主件品號	序號	元件品號	品名 英文品名	規 格	用 量
2F11027	0442	3603218C0	電氣盒 TERMINAL BOX	7210\SPCC	1
	0450	3540114C0	電氣盒蓋 TERMINAL BOX COVER	7210\SPCC	1
	0461	3603231B0	鞍座側飾板(左) SADDLE SIDE COVER(L)	7510\SPCC\LX-B	1
	0540	3603340A0	碰塊座 DOG BRACKET	3140\SS41	1
	0550	3603341A0	連動管座蓋板(二) CONDUIT BRACKET CAP(2)	7180\SPCC	1
	0560	3603468B0	蓋板 COVER	7180\SPCC	1
	0571	3603380C0	分油座 OIL DISTRIBUTOR BRACKET	3150\SS41	1
	0580	3603509A0	機頭側罩 SIDE COVER	7510\SPCC	1
	0590	3560129A0	斜楔T-3 WEDGE	9280\粉末冶金	4

<結 束>

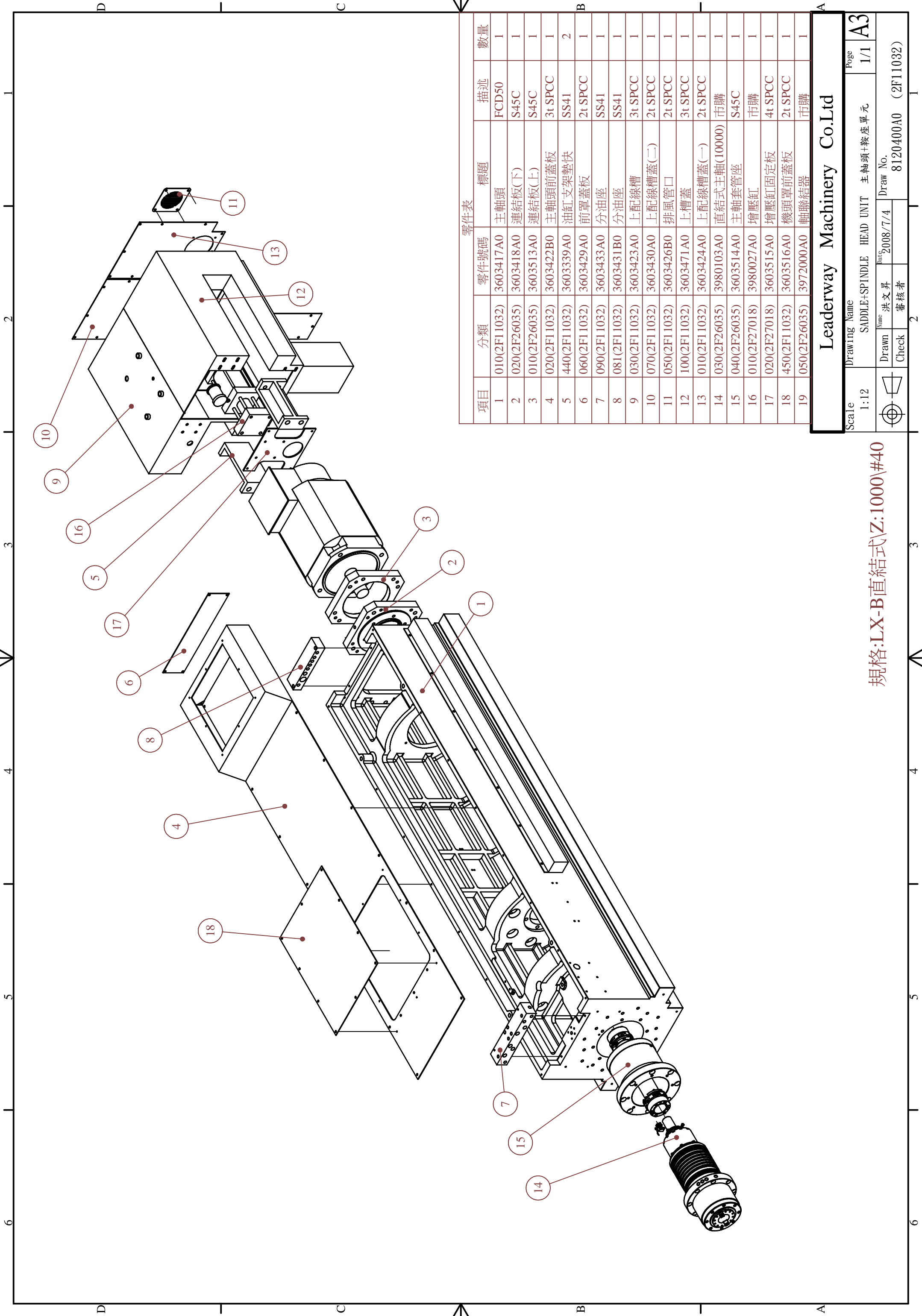

項目	分類	零件號碼	標題	描述	數量
1	010(2F11032)	3603417A0	主軸頭	FCD50	1
2	020(2F26035)	3603418A0	連結板(下)	S45C	1
3	010(2F26035)	3603513A0	連結板(上)	S45C	1
4	020(2F11032)	3603422B0	主軸頭前蓋板	3t SPCC	1
5	440(2F11032)	3603339A0	油缸支架墊快	SS41	2
6	060(2F11032)	3603429A0	前罩蓋板	2t SPCC	1
7	090(2F11032)	3603433A0	分油座	SS41	1
8	081(2F11032)	3603431B0	分油座	SS41	1
9	030(2F11032)	3603423A0	上配線槽	3t SPCC	1
10	070(2F11032)	3603430A0	上配線槽蓋(二)	2t SPCC	1
11	050(2F11032)	3603426B0	排風管口	2t SPCC	1
12	100(2F11032)	3603471A0	上槽蓋	3t SPCC	1
13	010(2F11032)	3603424A0	上配線槽蓋(一)	2t SPCC	1
14	030(2F26035)	3980103A0	直結式主軸(10000)	市購	1
15	040(2F26035)	3603514A0	主軸套管座	S45C	1
16	010(2F27018)	3980027A0	增壓缸	市購	1
17	020(2F27018)	3603515A0	增壓缸固定板	4t SPCC	1
18	450(2F11032)	3603516A0	機頭罩前蓋板	2t SPCC	1
19	050(2F26035)	3972000A0	軸聯結器	市購	1

Leaderway Machinery Co.Ltd

Scale 1:12	Drawing Name SADDLE+SPINDLE HEAD UNIT	Page 1/1
Drawn 洪文昇	HEAD UNIT 主軸頭+鞍座單元	Draw No. 2008/7/4
Check 審核者		8120400A0 (2F11032)

規格:LX-B直結式(Z:1000)#40

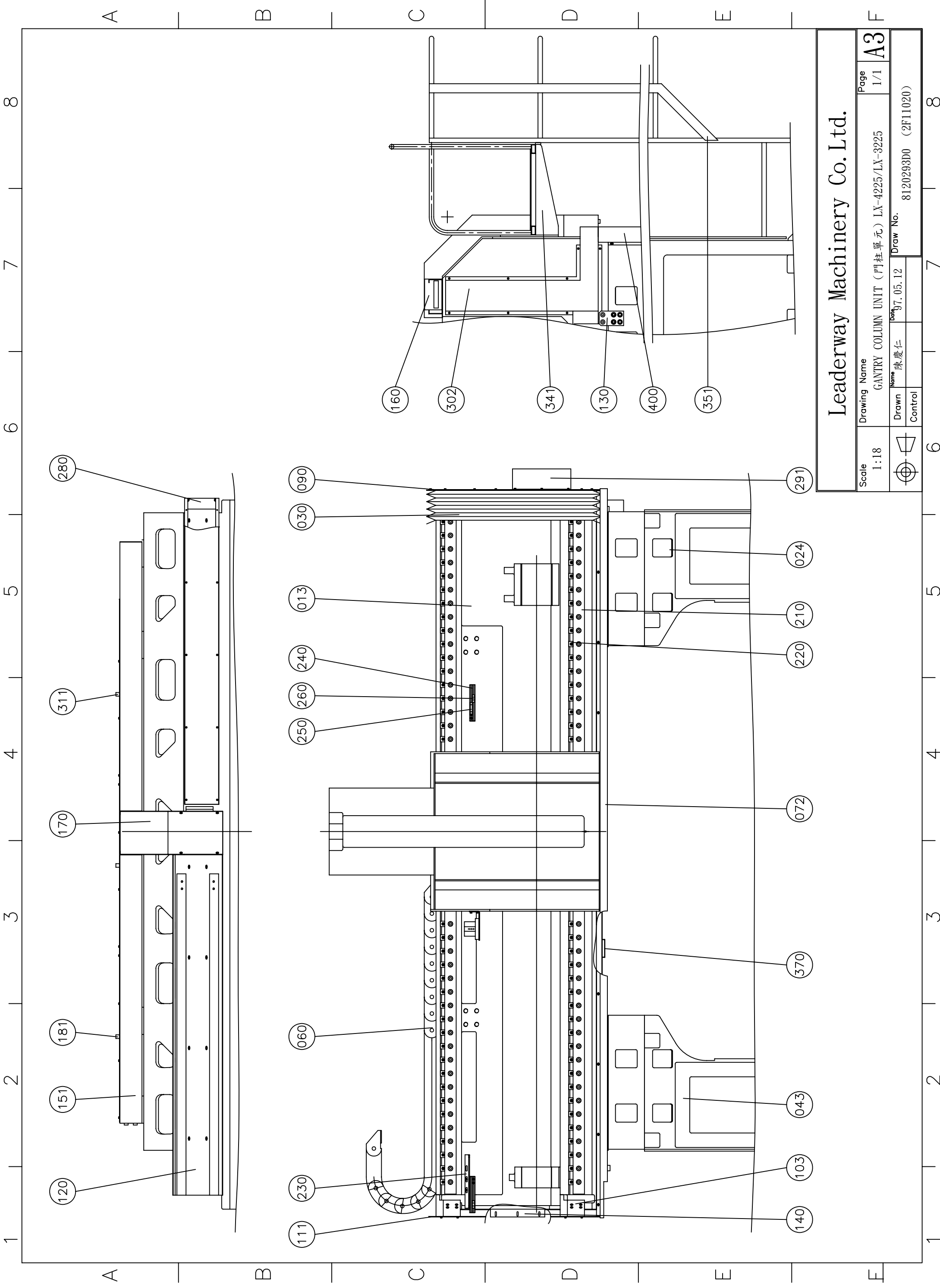

Leaderway Machinery Co. Ltd.

Scale	1:18	Drawing Name	GANTRY COLUMN UNIT (門柱單元) LX-4225/LX-3225	Page	1/1
		Drawn	陳慶仁	Date	97.05.12
		Control		Draw No.	8120293D0 (2F11020)

A3

1 2 3 4 5 6 7 8

*單階材料用量清單

製表日期: 102-01-03

第1頁

主件品號	序號	元件品號	品名 英文品名	規 格	用 量
2F11020			門柱單元(高)2284mm GANTRY COLUMN UNIT	LX-4225/3225	
	0013	3603041E0	橫樑 GANTRY	1020\FC-30\3603041A2\LX4225	1
	0024	3603088F0	門柱(右) GANTRY COLUMN	1020\FC-30\3603040B2\LX4225	1
	0030	3603058B0	伸縮護罩 TELESCOPIC BARREL	7400\SPCC	2
	0043	3603087E0	門柱(左) GANTRY COLUMN	1020\FC-30\3603040B2\LX4225	1
	0050	3603059A0	墊片(滑塊) PAD	3180\S45C	4
	0060	4640055200	方型聯動管 WIRE CONDUIT	CBO0520-55x200-404-24P/R16C	1
	0072	3603060C0	油槽 OIL TROUGH	7520\SPCC	1
	0082	3603061D0	支架(右側蓋板) SUPPORTING BRACKET	7210\SPCC	2
	0091	3603075C0	側蓋板(橫樑)右 RIGHT SIDE COVER	7500\SPCC	1
	0103	3603076E0	支架(左側蓋板) SUPPORTING BRACKET	7210\SPCC	2
	0111	3603077C0	側蓋板(橫樑)左 LEFT SIDE COVER	7500\SPCC	1
	0120	3603078A0	槽座(連動管) CONDUIT BRACKET	7210\SPCC	1
	0130	3603080A0	調整座 ADJUSTABLE BRACKET	3160\SS41	2
	0140	3603081A0	支架(側蓋板) SUPPORTING BRACKET	7210\SPCC	2
	0151	3603082C0	線槽 CONDUIT	7530\SPCC	1
	0160	3603083A0	線槽 CONDUIT	7530\SPCC	1
	0170	3603084A0	蓋板 COVER	7210\SPCC	1
	0181	3603085C0	蓋板 COVER	7210\SPCC	1
	0200	3603086B0	配管槽 PIPING TROUGH	7210\SPCC	1
	0210	3985027A0	線性滑軌(滾柱型) LINEAR GUIDE(CYLINDRIC ROLLER 1	9840\LX4225\Y軸	1

<續下頁>

*單階材料用量清單

製表日期: 102-01-03

第2頁

主件品號	序號	元件品號	品名 英文品名	規 格	用 量
2F11020	0220	3560129A0	斜楔T-3 WEDGE	9280\粉末冶金	100
	0240	3580048A0	碰塊座 DOG BRACKET	4140\AL(200m/m*2軌)	1
	0250	3540007A0	碰塊 DOG	4140\AL 外購65L	1
	0260	3500081A0	碰塊 DOG	3140\SS41(42m/m)	2
	0270	3603197A0	配線槽蓋 ELECTRICAL CONDUIT COVER	7540\SPCC	1
	0280	3603198A0	分油座 OIL DISTRIBUTOR BRACKET	4150\AL	1
	0292	3603210C0	馬達護蓋 MOTOR COVER	7170\SPCC	1
	0302	3603211D0	配管護蓋 PIPING TROUGH COVER	7210\SPCC	1
	0311	3603214B0	線槽蓋板 CONDUIT COVER	7550\SPCC	2
	0321	3603121B0	調整座 ADJUSTABLE BRACKET	3160\SS41	2
	0341	3603194C0	護欄 PROTECTING FENCE	4420\鐵管	1
	0351	3603314A0	工作梯 WORKING LADDER	4420\鐵管	1
	0361	3603070B0	電線保護蓋 WIRING COVER	7210\SPCC	1
	0370	3603224A0	橫樑下蓋板(一) GANTRY LOWER COVER(1)	7510\SPCC\LX4225\3225\5225	2
	0380	3603246A0	橫樑下蓋板(二) GANTRY LOWER COVER(2)	7510\SPCC\LX4225\3225\5225	1
	0401	3603535A0	遮板 COVER	7210\SPCC	1
	0420	3603279A0	儲油桶座 OIL REVIO BRACKET	7210\SPCC	1
	0430	4010030100	六角承窩螺絲 HEX. SOCKET SCREW	M30xP3.5x100L	34
	0440	4010330090	外六角頭螺絲(S45C 染黑) HEX. HEAD BOLT	M30xP3.5x90L	12
	0450	4640610520	方型聯動管隔板 WIRE CONDUIT SEPARATOR	CBO0520	60
	0460	4510110005	塑膠油桶 BARREL	5公升	1

<續下頁>

*單階材料用量清單

製表日期: 102-01-03

第3頁

主件品號	序號	元件品號	品名 英文品名	規 格	用 量
2F11020	0470	3603575A0	碰塊座 DOG BRACKET	4140\AL(430m/m*2軌)	1
	0480	3603583A0	碰塊 DOG	SPCC\350長	1
	0491	3603587B0	電氣盒(門柱) TERMINAL BOX	7210\SPCC	1
	0500	3603593A0	電氣盒蓋 TERMINAL BOX COVER	7210\SPCC	1

<結 束>

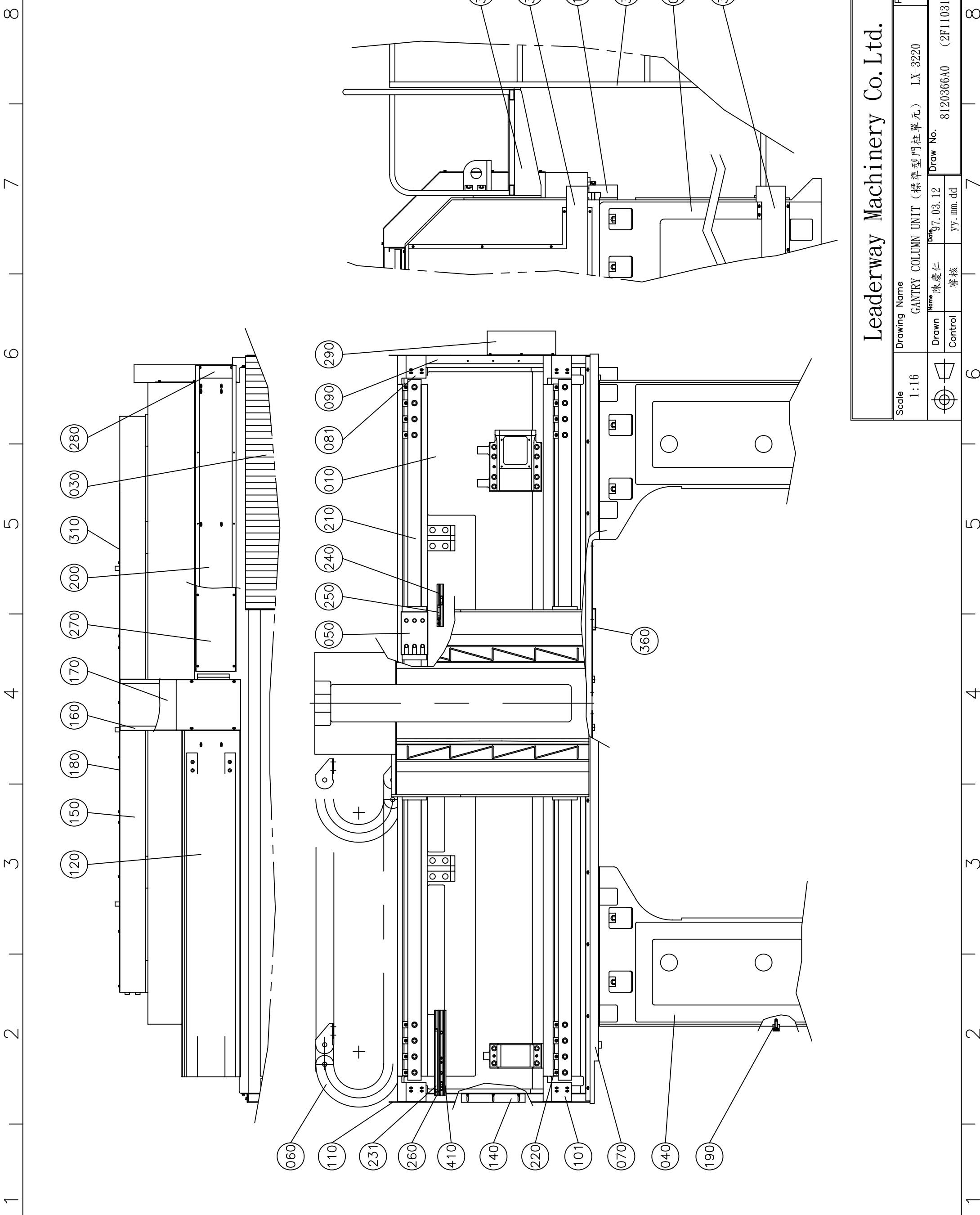

Scale 1:16		Drawing Name GANTRY COLUMN UNIT (標準型門柱單元) LX-3220		Page 1/1
		Drawn 陳慶仁		Draw No. 8120366A0 (2F11031)
Date 97.03.12		Control 審核		8
Date yy. mm. dd		Control 審核		8

Leaderway Machinery Co. Ltd.

*單階材料用量清單

製表日期: 102-12-10

第1頁

主件品號	序號	元件品號	品名 英文品名	規 格	用 量
2F11031			門柱單元(短)2084mm GANTRY COLUMN UNIT	LX-3220	
	0010	3603251A0	橫樑 GANTRY	1020\請改下3603251B0	1
	0021	3603402B0	門柱(右) GANTRY COLUMN	1010\請改下3603402C0	1
	0030	3603252A0	伸縮式護罩 TELESCOPIC BARREL	7400\SPCC	2
	0041	3603401B0	門柱(左) GANTRY COLUMN	1010\請改下3603401C0	1
	0050	3603059A0	墊片(滑塊) PAD	3180\S45C	4
	0060	4640201932	方型聯動管(CB00520) WIRE CONDUIT	KY-CE-55*200-404-21P-R160	1
	0070	3603255A0	油槽 OIL TROUGH	7520\請改下3603255B0	1
	0081	3603061D0	支架(右側蓋板) SUPPORTING BRACKET	7210\SPCC	2
	0090	3603075B0	側蓋板(橫樑)右 RIGHT SIDE COVER	7500\請改下3603075C0	1
	0101	3603076D0	支架(左側蓋板) SUPPORTING BRACKET	7210\請改下3603076E0	2
	0110	3603077B0	側蓋板(橫樑)左 LEFT SIDE COVER	7500\請改下3603077C0	1
	0120	3603256A0	槽座(連動管) CONDUIT BRACKET	7210\SPCC	1
	0140	3603081A0	支架(側蓋板) SUPPORTING BRACKET	7210\SPCC	2
	0150	3603257A0	線槽 CONDUIT	7530\SPCC	1
	0160	3603083A0	線槽 CONDUIT	7530\SPCC	1
	0170	3603084A0	蓋板 COVER	7210\SPCC	1
	0190	3603115B0	刀庫連座檔塊 STOPPER	3140\SS41	2
	0200	3603260A0	配管槽 PIPING TROUGH	7210\SPCC	1
	0210	3985035A0	線性滑軌(滾柱型) LINEAR GUIDE(CYLINDRIC ROLLER 1	9840\LX3220\Y軸	1
	0220	3560129A0	斜楔T-3 WEDGE	9280\粉末冶金	88

<續下頁>

*單階材料用量清單

製表日期: 102-12-10

第2頁

主件品號	序號	元件品號	品名 英文品名	規 格	用 量
2F11031	0231	3540002A0	碰塊 DOG	3140\SS41 外購300長	1
	0240	3580048A0	碰塊座 DOG BRACKET	4140\AL(200m/m*2軌)	1
	0250	3540007A0	碰塊 DOG	4140\AL 外購65L	1
	0260	3500081A0	碰塊 DOG	3140\SS41(42m/m)	2
	0270	3603262A0	蓋板(配線槽) ELECTRICAL CONDUIT COVER	7540\SPCC	1
	0280	3603198A0	分油座 OIL DISTRIBUTOR BRACKET	4150\AL	1
	0290	3603210B0	馬達護蓋 MOTOR COVER	7170\請改下3603210C0	1
	0301	3603211D0	配管護蓋 PIPING TROUGH COVER	7210\SPCC	1
	0310	3603259A0	蓋板(線槽) CONDUIT COVER	7550\SPCC	1
	0330	3603263A0	護欄(LX-3220) PROTECTING FENCE	4420\鐵管	1
	0340	3603512A0	工作梯(LX-B標準門柱用) WORKING LADDER	4420\鐵管	1
	0350	3603070A0	電線保護蓋 WIRING COVER	7210\請改下3603070B0	1
	0360	3603264A0	橫樑下蓋板 GANTRY LOWER COVER	7510\SPCC\LX3220	2
	0370	3603466A0	遮板 COVER	7210\SPCC	1
	0390	4010030100	六角承窩螺絲 HEX. SOCKET SCREW	M30xP3.5x100L	34
	0410	3171684C0	碰塊座 DOG BRACKET	4140\AL(400m/m*4軌)	1
	0420	4640610520	方型聯動管隔板 WIRE CONDUIT SEPARATOR	CBO0520	60

<結 束>

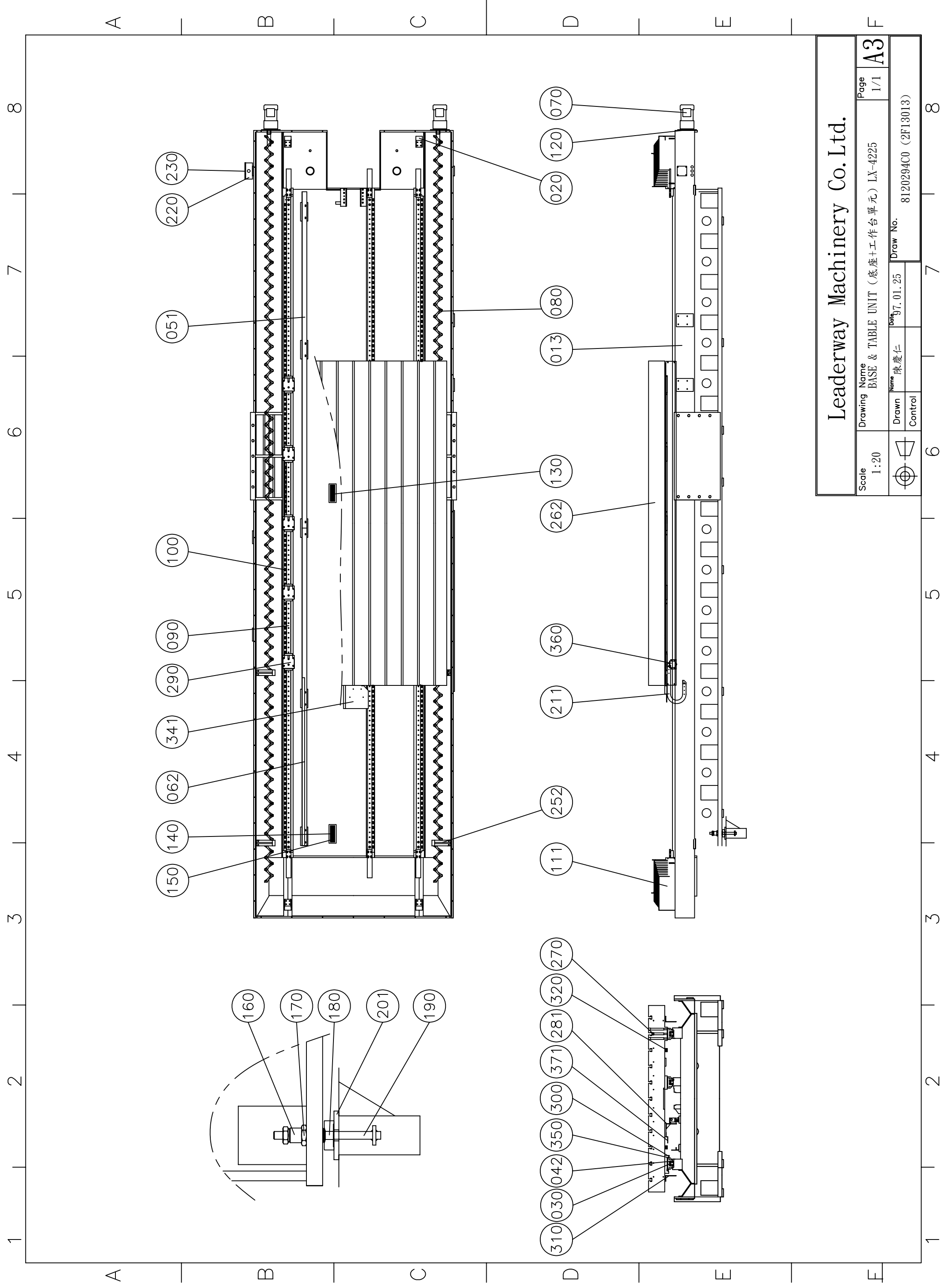

*單階材料用量清單

製表日期: 102-01-03

第1頁

主件品號	序號	元件品號	品名 英文品名	規 格	用 量
2F13013			底座+工作台單元 BASE + TABLE UNIT	LX-4225	
	0013	3603045E0	底座 BASE	3030\SS41\3603045D2\LX4225	1
	0020	3603101A0	摺動罩側支架 TELESCOPIC COVER BRACKET	7210\SPCC	4
	0030	3603102B0	摺動罩支架 TELESCOPIC COVER BRACKET	3180\SS41	6
	0042	3603103D0	摺動罩支架墊塊 TELESCOPIC COVER BRACKET PAD	3210\SS41	6
	0051	3603104C0	連動管前支架 FRONT BRACKET, CONDUIT	7210\SPCC	1
	0062	3603105D0	連動管支架 CONDUIT BRACKET	7210\SPCC	1
	0070	4440812028	馬達(排屑器用) CONVEYOR MOTOR		2
	0080	3603106A0	螺旋排屑器 CHIP CONVEYOR	9570	2
	0090	3985026A0	線性滑軌(滾柱型) LINEAR GUIDE(CYLINDRIC ROLLER)	9840\LX4225\X軸	1
	0100	3560129A0	斜楔T-3 WEDGE	9280\粉末冶金	402
	0111	3603154B0	X軸摺動罩 X AXIS TELESCOPIC COVER UNIT	7400\SPCCZ	2
	0120	3602005A0	馬達板(螺旋排屑器) MOTOR BRACKET	3170\SS41	2
	0130	3540003A0	碰塊座 DOG BRACKET	4140\AL(200m/m*4軌)	2
	0140	3540005A0	碰塊 DOG	3140\SS41 外購89長	1
	0150	3540007A0	碰塊 DOG	4140\AL 外購65L	2
	0160	3541001C0	地基螺絲 FOUNDATION BOLT	3310\S45C	44
	0170	3540006A0	螺帽 NUT	3310\S45C	44
	0180	3603132A0	地基螺絲墊塊 FOUNDATION PAD	3230\S45C	44
	0211	4640026098	方型聯動管 WIRE CONDUIT	KY-CE(CB004)-26x98-142-53P/	1
	0240	3603119A0	摺動罩後蓋板 TELESCOPIC COVER REAR COVER	7510\SPCC	1

<續下頁>

*單階材料用量清單

製表日期: 102-01-03

第2頁

主件品號	序號	元件品號	品名 英文品名	規 格	用 量
2F13013	0252	3603560A0	排屑器壓板 LOCKING PLATE	SPCC	12
	0262	3603044D0	工作台 TABLE	1050\FC-30\3603044C2\LX4225	1
	0270	3603123A0	塞頭(工作台) TABLE SEALED CORK	3310\S45C	90
	0281	3603124C0	連動管上固定座 UPPER BRACKET, CONDUIT	7210\SPCC	1
	0300	3603126A0	側面墊片座 SIDE PAD BRACKET	7180\SPCC	4
	0310	3603127B0	工作台側蓋板 TABLE SIDE COVER	7510\SPCC\LX4225	4
	0320	3603128A0	油管座 OIL PIPE BRACKET	7210\SPCC	2
	0330	3603217A0	線槽 CONDUIT	7530\SPCC	1
	0341	3603129D0	配油座固定板 LUBRICANT DISTRIBUTOR BRACKET	7210\SPCC	1
	0353	3170514D0	滑塊側面墊片 SLIDING BLOCK PAD	3180\S45C	4
	0360	4800140210	微動開關(2聯滾珠型) MICRO SWITCH	BNS819-D02-L12-100-10	1
	0371	3603189B0	連動管固定座 CONDUIT BRACKET	7210\SPCC	1
	0380	4070161060	雙圓頭平行鍵 DOUBLE ROUND KEY	16x10x60L	2
	0391	3603223B0	滾輪(連動管) ROLLER	4370\MC	2
	0400	3603233A0	底座後蓋板 BASE REAR COVER	7510\SPCC\LX4225\3220\3225	1
	0410	3603237A0	線管座 CONDUIT BRACKET	7210\SPCC	14
	0450	3500074C0	塞頭(工作台) TABLE SEALED CORK	3310\S45C	8
	0460	3174767B0	蓋板(偵測器用) COVER	7180\SPCC	1
	0470	3603588A0	電氣盒(底座) TERMINAL BOX	7210\SPCC	1
	0480	3603593A0	電氣盒蓋 TERMINAL BOX COVER	7210\SPCC	1
	0490	3603590A0	地基墊片 PAD	3180\SS41	44

<續下頁>

*單階材料用量清單

製表日期: 102-01-03

第3頁

主件品號	序號	元件品號	品名 英文品名	規 格	用 量
2F13013	0500	3603591A0	地基螺絲(地錨) FOUNDATION BOLT	4310\牙條	44
	0510	4020000024	外六角螺帽 NUT	M24xP3.0	44
	0520	4040500024	鍍鎳厚平墊圈 WASHER	M24 24*42*5T	44

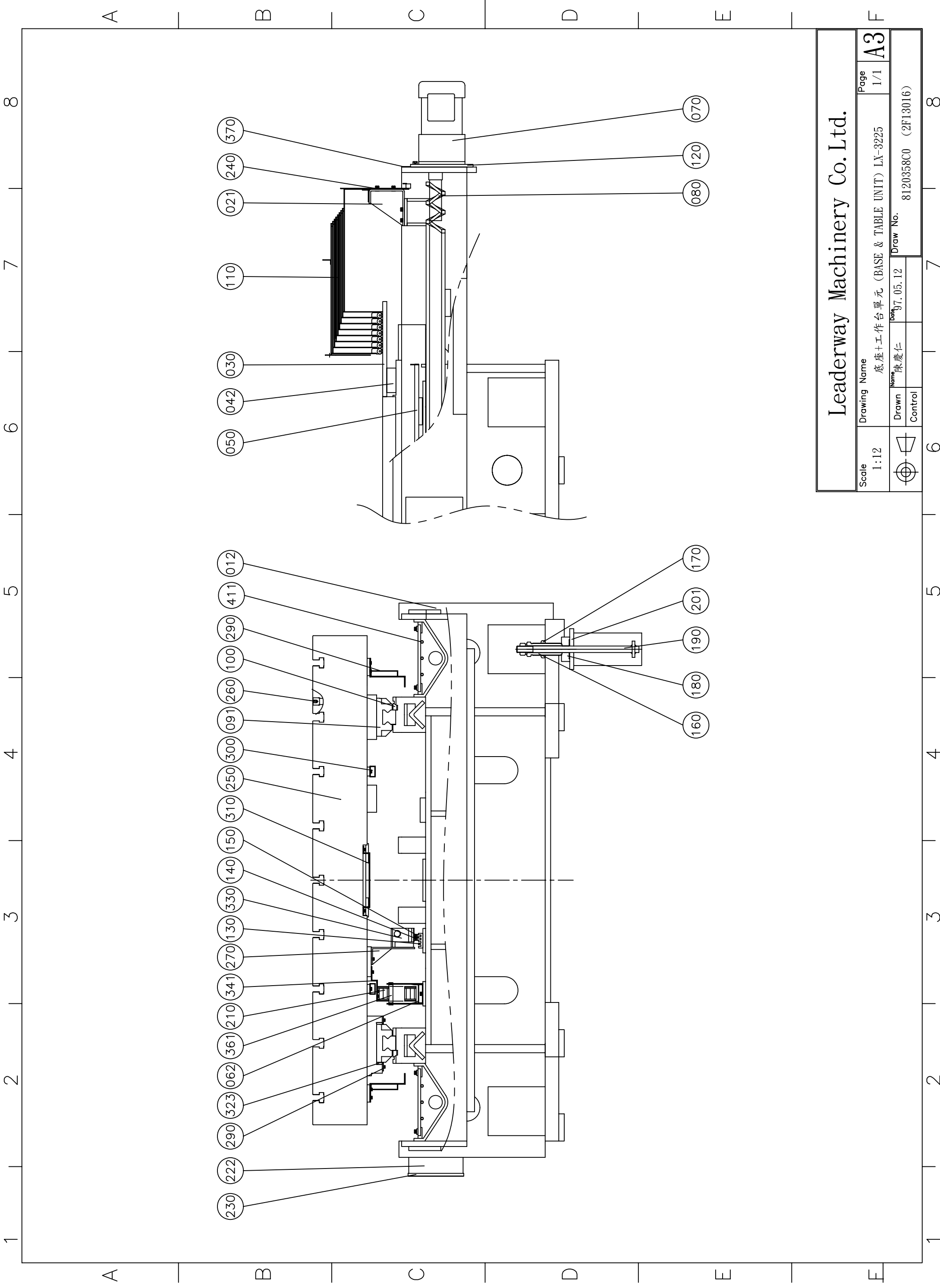

Scale 1:12		Drawing Name 底座+工作台單元 (BASE & TABLE UNIT) LX-3225		Page 1/1
		Leaderway Machinery Co. Ltd.		A3
	Drawn 陳慶仁	Date 97.05.12	Draw No. 8120358C0 (2F13016)	
	Control			

*單階材料用量清單

製表日期: 102-01-03

第1頁

主件品號	序號	元件品號	品名 英文品名	規 格	用 量
2F13016			底座+工作台單元 BASE + TABLE UNIT	LX-3225	
	0012	3603312C0	底座 BASE	3030\SS41\3603312B2\LX3225	1
	0021	3603467A0	摺動罩側支架 TELESCOPIC COVER BRACKET	7210\SPCC	4
	0030	3603102B0	摺動罩支架 TELESCOPIC COVER BRACKET	3180\SS41	6
	0042	3603103D0	摺動罩支架墊塊 TELESCOPIC COVER BRACKET PAD	3210\SS41	6
	0050	3603358A0	連動管前支架 FRONT BRACKET, CONDUIT	7210\SPCC	1
	0062	3603265C0	連動管支架 CONDUIT BRACKET	7210\SPCC	1
	0070	4440812028	馬達(排屑器用) CONVEYOR MOTOR		2
	0080	3603356A0	螺旋排屑器 CHIP CONVEYOR	9570\φ 108-5/8"*1-1/4"-7000	2
	0091	3985044B0	線性滑軌(滾柱型) LINEAR GUIDE(CYLINDRIC ROLLER)	9840\LX3225	1
	0100	3560129A0	斜楔T-3 WEDGE	9280\粉末冶金	300
	0110	3603355A0	摺動罩 TELESCOPIC COVER UNIT	7400\SPCCZ	2
	0120	3602005A0	馬達板(螺旋排屑器) MOTOR BRACKET	3170\SS41	2
	0130	3540003A0	碰塊座 DOG BRACKET	4140\AL(200m/m*4軌)	2
	0140	3540005A0	碰塊 DOG	3140\SS41 外購89長	1
	0150	3540007A0	碰塊 DOG	4140\AL 外購65L	2
	0160	3541001C0	地基螺絲 FOUNDATION BOLT	3310\S45C	36
	0170	3540006A0	螺帽 NUT	3310\S45C	36
	0180	3603132A0	地基螺絲墊塊 FOUNDATION PAD	3230\S45C	36
	0240	3603119A0	摺動罩後蓋板 TELESCOPIC COVER REAR COVER	7510\SPCC	1
	0250	3603311A0	工作台 TABLE	1050\FC-30\3603311A2\LX3225	1

<續下頁>

*單階材料用量清單

製表日期: 102-01-03

第2頁

主件品號	序號	元件品號	品名 英文品名	規 格	用 量
2F13016	0260	3603123A0	塞頭(工作台) TABLE SEALED CORK	3310\S45C	72
	0270	3603124C0	連動管上固定座 UPPER BRACKET, CONDUIT	7210\SPCC	1
	0280	3603126A0	側面墊片座 SIDE PAD BRACKET	7180\SPCC	4
	0290	3603375A0	工作台側蓋板 TABLE SIDE COVER	7510\SPCC\LX3225	2
	0300	3603270B0	油管座 OIL PIPE BRACKET	7210\SPCC	2
	0310	3603129D0	配油座固定板 LUBRICANT DISTRIBUTOR BRACKET	7210\SPCC	1
	0323	3170514D0	滑塊側面墊片 SLIDING BLOCK PAD	3180\S45C	4
	0330	4800140210	微動開關(2聯滾珠型) MICRO SWITCH	BNS819-D02-L12-100-10	1
	0341	3603189B0	連動管固定座 CONDUIT BRACKET	7210\SPCC	1
	0350	4070161060	雙圓頭平行鍵 DOUBLE ROUND KEY	16x10x60L	2
	0361	3603223B0	滾輪(連動管) ROLLER	4370\MC	2
	0370	3603233A0	底座後蓋板 BASE REAR COVER	7510\SPCC\LX4225\3220\3225	1
	0380	3603237A0	線管座 CONDUIT BRACKET	7210\SPCC	10
	0411	3603559A0	排屑器壓板 LOCKING PLATE	SPCC	10
	0430	3500074C0	塞頭(工作台) TABLE SEALED CORK	3310\S45C	8
	0440	4640026198	方型聯動管 WIRE CONDUIT	KY-CE(CB004)-26x98-142-45P/	1
	0450	3174767B0	蓋板(偵測器用) COVER	7180\SPCC	1
	0460	3603588A0	電氣盒(底座) TERMINAL BOX	7210\SPCC	1
	0470	3603593A0	電氣盒蓋 TERMINAL BOX COVER	7210\SPCC	1
	0480	3603590A0	地基墊片 PAD	3180\SS41	36
	0490	3603591A0	地基螺絲(地錨) FOUNDATION BOLT	4310\牙條	36

<續下頁>

*單階材料用量清單

製表日期: 102-01-03

第3頁

主件品號	序號	元件品號	品名 英文品名	規 格	用 量
2F13016	0500	4020000024	外六角螺帽 NUT	M24xP3.0	36
	0510	4040500024	鍍鎳厚平墊圈 WASHER	M24 24*42*5T	36

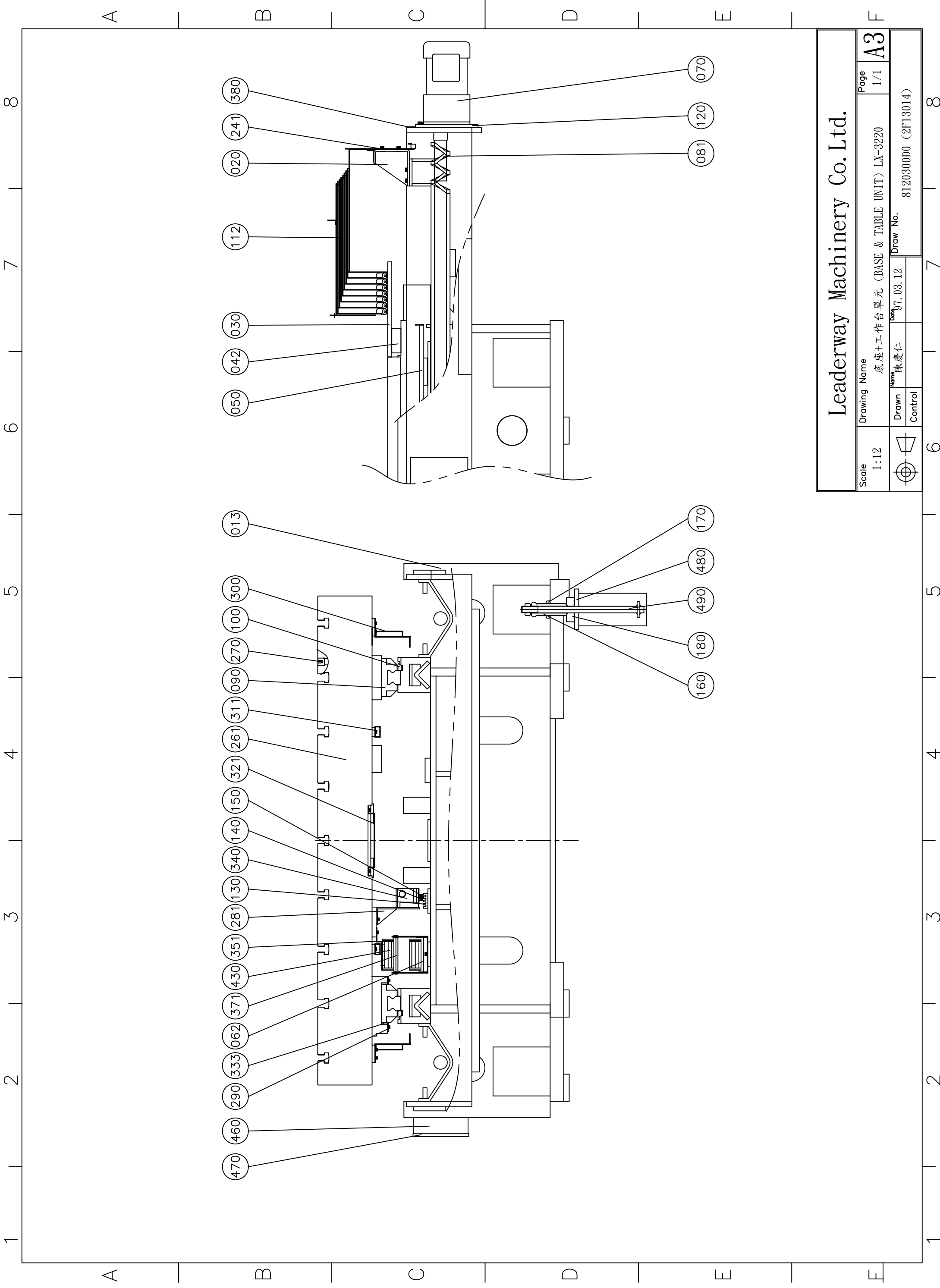

Leaderway Machinery Co. Ltd.			
Scale	Drawing Name	Page	
1:12	底座+工作台單元 (BASE & TABLE UNIT) LX-3220	1/1	A3
	Drawn	Draw No.	
	陳慶仁	8120300D0 (2F13014)	
	Date		
	97.03.12		

*單階材料用量清單

製表日期: 102-01-03

第1頁

主件品號	序號	元件品號	品名 英文品名	規 格	用 量
2F13014			底座+工作台單元 BASE + TABLE UNIT	LX-3220	
	0013	3603250D0	底座 BASE	3030\SS41\3603250C2\LX3220	1
	0020	3603101A0	摺動罩側支架 TELESCOPIC COVER BRACKET	7210\SPCC	4
	0030	3603102B0	摺動罩支架 TELESCOPIC COVER BRACKET	3180\SS41	4
	0042	3603103D0	摺動罩支架墊塊 TELESCOPIC COVER BRACKET PAD	3210\SS41	4
	0050	3603307A0	連動管前支架 FRONT BRACKET, CONDUIT	7210\SPCC	1
	0062	3603265C0	連動管支架 CONDUIT BRACKET	7210\SPCC	1
	0070	4440812028	馬達(排屑器用) CONVEYOR MOTOR		2
	0081	3603356A0	螺旋排屑器 CHIP CONVEYOR	9570\φ 108-5/8"*1-1/4"-7000	2
	0090	3985036A0	線性滑軌(滾柱型) LINEAR GUIDE(CYLINDRIC ROLLER)	9840\LX3220\X軸	1
	0100	3560129A0	斜楔T-3 WEDGE	9280\粉末冶金	200
	0112	3603267C0	摺動罩組件 TELESCOPIC COVER UNIT	9400\SPCCZ	2
	0120	3602005A0	馬達板(螺旋排屑器) MOTOR BRACKET	3170\SS41	2
	0130	3540003A0	碰塊座 DOG BRACKET	4140\AL(200m/m*4軌)	2
	0140	3540005A0	碰塊 DOG	3140\SS41 外購89長	1
	0150	3540007A0	碰塊 DOG	4140\AL 外購65L	2
	0160	3541001C0	地基螺絲 FOUNDATION BOLT	3310\S45C	36
	0170	3540006A0	螺帽 NUT	3310\S45C	36
	0180	3603132A0	地基螺絲墊塊 FOUNDATION PAD	3230\S45C	36
	0261	3603261B0	工作台 TABLE	1050\FC-30\3603261A2\LX3220	1
	0270	3603123A0	塞頭(工作台) TABLE SEALED CORK	3310\S45C	48

<續下頁>

*單階材料用量清單

製表日期: 102-01-03

第2頁

主件品號	序號	元件品號	品名 英文品名	規 格	用 量
2F13014	0281	3603124C0	連動管上固定座 UPPER BRACKET, CONDUIT	7210\SPCC	1
	0290	3603126A0	側面墊片座 SIDE PAD BRACKET	7180\SPCC	4
	0300	3603269A0	工作台側蓋板 TABLE SIDE COVER	7510\SPCC\LX3220	2
	0311	3603270B0	油管座 OIL PIPE BRACKET	7210\SPCC	2
	0321	3603129D0	配油座固定板 LUBRICANT DISTRIBUTOR BRACKET	7210\SPCC	1
	0333	3170514D0	滑塊側面墊片 SLIDING BLOCK PAD	3180\S45C	4
	0340	4800140210	微動開關(2聯滾珠型) MICRO SWITCH	BNS819-D02-L12-100-10	1
	0351	3603189B0	連動管固定座 CONDUIT BRACKET	7210\SPCC	1
	0371	3603223B0	滾輪(連動管) ROLLER	4370\MC	2
	0380	3603233A0	底座後蓋板 BASE REAR COVER	7510\SPCC\LX4225\3220\3225	1
	0390	3603237A0	線管座 CONDUIT BRACKET	7210\SPCC	10
	0420	3500074C0	塞頭(工作台) TABLE SEALED CORK	3310\S45C	8
	0430	4640026198	方型聯動管 WIRE CONDUIT	KY-CE(CB004)-26x98-142-45P/	1
	0440	3603555A0	排屑器壓板 LOCKING PLATE	SPCC	10
	0450	3174767B0	蓋板(偵測器用) COVER	7180\SPCC	1
	0460	3603588A0	電氣盒(底座) TERMINAL BOX	7210\SPCC	1
	0470	3603593A0	電氣盒蓋 TERMINAL BOX COVER	7210\SPCC	1
	0480	3603590A0	地基墊片 PAD	3180\SS41	36
	0490	3603591A0	地基螺絲(地錨) FOUNDATION BOLT	4310\牙條	36
	0500	3603268B0	摺動罩後蓋板 TELESCOPIC COVER REAR COVER	7210\SPCC	1
	0510	4020000024	外六角螺帽 NUT	M24xP3.0	36

<續下頁>

*單階材料用量清單

製表日期: 102-01-03

第3頁

主件品號	序號	元件品號	品名 英文品名	規 格	用 量
2F13014	0520	4040500024	鍍鎳厚平墊圈 WASHER	M24 24*42*5T	36

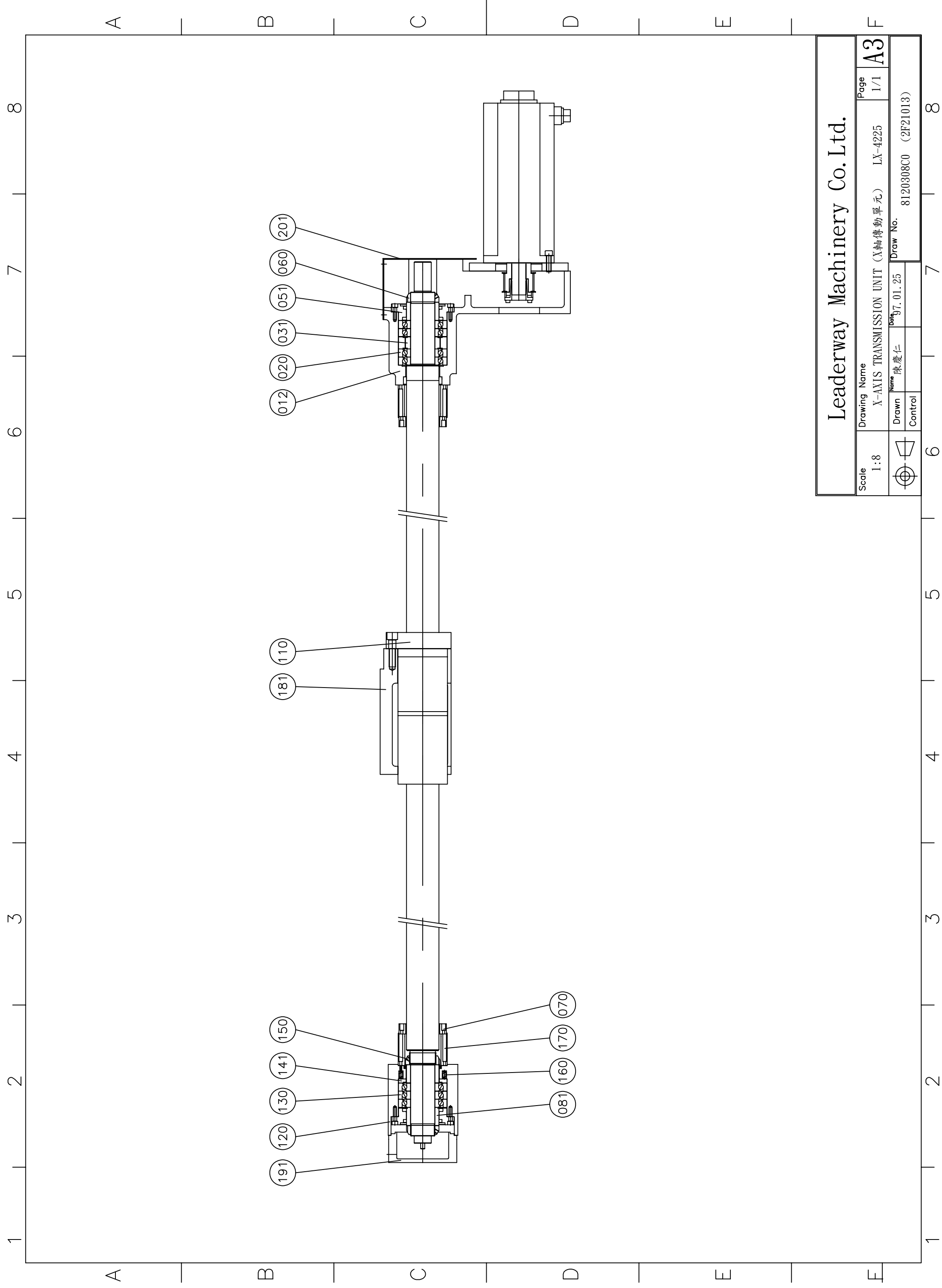

Leaderway Machinery Co. Ltd.

Scale	1:8	Drawing Name	X-AXIS TRANSMISSION UNIT (X軸傳動單元)	LX-4225	Page	1/1
		Drawn	陳慶仁	8120308C0 (2F21013)	A3	
		Control				
		Date	97.01.25	Draw No.		

*單階材料用量清單

製表日期: 102-01-03

第1頁

主件品號	序號	元件品號	品名 英文品名	規 格	用 量
2F21013			X軸傳動單元 X AXIS TRANSMISSION UNIT	LX-4225	
	0012	3603199C0	傳動箱(X軸) TRANSMISSION HOUSING	1500\FC-30\3603199B2	1
	0020	4402260120	螺桿軸承 BALL SCREW BEARING	NSK:60TAC 120B-DBB	1
	0031	3603201B0	軸承隔環組 BEARING SPACER	9230\SCM4	1
	0051	3603200B0	軸承壓蓋 BEARING CAP	3240\SCM4	2
	0060	4020403060	鎖緊螺帽 LOCK NUT	MF60x2.0P D80xh22	2
	0070	3603117A0	防撞膠 RUBBER CUSHION	4370\PU	2
	0081	3603202B0	隔環 SPACER	3230\SCM4	3
	0110	3984033A0	滾珠螺桿 X AXIS BALL SCREW	9860\LX4225\X軸	1
	0120	3603235A0	尾端軸承座 REAR BEARING HOUSING	1080\FC-30\3603235A2	1
	0130	4402260121	螺桿軸承 BALL SCREW BEARING	NSK:60TAC 120B-DTD	1
	0141	3603219B0	隔環 SPACER	3230\SCM4	1
	0150	4020403065	鎖緊螺帽 LOCK NUT	MF65x2.0P D85xh22	1
	0160	4050110032	壓縮彈簧 COMPRESSIVE SPRING	扁圓形 ϕ 10x32-1.8x1.1	8
	0170	3603234A0	固定環座(優力膠) RUBBER CUSHION BRACKET	3230\S45C	2
	0181	3603116C0	螺帽座 BALLSCREW HOUSING	1080\FC-30\3603116B2	1
	0191	3603110C0	固定座(解碼器) ENCODER BRACKET	3230\S45C	1
	0201	3603221B0	蓋板(傳動座) TRANSMISSION HOUSING COVER	7210\SPCC	1
	0220	4080508050	斜梢 SLIDE PIN	#8x50L(附內牙)	6

<結 束>

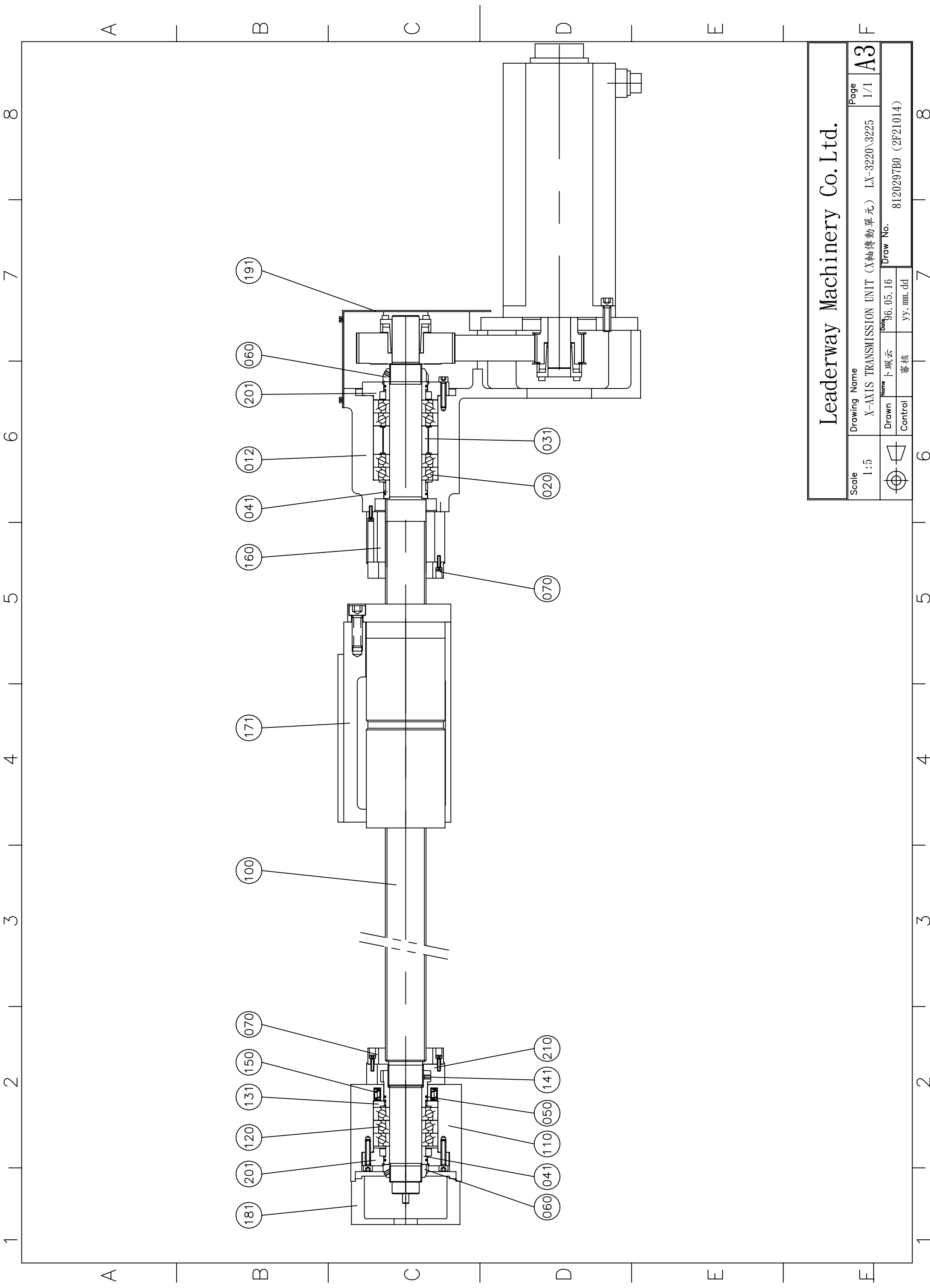

Leaderway Machinery Co. Ltd.			
Scale	Drawing Name	Page	
1:5	X-AXIS TRANSMISSION UNIT (X軸傳動單元)	1/1	A3
	Drawn	Date	Draw No.
	卜珉云	96.05.16	8120297B0 (2F21014)
	Control	審核	

*單階材料用量清單

製表日期: 102-01-03

第1頁

主件品號	序號	元件品號	品名 英文品名	規 格	用 量
2F21014			X軸傳動單元 X AXIS TRANSMISSION UNIT	LX-3220(3225)	
	0012	3603247C0	傳動箱(X軸) TRANSMISSION HOUSING	1500\FC-30\3603199B2	1
	0020	4402250100	螺桿軸承 BALL SCREW BEARING	NSK:50TAC 100B-DFD-PN7A	1
	0031	3603248B0	軸承隔環組 BEARING SPACER	9230\SCM4	1
	0041	3603095B0	迷宮環座 LAMINAL RING BRACKET	3250\SCM4	3
	0050	4061300001	迷宮環 LAMINAL RING	FK3-AS 68/2.8/0.82	12
	0060	4020403050	鎖緊螺帽 LOCK NUT	MF50x1.5P	2
	0070	3603117A0	防撞膠 RUBBER CUSHION	4370\PU	2
	0100	3984034A0	滾珠螺桿 X AXIS BALL SCREW	9860\LX3220(3225)\X軸	1
	0110	3603249A0	尾端軸承座 REAR BEARING HOUSING	1080\3603249A2	1
	0120	4402150100	螺桿軸承 BALL SCREW BEARING	NSK:50TAC-100B-DTD-PN7A	1
	0131	3603112B0	隔環(彈簧) SPACER	3230\SCM4	1
	0141	3603113B0	鎖緊螺帽(自製) LOCK NUT	3310\SCM4	1
	0150	4050110032	壓縮彈簧 COMPRESSIVE SPRING	扁圓形 ϕ 10x32-1.8x1.1	6
	0160	3603234A0	固定環座(優力膠) RUBBER CUSHION BRACKET	3230\S45C	1
	0171	3603116C0	螺帽座 BALLSCREW HOUSING	1080\FC-30\3603116B2	1
	0181	3603110C0	固定座(解碼器) ENCODER BRACKET	3230\S45C	1
	0191	3603221B0	蓋板(傳動座) TRANSMISSION HOUSING COVER	7210\SPCC	1
	0201	3603096B0	軸承壓蓋 BEARING CAP	3240\SCM4	2
	0210	3603114B0	固定環(防撞膠) RUBBER CUSHION RING BRACKET	3230\S45C	1
	0230	4080508050	斜梢 SLIDE PIN	#8x50L(附內牙)	6

<續下頁>

*單階材料用量清單

製表日期: 102-01-03

第2頁

主件品號	序號	元件品號	品名 英文品名	規 格	用 量

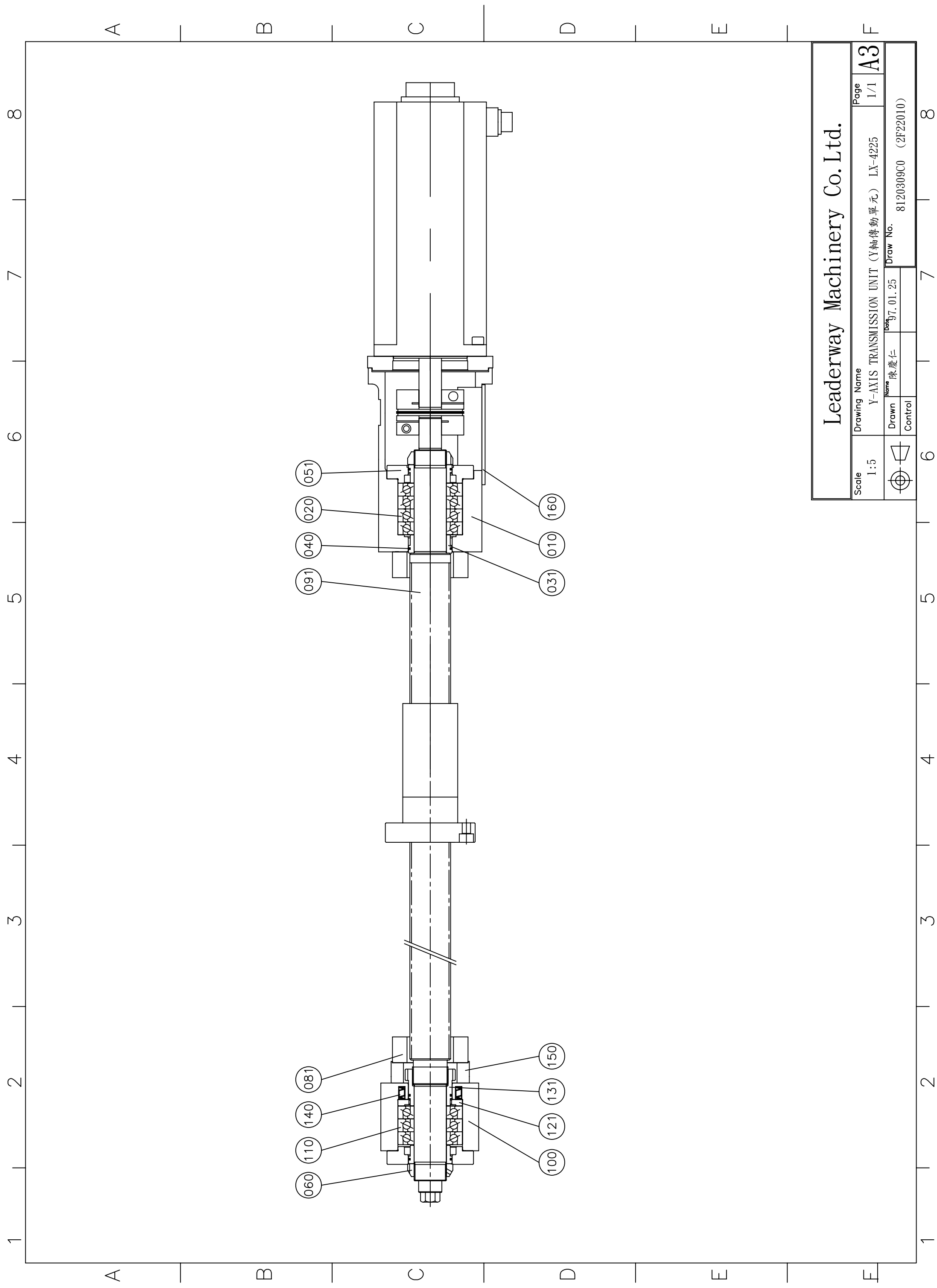

Scale 1:5		Drawing Name Y-AXIS TRANSMISSION UNIT (Y軸傳動單元) LX-4225		Page 1/1
		Leaderway Machinery Co. Ltd.		A3
	Drawn Control	Name 陳慶仁	Draw No. 8120309C0 (2F22010)	Date 97.01.25

*單階材料用量清單

製表日期: 102-12-10

第1頁

主件品號	序號	元件品號	品名 英文品名	規 格	用 量
2F22010			Y軸傳動單元 Y AXIS TRANSMISSION UNIT	LX-4225	
	0010	3603092A0	傳動座(Y軸) TRANSMISSION HOUSING	1080\請改下3603092B0	1
	0020	4402250100	螺桿軸承 BALL SCREW BEARING	NSK:50TAC 100B-DFE-PN7A	1
	0031	3603095B0	迷宮環座 LAMINAL RING BRACKET	3250\SCM4	3
	0040	4061300001	迷宮環 LAMINAL RING	FK3-AS 68/2.8/0.82	12
	0051	3603096B0	軸承壓蓋 BEARING CAP	3240\SCM4	2
	0060	4020403050	鎖緊螺帽 LOCK NUT	MF50x1.5P	2
	0080	3603098B0	防撞膠 RUBBER CUSHION	4370\請改下3603098C0	2
	0090	3984030B0	滾珠螺桿 Y AXIS BALL SCREW	9860\LX4225\Y軸	1
	0100	3603099A0	尾端軸承座 REAR BEARING HOUSING	1080\FC-30\3603099A2	1
	0110	4402150100	螺桿軸承 BALL SCREW BEARING	NSK:50TAC-100B-DTE-PN7A	1
	0121	3603112B0	隔環(彈簧) SPACER	3230\SCM4	1
	0131	3603113B0	鎖緊螺帽(自製) LOCK NUT	3310\SCM4	1
	0140	4050110032	壓縮彈簧 COMPRESSIVE SPRING	扁圓形 ϕ 10x32-1.8x1.1	6
	0150	3603114B0	固定環(防撞膠) RUBBER CUSHION RING BRACKET	3230\S45C	1
	0160	3170049A0	傳動座蓋板 TRANSMISSION HOUSING COVER	7180\請改下3170049B0	1

<結 束>

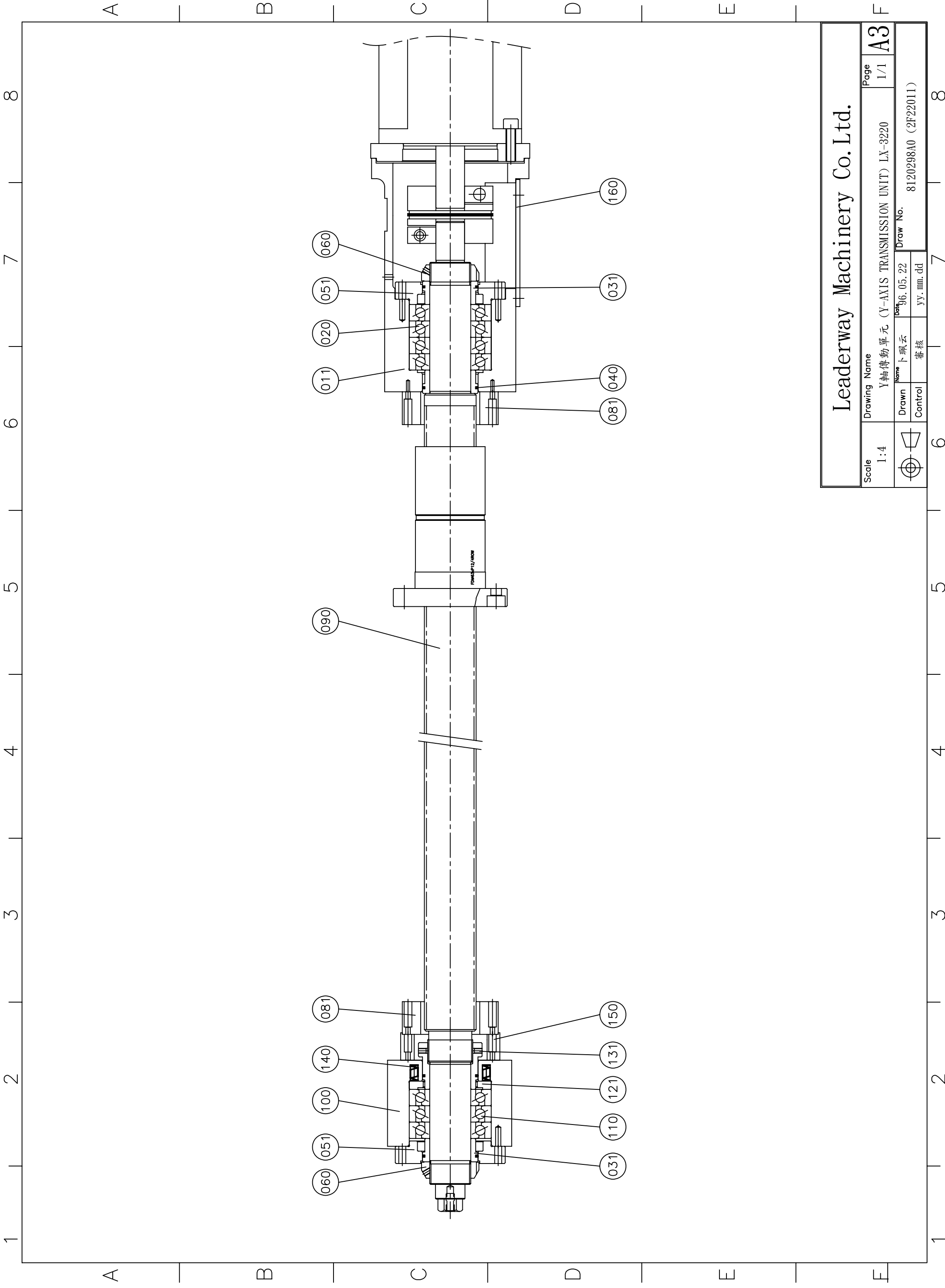

Scale 1:4		Drawing Name Y軸傳動單元 (Y-AXIS TRANSMISSION UNIT) LX-3220		Page 1/1
		Drawn 卜珉云		Draw No. 8120298A0 (2F22011)
Control		審核		8

Leaderway Machinery Co. Ltd.

*單階材料用量清單

製表日期: 102-01-03

第1頁

主件品號	序號	元件品號	品名 英文品名	規 格	用 量
2F22011			Y軸傳動單元 Y AXIS TRANSMISSION UNIT	LX-3220	
	0011	3603092B0	傳動座(Y軸)	1080\FC-25\3171305A2	1
	0020	4402250100	螺桿軸承 BALL SCREW BEARING	NSK:50TAC 100B-DFD-PN7A	1
	0031	3603095B0	迷宮環座 LAMINAL RING BRACKET	3250\SCM4	3
	0040	4061300001	迷宮環 LAMINAL RING	FK3-AS 68/2.8/0.82	12
	0051	3603096B0	軸承壓蓋 BEARING CAP	3240\SCM4	2
	0060	4020403050	鎖緊螺帽 LOCK NUT	MF50x1.5P	2
	0081	3603098C0	防撞膠 RUBBER CUSHION	4370\PU	1
	0090	3984035A0	滾珠螺桿 Y AXIS BALL SCREW	9860\LX3220\Y軸	1
	0100	3603099A0	尾端軸承座 REAR BEARING HOUSING	1080\FC-30\3603099A2	1
	0110	4402150100	螺桿軸承 BALL SCREW BEARING	NSK:50TAC-100B-DTD-PN7A	1
	0121	3603112B0	隔環(彈簧) SPACER	3230\SCM4	1
	0131	3603113B0	鎖緊螺帽(自製) LOCK NUT	3310\SCM4	1
	0140	4050110032	壓縮彈簧 COMPRESSIVE SPRING	扁圓形 ϕ 10x32-1.8x1.1	6
	0160	3170049A0	傳動座蓋板 TRANSMISSION HOUSING COVER	7180\SPCC	1
	0170	4080508050	斜梢 SLIDE PIN	#8x50L(附內牙)	4

<結 束>

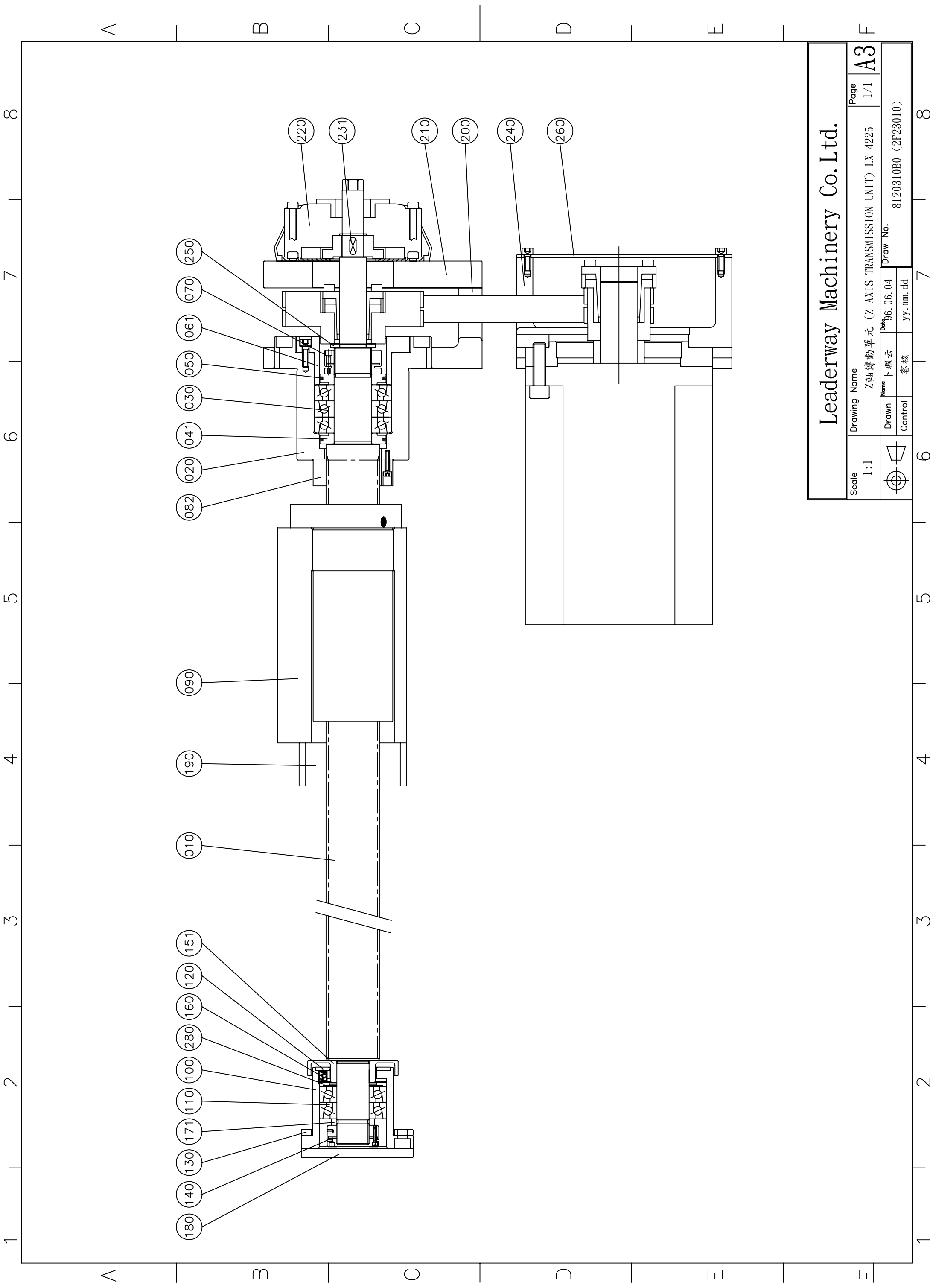

Leaderway Machinery Co. Ltd.

Scale	Drawing Name	Page
1:1	Z軸傳動單元 (Z-AXIS TRANSMISSION UNIT) LX-4225	1/1
	Date	A3
	96.06.04	
Drawn	Name	Draw No.
Control	卜珉云	8120310B0 (2F23010)
	審核	yy. mm. dd

*單階材料用量清單

製表日期: 102-01-03

第1頁

主件品號	序號	元件品號	品名 英文品名	規 格	用 量
2F23010			Z軸傳動單元 Z AXIS TRANSMISSION UNIT	LX-B Z軸行程800mm	
	0010	3984029B0	滾珠螺桿 Z AXIS BALL SCREW	9860\LX-B\Z軸\800mm	1
	0020	3603090A0	軸承座 BEARING HOUSING	3250\S45C	1
	0030	4402435072	螺桿軸承 BALL SCREW BEARING	BS35/72/15TUM	1
	0041	3170054B0	前迷宮環座 LAMINAL RING BRACKET	3250\SCM4	2
	0050	4061306828	迷宮環 LAMINAL RING	FK3-AS 62/2.8/0.82	6
	0061	3170163B0	軸承壓蓋 BEARING CAP	3240\SCM4	1
	0070	4020405035	鎖緊螺帽(軸向) AXIAL LOCK NUT	MKR-35 X1.5P	1
	0082	3560017C0	防撞膠塊 RUBBER CUSHION	4370\PU	1
	0091	3603091B0	螺帽座 BALLSCREW HOUSING	1080\FC-25\3603091A2	1
	0100	3170070A0	Z軸尾端軸承座 REAR BEARING HOUSING	3080\S45C	1
	0110	4402330062	螺桿軸承 BALL SCREW BEARING	MM30BS62DUM	1
	0120	3170067A0	預拉彈簧檔片 PRELOAD SPRING STOPPER	3230\S45C	1
	0130	3170071A0	預拉調整墊片 PRELOAD PAD	3230\S45C	1
	0140	4020401030	鎖緊螺帽 LOCK NUT	MK30	1
	0151	3170073B0	軸承隔環 BEARING SPACER	3230\SCM4	1
	0160	4050175012	壓縮彈簧 COMPRESSIVE SPRING	φ 1.25X φ 7.5X12L	8
	0171	3170057B0	軸承隔環 BEARING SPACER	3230\SCM4	1
	0180	3170072A0	Z軸尾端軸承座蓋板 PUSHING PLATE, Z AXIS BEARING	3180\S45C	1
	0190	3603228A0	Z軸螺帽防撞膠塊 RUBBER CUSHION	4370\PU	1
	0200	3170066B0	Z軸傳動連結座 Z AXIS TRANSMISSION CONNECTING	1210\FC-25\3170066A2	1

<續下頁>

*單階材料用量清單

製表日期: 102-01-03

第2頁

主件品號	序號	元件品號	品名 英文品名	規 格	用 量
2F23010	0210	3170061A0	煞車器固定座 BRAKE BRACKET	3180\S35C	1
	0220	4711202016	安全煞車器 SAFETY BRAKE	TRS-1.6KG-DC24V- ϕ 20	1
	0231	4070006616	雙圓頭平行鍵 DOUBLE ROUND KEY	6x6x16	2
	0240	3170065B0	馬達固定座(Z軸) MOTOR BRACKET	1170\FC-25\3170065A2	1
	0250	3173373A0	墊圈 WASHER	3230\S45C	1
	0260	3170062B0	馬達座蓋板 MOTOR BRACKET COVER	7170\SPCC	1
	0270	3170064B0	Z軸軸承座蓋板 BEARING HOUSING COVER	7210\SPCC	1
	0280	3170053B0	軸承隔環 BEARING SPACER	3230\SCM4	1
	0290	4080506038	斜銷(附內牙,研磨) SLIDING PIN	#6x38L	6

<結 束>

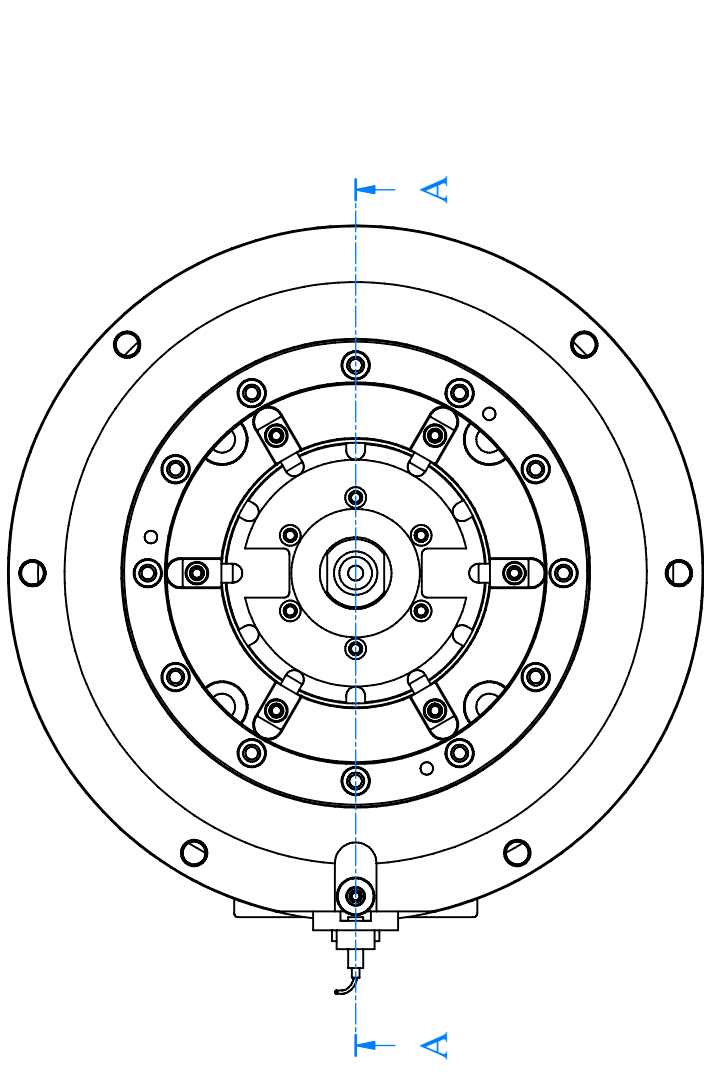

A-A (1:4)

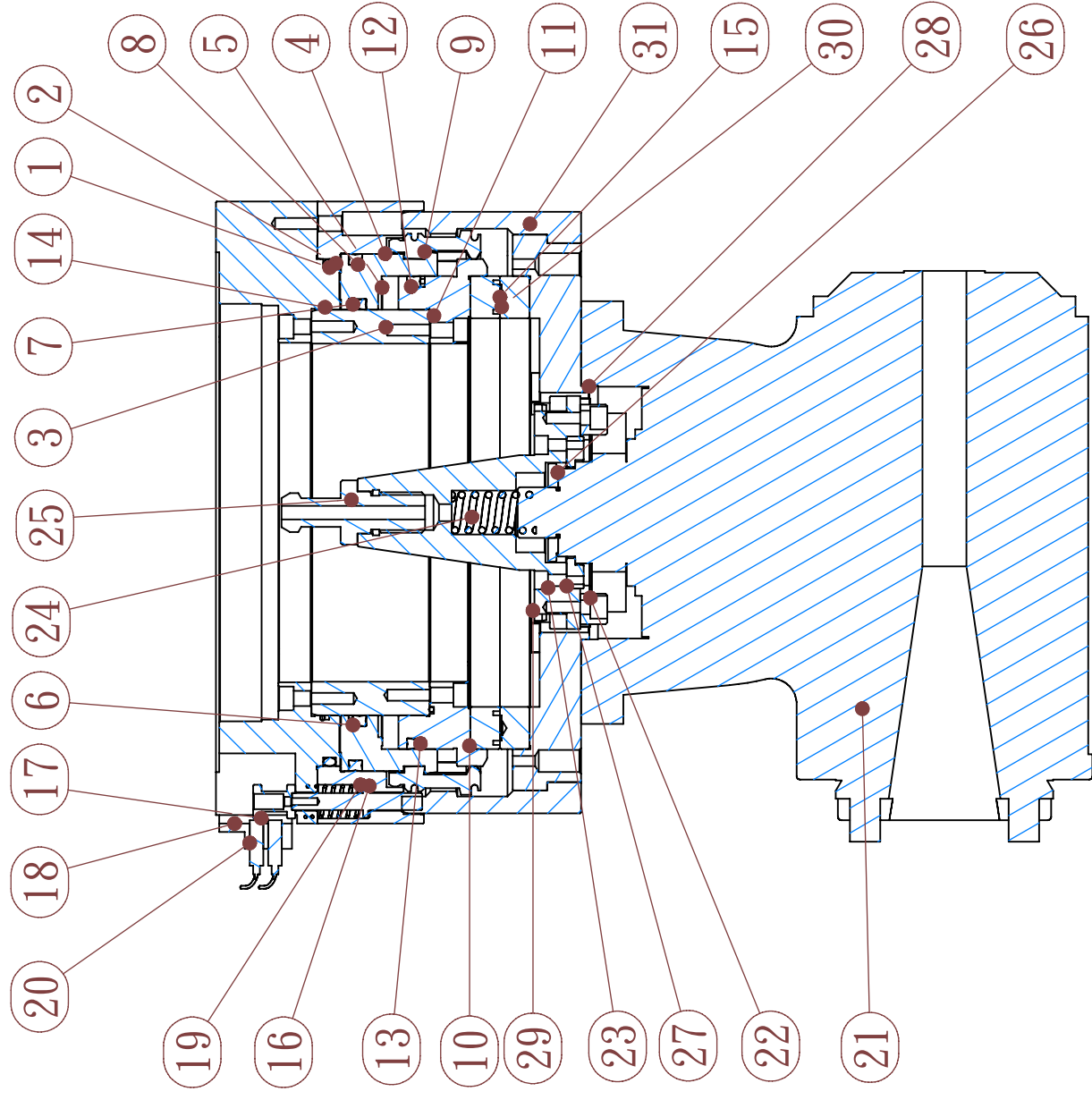

Part List					
Item	Part NO.	Parts Name	Parts Name	Specification	QTY
1	3603660B0	上連結座(臥頭)	CONDUIT BRACKET	SS41	1
2	4060020290	O型環	O RING	G290	1
3	3603642B0	油缸內環軸	CYLINDER BRACKET	S45C	1
4	3603661B0	油缸座	PISTON RINGS	S45C	1
5	3603607B0	活塞環	STAR-RING	SCM4	1
6	4060004448	星型環	BACK-UP RING	VITON	1
7	4060014448	背托環	STAR-RING	聚四氟乙烯	1
8	4060004452	星型環	STAR-RING	VITON	1
9	3603617B0	瓣爪	CLAW	SCM4	1
10	3603608B0	曲盤上固定座	UPPER RINGS	S45C	1
11	4060013230	O型環	O RING	NBR	1
12	4060004450	星型環	STAR-RING	VITON	1
13	4060014450	背托環	BACK-UP RING	聚四氟乙烯	1
14	4060013240	O型環	O RING	NBR	1
15	3603598A0	連結齒盤A(24T)	CHAINRING(A)	SCM440	1
16	3603615B0	上下偵測桿	DETECTION ROD	S45C	1
17	3603663A0	感應環	INDUCTION RING	S45C	1
18	3603664A0	近接開關座	PROXIMITY SWITCH BRACKET	SS41	1
19	4050119820	壓縮彈簧	COMPRESSIVE SPRING	SWP(琴鋼線)	1
20	4800013832	近接開關	PROXIMITY SWITCH	M8*32L(N.O./PNP/3000Hz)	2
21	3980100A0	手動90度臥頭	90°MILLING HEADSTOCK	功陽N75-4	1
22	4470800050	刀具固定鍵	KEY	SCM4	2
23	3603624B0	連結刀桿	SHAFT	SCM4	1
24	4050425050	壓縮彈簧	COMPRESSIVE SPRING	SWOSC-V	1
25	4340522050	拉桿螺栓	SCREW	MAS-50I	1
26	3603296B0	墊圈	WASHER	S45C	1
27	3603297B0	隔環	SPACER	S45C	1
28	3603623B0	臥頭連結板	HEADSTOCK CONNECTING BRACKET	FC30	1
29	3603611B0	擋塊	STOPPER	S45C	6
30	3603599A0	連結齒盤B(24T)	CHAINRING(B)	SCM440	1
31	3603609A0	臥頭連結環	ANGULAR HEAD LINK RING	S45C	1

Leaderway CNC Technologies Co., Ltd.

Scale	1:4	Drawing Name	90度臥頭單元 (90° MILLING ROTATING BRACKET UNIT)	Page	1
Drawn	卜珮云	Draw No.	2013/1/2	Draw No.	8120514A0 (2F89013)
Check	審核者				

A

B

C

D

E

F

A

B

C

D

E

F

1 2 3 4 5 6 7 8

1 2 3 4 5 6 7 8

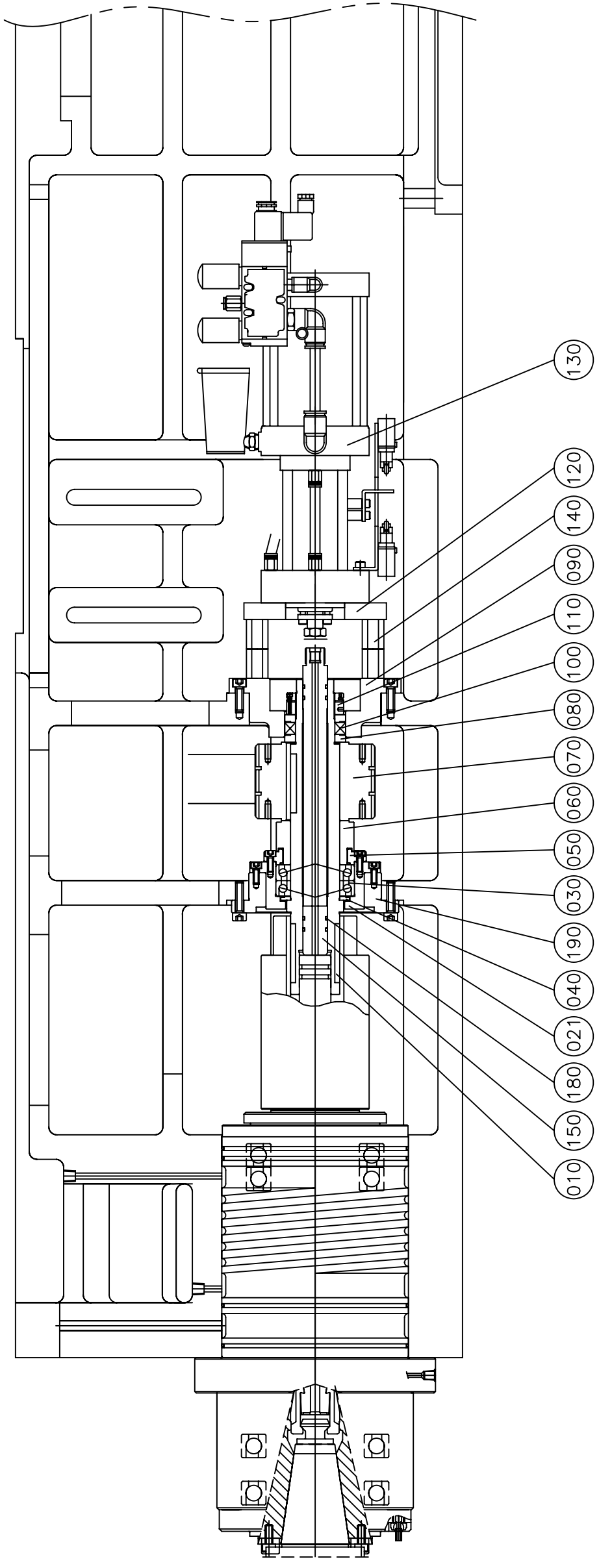

Leaderway Machinery Co. Ltd.

Scale	Drawing Name		Page
1:5	主軸打刀單元 (SPINDLE & BOOSTING CYLINDER UNIT)		1/1
	Drawn	Date	Draw No.
	Control	yy. mm. dd	
	Name		
	卜珉云		
	審核		

A3

*單階材料用量清單

製表日期: 102-12-10

第1頁

主件品號	序號	元件品號	品名 英文品名	規 格	用 量
2F27013			打刀單元 BOSSTING CYLINDER UNIT	LX-4225	
	0030	4400037010	斜角滾珠軸承 BEARING	NSK:7010CTYNSULP4	2
	0040	3600124B0	隔環 SPACER	3230\S45C	1
	0050	3600125A0	軸承壓蓋 BEARING CAP	3240\S45C	1
	0060	3600126B0	隔環 SPACER	3230\S45C	1
	0071	3971023B0	齒型皮帶輪(8YU-48T) PULLEY	3270\S45C	1
	0080	3600127B0	隔環 SPACER	3230\S45C	2
	0100	4400269083	深槽滾珠軸承 BEARING	NSK6908P6C3	1
	0110	4020401040	鎖緊螺帽 LOCK NUT	MK40(M40xP1.5)	1
	0120	3600130B0	上固定座 UPPER BRACKET	3180\SS41	1
	0130	3980025A0	打刀缸組件 TOOL RELEASE CYLINDER	9880\4Tx17L	1
	0140	3500426A0	六角型支撐桿 SUPPORTING ROD	3300\S45C	8
	0151	3603360A0	心軸(打刀) SHAFT	3290\S45C	1
	0160	4070161060	雙圓頭平行鍵 DOUBLE ROUND KEY	16x10x60L	1
	0170	4070120860	雙圓頭平行鍵 DOUBLE ROUND KEY	12x8x60L	2
	0180	4060010021	O型環 O RING	P-21	4
	0200	4180014140	直型高壓油管 HIGH-PRESSURE HOSE	1/4"R1x1400L	1
	0210	3603618A0	軸承座 BEARING HOUSING	3250\S45C	1
	0220	3603619A0	軸承座(下方) BEARING HOUSING	3250\S45C	1
	0230	3603620A0	連結軸座 SHAFT BRACKET	3230\S45C	1
	0241	3603621B0	傳動心軸(一) TRANSMISSION SHAFT(1)	4290\請改下3603621C0	1

<續下頁>

*單階材料用量清單

製表日期: 102-12-10

第2頁

主件品號	序號	元件品號	品名 英文品名	規 格	用 量

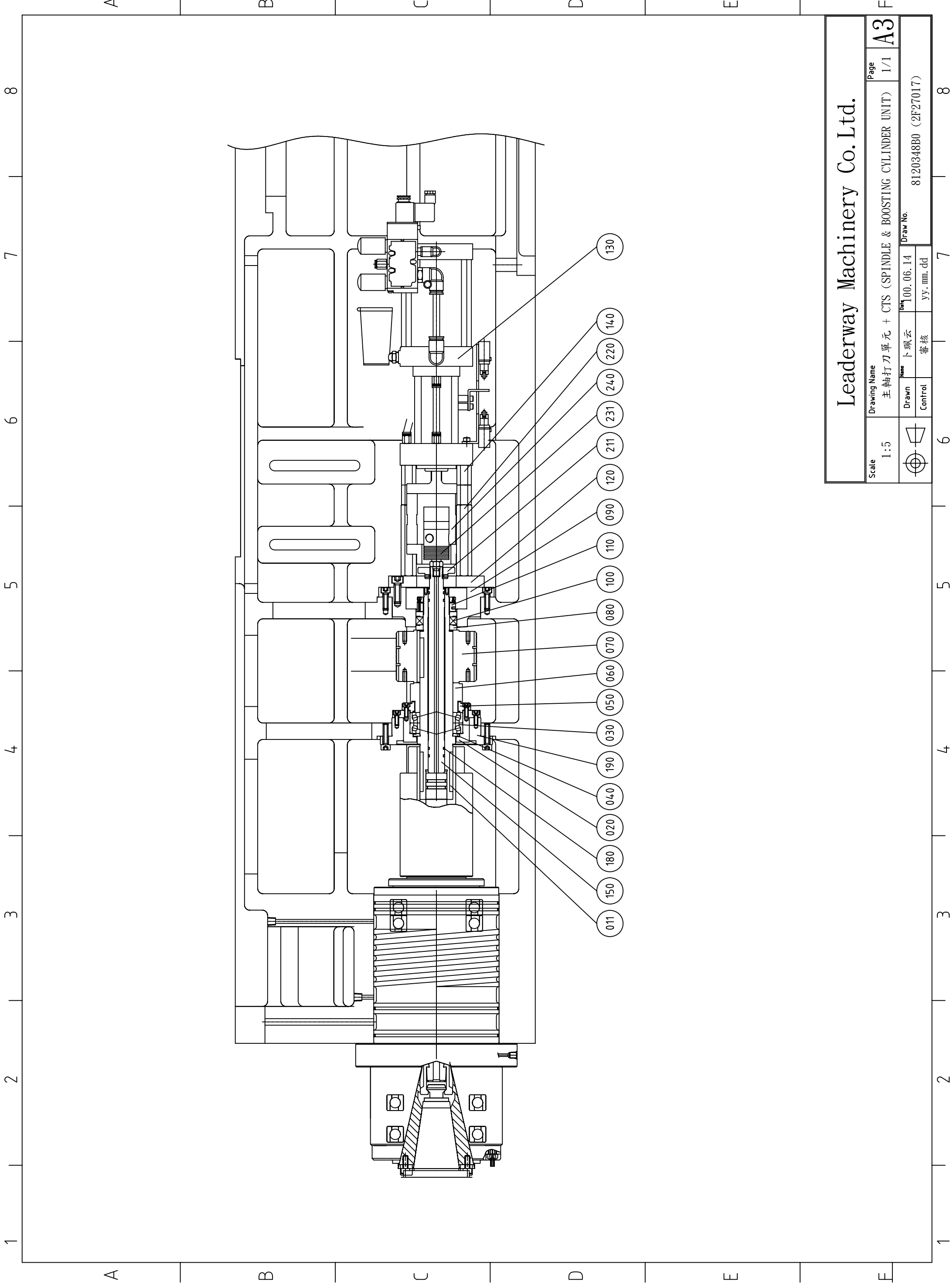

Leaderway Machinery Co. Ltd.

Scale	1:5	Drawing Name	主軸打刀單元 + CTS (SPINDLE & BOOSTING CYLINDER UNIT)		Page	1/1
		Drawn	卜珉云	Drawn No.	100.06.14	
		Control	審核	Draw No.	812034880 (2F27017)	

A3

8

7

6

5

4

3

2

1

A

B

C

D

E

F

*單階材料用量清單

製表日期: 102-01-03

第1頁

主件品號	序號	元件品號	品名 英文品名	規 格	用 量
2F27017			打刀單元 BOSSTING CYLINDER UNIT	LX-4225/CTS	
	0011	3603621B0	傳動心軸(一) TRANSMISSION SHAFT(1)	4290\SNCM21	1
	0030	4400037010	斜角滾珠軸承 BEARING	NSK:7010CTYNSULP4	2
	0040	3600124B0	隔環 SPACER	3230\S45C	1
	0050	3600125A0	軸承壓蓋 BEARING CAP	3240\S45C	1
	0060	3600126B0	隔環 SPACER	3230\S45C	1
	0070	3971023B0	齒型皮帶輪(8YU-48T) PULLEY	3270\S45C	1
	0080	3600127B0	隔環 SPACER	3230\S45C	2
	0100	4400269083	深槽滾珠軸承 BEARING	NSK6908P6C3	1
	0110	4020401040	鎖緊螺帽 LOCK NUT	MK40(M40xP1.5)	1
	0120	3600130B0	上固定座 UPPER BRACKET	3180\SS41	1
	0130	3980025A0	打刀缸組件 TOOL RELEASE CYLINDER	9880\4Tx17L	1
	0140	3500426A0	六角型支撐桿 SUPPORTING ROD	3300\S45C	8
	0150	3603360A0	心軸(打刀) SHAFT	3290\S45C	1
	0160	4070161060	雙圓頭平行鍵 DOUBLE ROUND KEY	16x10x60L	1
	0170	4070120860	雙圓頭平行鍵 DOUBLE ROUND KEY	12x8x60L	2
	0180	4060010021	O型環 O RING	P-21	4
	0211	3603361A0	打刀軸端蓋 TOP CAP,SHAFT	3230\S45C	1
	0220	3600025A0	支撐桿 SUPPORTING ROD	3300\六角鐵	4
	0231	4210720040	旋轉接頭 ROTARY JOINT	GU2000V(M10xP1.0)	1
	0240	4403000050	打刀缸連結座 BOOSTING CYLINDER BRACKET	BT50/CTS主軸	1

<續下頁>

*單階材料用量清單

製表日期: 102-01-03

第2頁

主件品號	序號	元件品號	品名 英文品名	規 格	用 量
2F27017	0250	4250200302	梭動閥(3口2位止回閥) CHECK VALVE	TXLT/3(CTS功能使用)	1
	0260	4180038570	直型高壓油管 HIGH-PRESSURE HOSE	3/8"R1x5700L	1
	0270	4180014140	直型高壓油管 HIGH-PRESSURE HOSE	1/4"R1x1400L	1
	0280	3603618A0	軸承座 BEARING HOUSING	3250\S45C	1
	0290	3603619A0	軸承座(下方) BEARING HOUSING	3250\S45C	1
	0300	3603620A0	連結軸座 SHAFT BRACKET	3230\S45C	1

<結 束>

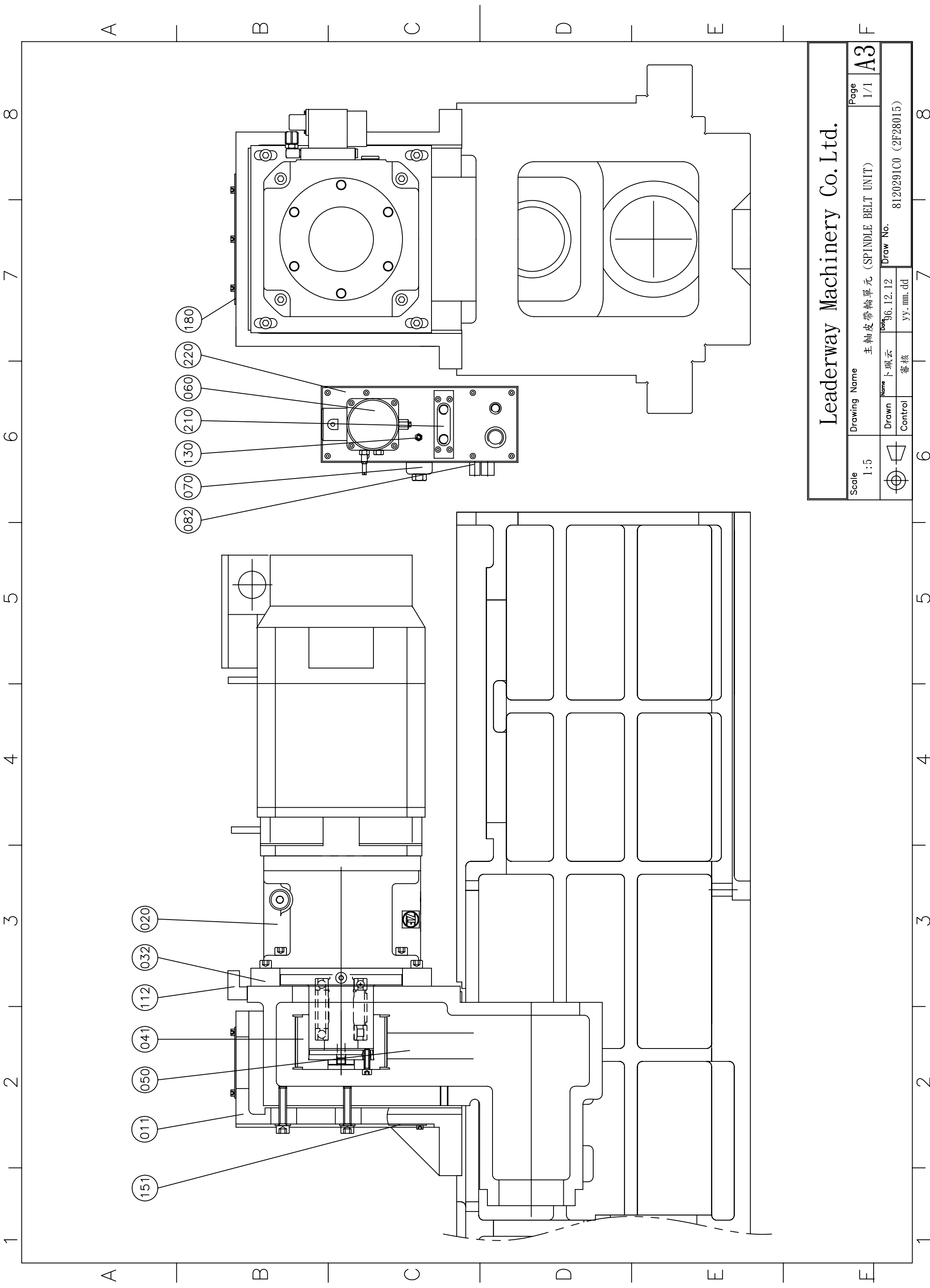

Leaderway Machinery Co. Ltd.

Scale	1:5	Drawing Name	主軸皮帶輪單元 (SPINDLE BELT UNIT)	Page	1/1
	Drawn	卜珉云	Date	96.12.12	Draw No. 8120291C0 (2F28015)
	Control	審核	yy. mm. dd		

*單階材料用量清單

製表日期: 102-12-10

第1頁

主件品號	序號	元件品號	品名 英文品名	規 格	用 量
2F28015			主軸皮帶輪單元(齒輪箱部份) SPINDLE BELT UNIT	LX-B/皮帶傳動	
	0011	3603472A0	馬達座 MOTOR BRACKET	1170\FC-30\3603472A2	1
	0020	3980029A0	ZF齒輪箱組件 GEAR BOX UNIT	9270\LDV-3220\8YU-56T	1
	0032	3603035C0	馬達調整板 ADJUSTABLE PLATE	3170\SS41	1
	0041	3971001B0	齒型皮帶輪(8YU-56T) PULLEY	3270\S45C	1
	0050	4600501040	齒型皮帶 PULLEY BELT	8YU-1040-50	1
	0060	4430412223	定積脫壓給油泵浦 LUBRICANT PUMP	MS-12W-220V三相-總高345	1
	0070	4510100001	油表 COOLANT LEVEL GAUGE	3''	1
	0082	3603017E0	冷卻油槽 OIL TANK	7520\SPCC	1
	0130	4800408508	浮動開關含接桿 FLOATING SWITCH	M8-P=1.25/85L	1
	0151	3603475A0	下蓋板 LOWER COVER	7180\SPCC	1
	0171	8150139C0	齒輪箱潤滑配管圖 GEAR BOX LUBRIFICATION DIAGRAM	LX-B\LX-4225	0
	0180	3603476A0	前蓋板 FRONT COVER	7180\SPCC	1
	0190	4510120001	塑膠油杯 OIL-TANK		1
	0200	4200601212	L型活動鐵接頭 90° ACTIVITIES CONNECTOR	1/2"PTx1/2"H活動	1
	0210	3603533A0	接管座 CONNECTING PIPE BRACKET	7210\SPCC	1
	0220	3603600A0	蓋板(油槽) OIL TROUGH COVER	7540\3603601A2\SPCC	1
	0230	3500010B0	調整檔塊 ADJUSTABLE STOPPER	3140\SS41	2

<結 束>

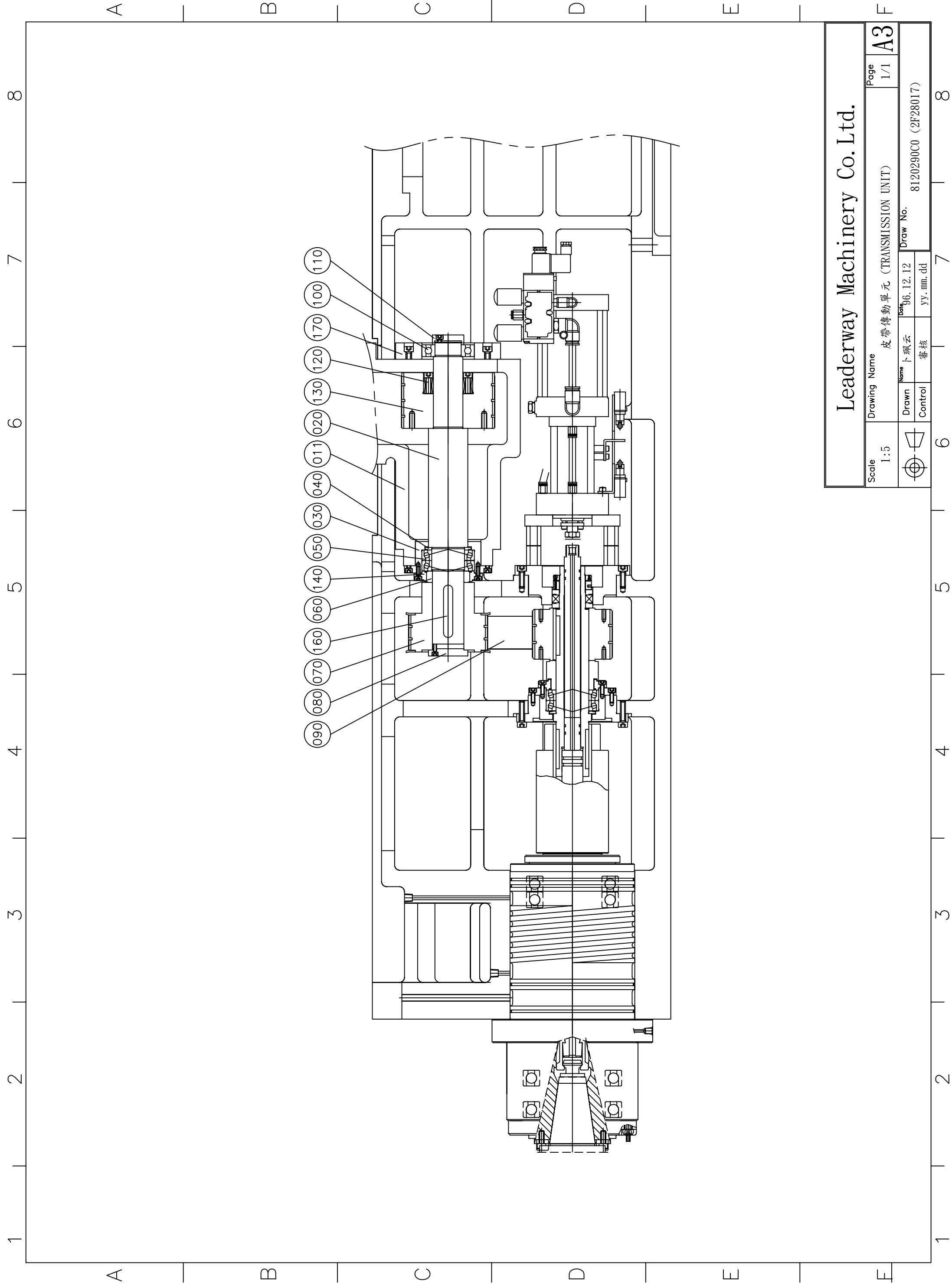

Leaderway Machinery Co. Ltd.

Scale	1:5	Drawing Name	皮帶傳動單元 (TRANSMISSION UNIT)	Page	1/1
		Drawn	卜珉云	Draw No.	8120290C0 (2F28017)
		Control	審核	Date	96.12.12 yy. mm. dd

F A3

1 2 3 4 5 6 7 8

A B C D E F

*單階材料用量清單

製表日期: 102-12-10

第1頁

主件品號	序號	元件品號	品名 英文品名	規 格	用 量
2F28017			主軸皮帶輪單元(中間軸部份) SPINDLE BELT UNIT	LX-B/皮帶傳動	
	0011	3603473A0	滑座(中間軸) ADJUSTABLE BRACKET	1160\FC-30\3603473A2	1
	0020	3603025B0	傳動心軸 TRANSMISSION SHAFT	3290\S45C	1
	0030	3600123D0	軸承座 BEARING HOUSING	3250\S45C	1
	0040	3600124B0	隔環 SPACER	3230\S45C	1
	0050	4400037010	斜角滾珠軸承 BEARING	NSK:7010CTYNSULP4	2
	0060	3603037B0	隔環 SPACER	3230\S45C	1
	0070	3560043A0	主軸馬達皮帶輪 PULLEY	3270\S45C\8YU-48T	1
	0080	3500020B0	馬達軸端蓋 SHAFT END COVER	3170\S45C	1
	0090	4600500760	齒型皮帶 PULLEY BELT	8YU-760-50	1
	0100	4400206208	深槽滾珠軸承 BEARING	6208ZZ 40*80*18	1
	0110	3603033A0	軸承壓蓋 BEARING CAP	3240\S45C	1
	0120	4061245075	迫緊環 PACKING RING		1
	0130	3971002B0	齒型皮帶輪(8YU-56T) PULLEY	3270\S45C	1
	0140	3600125A0	軸承壓蓋 BEARING CAP	3240\S45C	1
	0150	4070161060	雙圓頭平行鍵 DOUBLE ROUND KEY	16x10x60L	2
	0160	4070140980	雙圓頭平行鍵 DOUBLE ROUND KEY	14x9x80	1
	0170	3603474A0	上軸承座 BEARING HOUSING	3180\S41	1

<結 束>

A

B

C

D

E

F

1

2

3

4

5

6

7

8

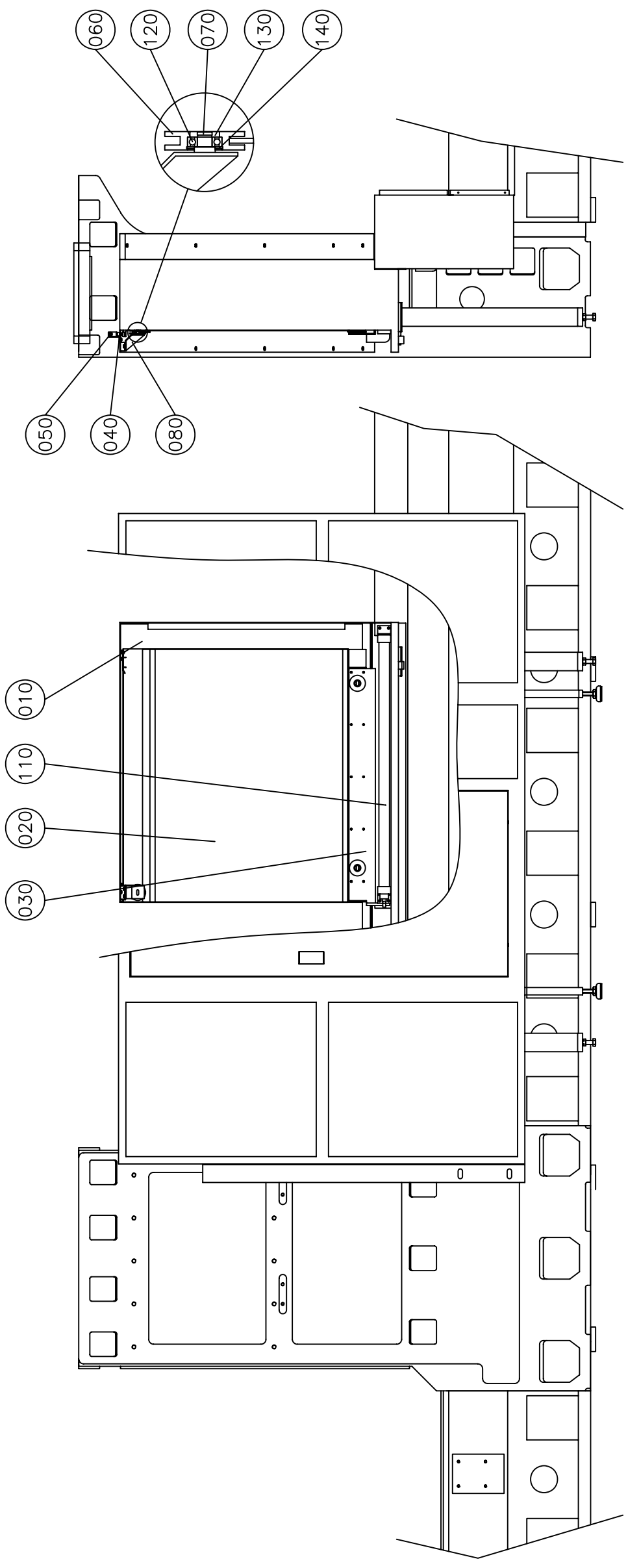

Leaderway Machinery Co. Ltd.

Scale 1:20	Drawing Name CHIP GUARD OF ATC UNIT (刀庫護罩單元) LX系列 #50-32T	Page 1/1
	Drawn 陳慶仁	Draw No. 8120369A0 (2F41009)
	Control 審核	

A3

1

2

3

4

5

6

7

8

*單階材料用量清單

製表日期: 102-12-10

第1頁

主件品號	序號	元件品號	品名 英文品名	規 格	用 量
2F41009			刀庫護罩單元 CHIP GUARD OF ATC UNIT	LX系列#50-32T\門柱(短)2084n	
	0010	3603517A0	刀庫護罩 TOOL MAGAZINE GUARD	7500\SPCC	1
	0020	3603518A0	刀庫門 TOOL MAGAZINE DOOR	7480\SPCC	1
	0030	3603519A0	刀庫門連結板 CONNECTING PLATE, TOOL MAGAZINE	7210\SPCC	1
	0041	3603122C0	微動開關座 SWITCH BRACKET	7160\SPCC	2
	0050	4800160947	微動開關 MICRO SWITCH	EN60947-5-1 1P67(SL1-A)	2
	0060	3603477A0	門輪 DOOR WHEEL	3260\S45C	3
	0070	3603478A0	門輪心軸 DOOR WHEEL SHAFT	3290\S45C	3
	0080	3603479A0	門輪座 DOOR WHEEL BRACKET	7110\SPCC	1
	0110	4500040950	氣壓缸 CYLINDER	MCQP-11-40-950-LB	1
	0150	4020402012	鎖緊螺帽 LOCK NUT	精車級(M12xP1.25)	1
	0160	3603503B0	刀庫外罩護欄組 TOOL MAGAZINE GUARD RAIL	SPCC	1
	0190	4650216100	防震腳墊(高低調整型) CUSHION PAD	TBK-16100	7

<結 束>

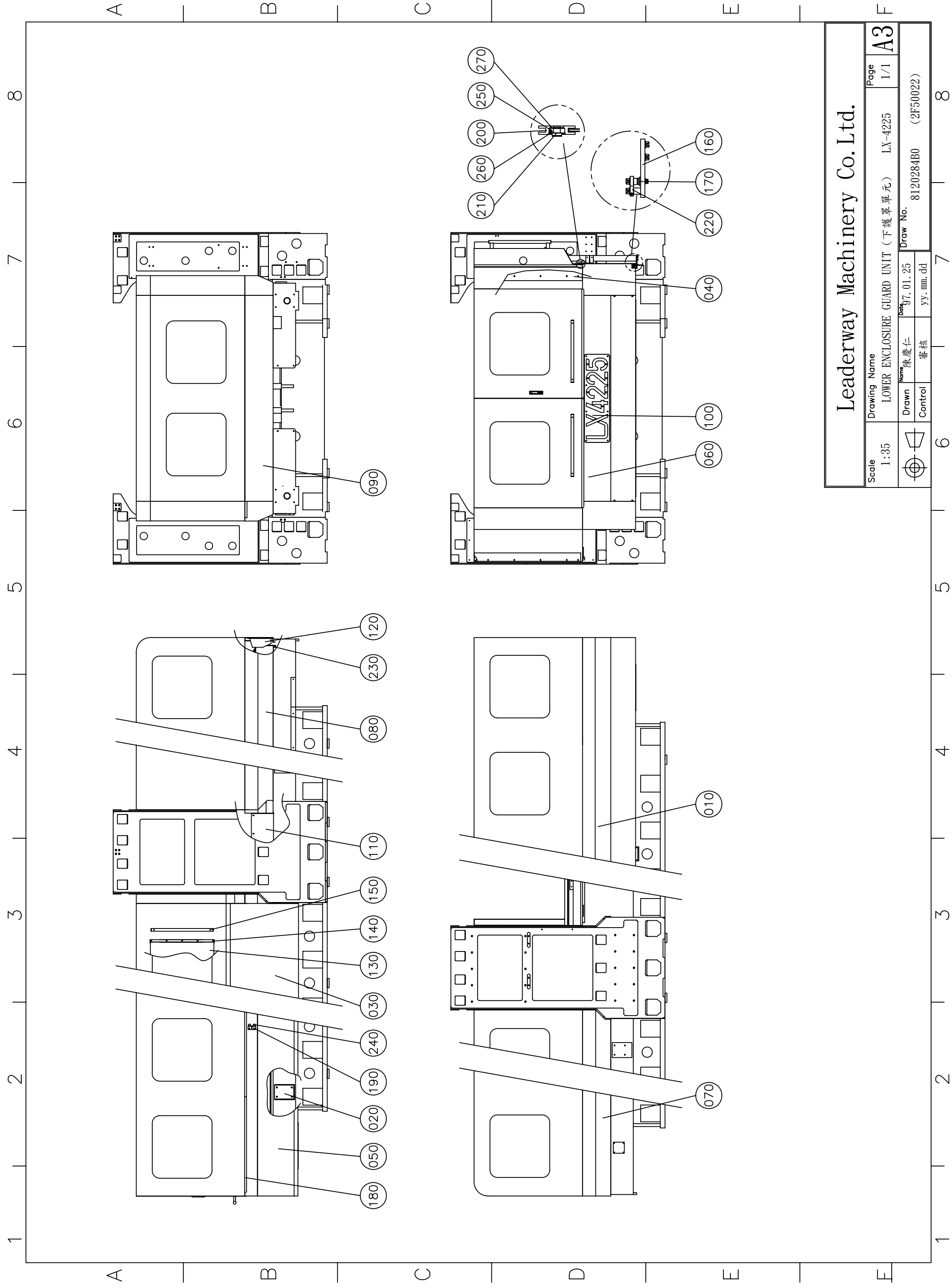

Leaderway Machinery Co. Ltd.			
Scale 1:35	Drawing Name LOWER ENCLOSURE GUARD UNIT (下護罩單元)	LX-4225	Page 1/1
	Drawn 陳慶仁	Date 97.01.25	Draw No. 8120284B0 (2F50022)
	Control 審核	yy. mm. dd	

*單階材料用量清單

製表日期: 102-12-10

第1頁

主件品號	序號	元件品號	品名 英文品名	規 格	用 量
2F50022			外型護罩單元 LOWER ENCLOSURE GUARD UNIT	LX-4225 下外罩	
	0011	3603157C0	左側前下罩 LEFT FRONT LOWER COVER	7500\SPCC	1
	0021	3603316B0	下罩連結座 LOWER GUARD BRACKET	7210\SPCC	9
	0033	3603527C0	右門 RIGHT DOOR	7480\SPCC	1
	0041	3603528B0	側門前罩 SIDE DOOR GUARD	7480\SPCC	1
	0052	3603155D0	右側前下罩 RIGHT FRONT LOWER COVER	7500\SPCC	1
	0061	3603376B0	前下罩 FRONT LOWER COVER	7500\SPCC	1
	0070	3603175B0	左側後下罩 LEFT REAR LOWER COVER	7500\SPCC	1
	0080	3603158B0	右側後下罩 RIGHT REAR LOWER COVER	7500\SPCC	1
	0092	3603377C0	後下罩 REAR LOWER COVER	7500\SPCC	1
	0100	3603496A0	前飾板(機型) FRONT PLATE	7180\SPCC	1
	0110	3603326A0	立柱內側下板 COLUMN LOWER COVER	7210\SPCC\LX4225\3225\3220	2
	0121	3603184C0	後下罩飾板 REAR LOWER COVER PLATE	7500\SPCC	1
	0130	3603178A0	壓克力窗 ACRYLIC PLATE	4360\ACRY	1
	0140	3603179C0	門窗壓板 WINDOW PUSHING PAD	7120\請改下3603179D0	4
	0150	4300400600	管型把手(自然色) HAHDLE	U1-600L	2
	0160	3603488A0	滾輪固定座 ROLLER BRACKET	7180\SPCC	2
	0170	3603489A0	滾輪座 ROLLER BRACKET	7180\SPCC	4
	0180	3603490A0	側窗飾條 RUBBER RIBBON	5510\SUS303	5
	0190	3603491A0	側門防撞座 RUBBER CUSHION BRACKET	7210\SPCC	1
	0200	3603477A0	門輪 DOOR WHEEL	3260\S45C	2

<續下頁>

*單階材料用量清單

製表日期: 102-12-10

第2頁

主件品號	序號	元件品號	品名 英文品名	規 格	用 量
2F50022	0210	3603478A0	門輪心軸 DOOR WHEEL SHAFT	3290\S45C	2
	0220	4402000628	軸承 BEARING	628ZZ 8*24*8 日本	8
	0230	3603119A0	摺動罩後蓋板 TELESCOPIC COVER REAR COVER	7510\SPCC	1
	0240	3540246A0	防撞膠(前門) RUBBER CUSHION	4370\請改下3540246B0	2
	0260	4060600028	C型扣環(孔用) C TYPE RETAINER RING	R-28	2
	0270	4060700012	C型扣環(軸用) C TYPE RETAINER RING	S-12	2

1 2 3 4 5 6 7 8

A A B C D E F

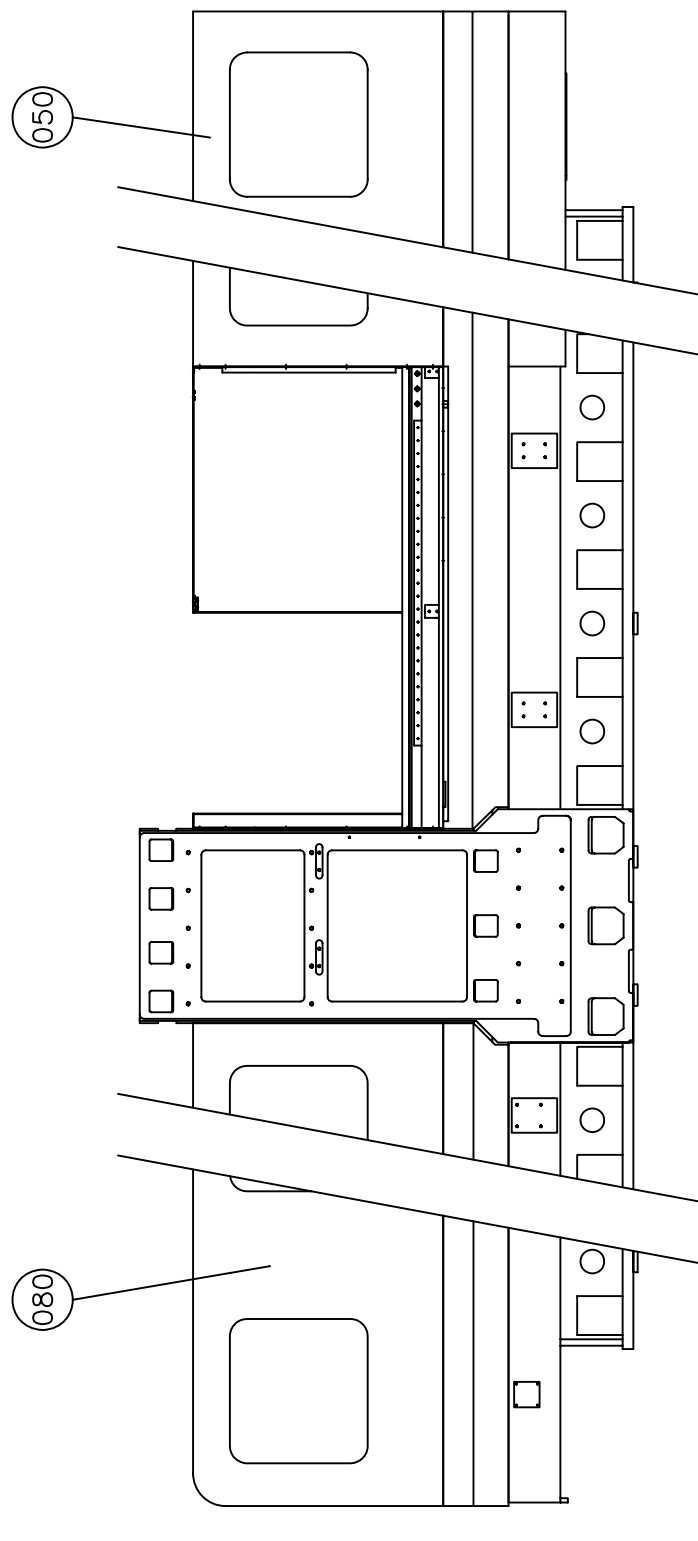
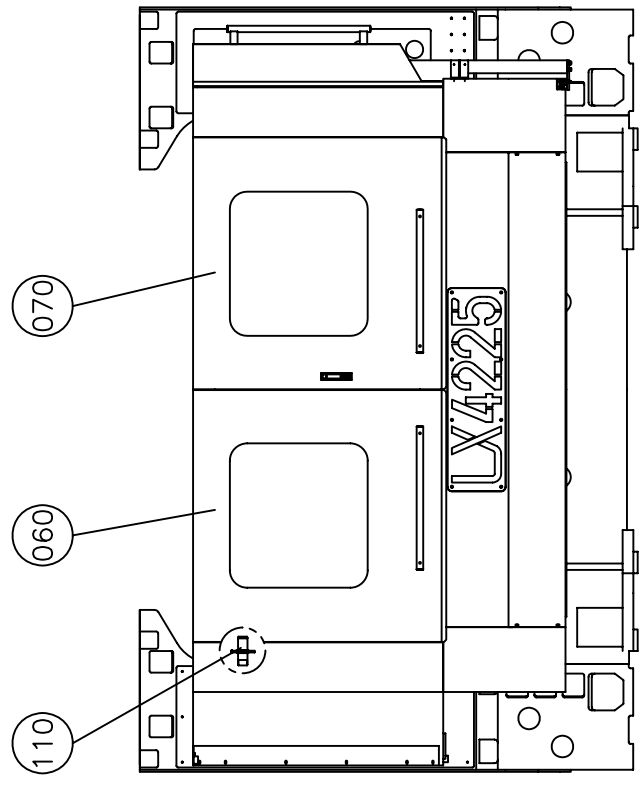
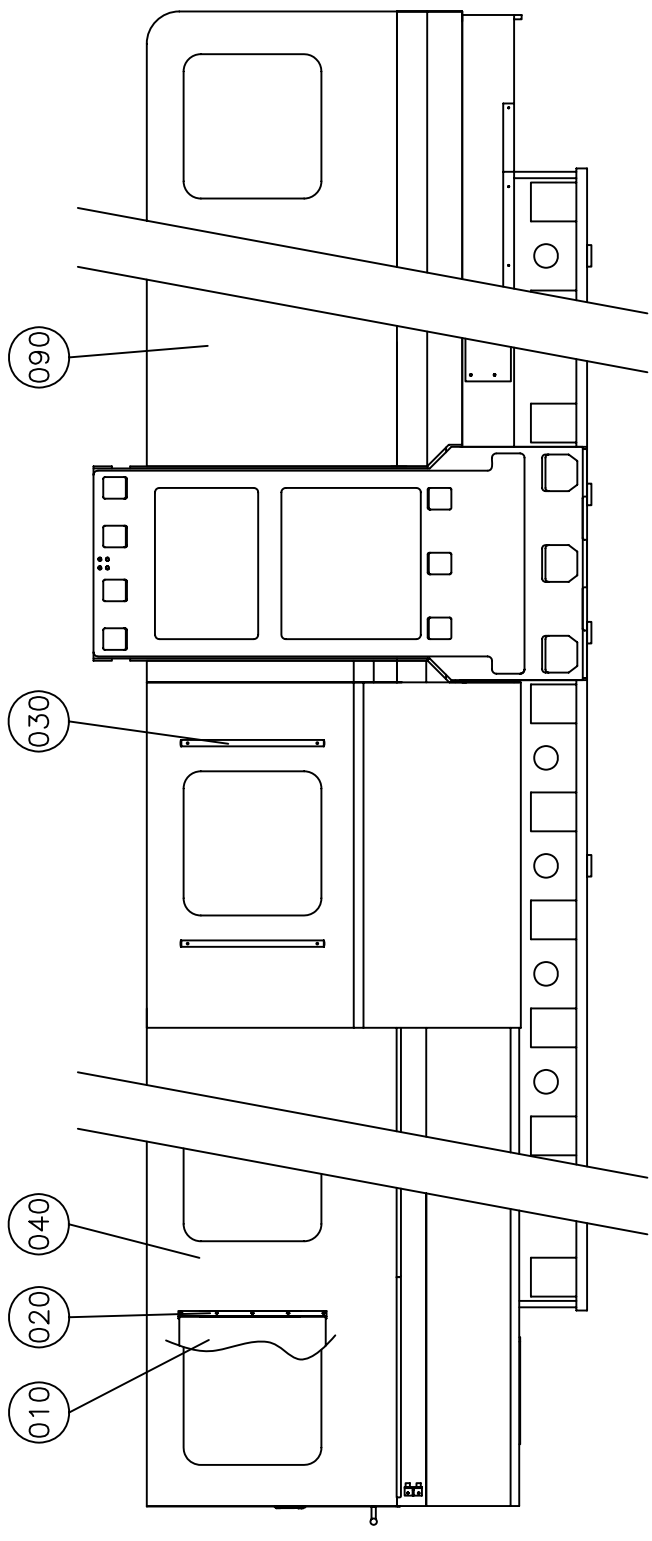
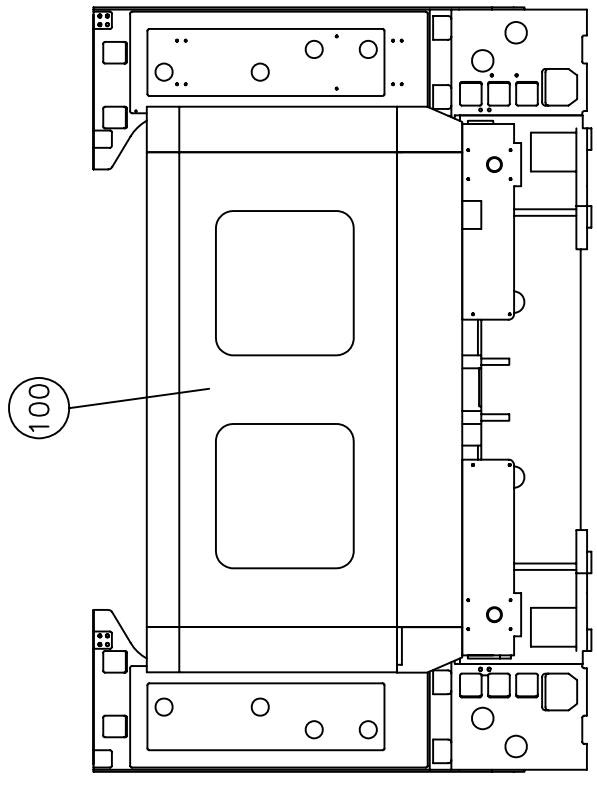

Leaderway Machinery Co. Ltd.			
Scale	Drawing Name	Page	
1:35	UPPER ENCLOSURE GUARD UNIT (上護罩單元) LX-4225	1/1	A3
	Drawn	Date	Draw No.
	陳慶仁	97.01.25	
	Control	審核	
		yy. mm. dd	

1 2 3 4 5 6 7 8

*單階材料用量清單

製表日期: 102-12-10

第1頁

主件品號	序號	元件品號	品名 英文品名	規 格	用 量
2F50023			外型護罩單元 UPPER ENCLOSURE GUARD UNIT	LX-4225 上外罩	
	0030	4300400600	管型把手(自然色) HANDLE	U1-600L	2
	0043	3603183E0	右側前側罩 RIGHT FRONT SIDE GUARD	7500\SPCC	1
	0053	3603169E0	左側前側罩 LEFT FRONT SIDE GUARD	7500\SPCC	1
	0062	3603416C0	左前門 (L) FRONT DOOR	7480\SPCC	1
	0073	3603415D0	右前門 (R) FRONT DOOR	7480\SPCC	1
	0083	3603171E0	左側後側罩 LEFT FRONT SIDE GUARD	7500\SPCC	1
	0093	3603172E0	右側後側罩 RIGHT REAR SIDE GUARD	7500\SPCC	1
	0102	3603413C0	後護罩 REAR GUARD	7500\SPCC	1
	0110	3603348A0	門旋軸座 DOOR HANDLE	7210\SPCC	4

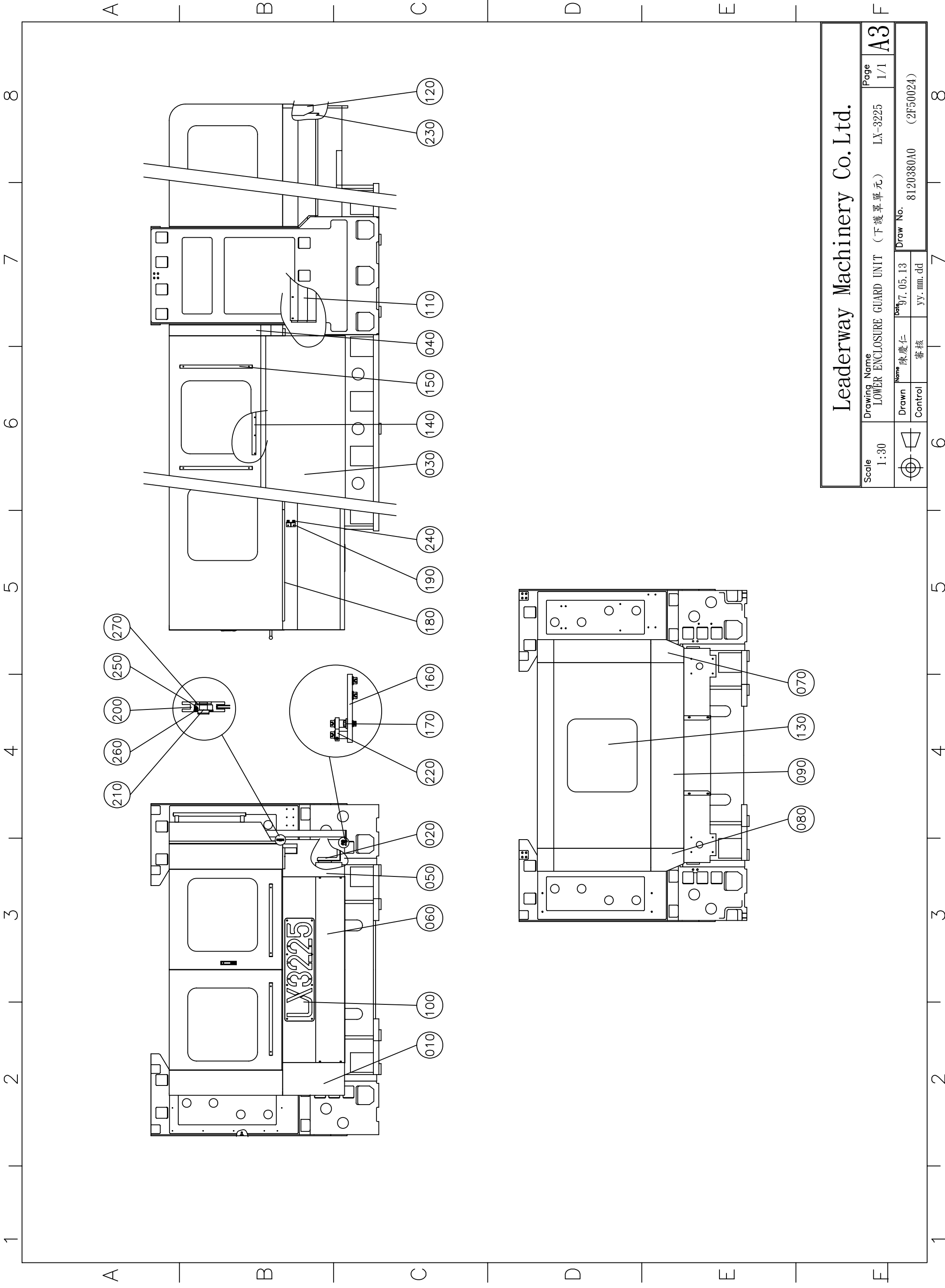

Leaderway Machinery Co. Ltd.

Scale 1:30	Drawing Name LOWER ENCLOSURE GUARD UNIT (下護罩單元)	LX-3225	Page 1/1
	Drawn Control	Name 陳慶仁 審核	Draw No. 8120380A0 (2F50024)
	Date 97.05.13 yy. mm. dd		

*單階材料用量清單

製表日期: 102-12-10

第1頁

主件品號	序號	元件品號	品名 英文品名	規 格	用 量
2F50024			外型護罩單元 LOWER ENCLOSURE GUARD UNIT	LX-3225 下外罩	
	0012	3603315D0	左前下罩 LEFT FRONT LOWER COVER	7500\SPCC	1
	0021	3603316B0	下罩連結座 LOWER GUARD BRACKET	7210\SPCC	7
	0033	3603527C0	右門 RIGHT DOOR	7480\SPCC	1
	0041	3603528B0	側門前罩 SIDE DOOR GUARD	7480\SPCC	1
	0052	3603320D0	右前下罩 RIGHT FRONT LOWER COVER	7500\SPCC	1
	0061	3603376B0	前下罩 FRONT LOWER COVER	7500\SPCC	1
	0070	3603322B0	左後下罩 LEFT REAR LOWER COVER	7500\SPCC	1
	0080	3603323B0	右後下罩 RIGHT REAR LOWER COVER	7500\SPCC	1
	0092	3603377C0	後下罩 REAR LOWER COVER	7500\SPCC	1
	0100	3603378A0	前飾板(機型) REAR LOWER COVER	7180\SPCC	1
	0110	3603326A0	立柱內側下板 COLUMN LOWER COVER	7210\SPCC\LX4225\3225\3220	2
	0121	3603184C0	後下罩飾板 REAR LOWER COVER PLATE	7500\SPCC	1
	0130	3603178A0	壓克力窗 ACRYLIC PLATE	4360\ACRY	1
	0141	3603179D0	門窗壓板 WINDOW PUSHING PAD	7120\SPCC	4
	0150	4300400600	管型把手(自然色) HAHDLE	U1-600L	2
	0160	3603488A0	滾輪固定座 ROLLER BRACKET	7180\SPCC	2
	0170	3603489A0	滾輪座 ROLLER BRACKET	7180\SPCC	4
	0180	3603490A0	側窗飾條 RUBBER RIBBON	5510\SUS303	4
	0190	3603491A0	側門防撞座 RUBBER CUSHION BRACKET	7210\SPCC	1
	0200	3603477A0	門輪 DOOR WHEEL	3260\S45C	2

<續下頁>

*單階材料用量清單

製表日期: 102-12-10

第2頁

主件品號	序號	元件品號	品名 英文品名	規 格	用 量
2F50024	0210	3603478A0	門輪心軸 DOOR WHEEL SHAFT	3290\S45C	2
	0220	4402000628	軸承 BEARING	628ZZ 8*24*8 日本	8
	0230	3603119A0	摺動罩後蓋板 TELESCOPIC COVER REAR COVER	7510\SPCC	1
	0240	3540246A0	防撞膠(前門) RUBBER CUSHION	4370\請改下3540246B0	2
	0260	4060600028	C型扣環(孔用) C TYPE RETAINER RING	R-28	2
	0270	4060700012	C型扣環(軸用) C TYPE RETAINER RING	S-12	2

1 2 3 4 5 6 7 8

A B C D E F

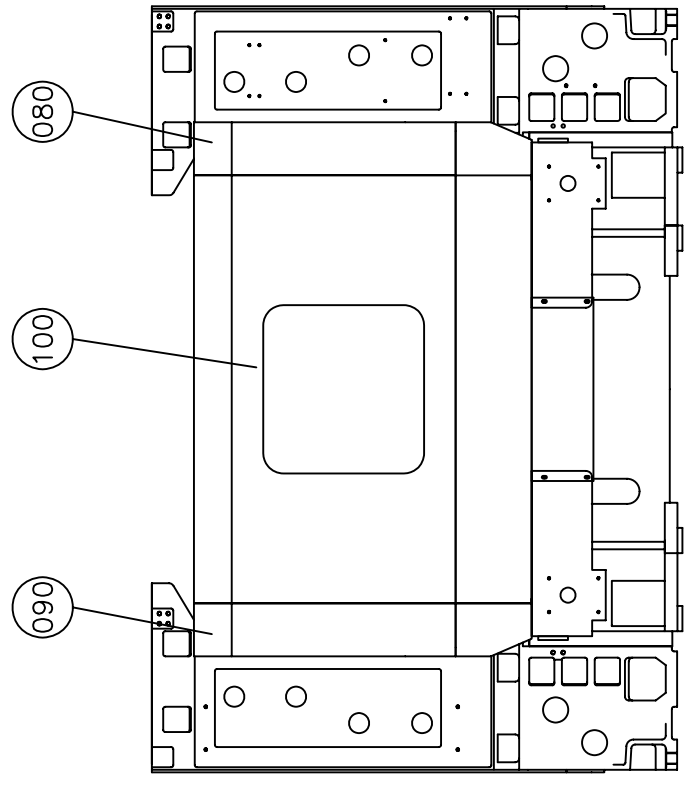
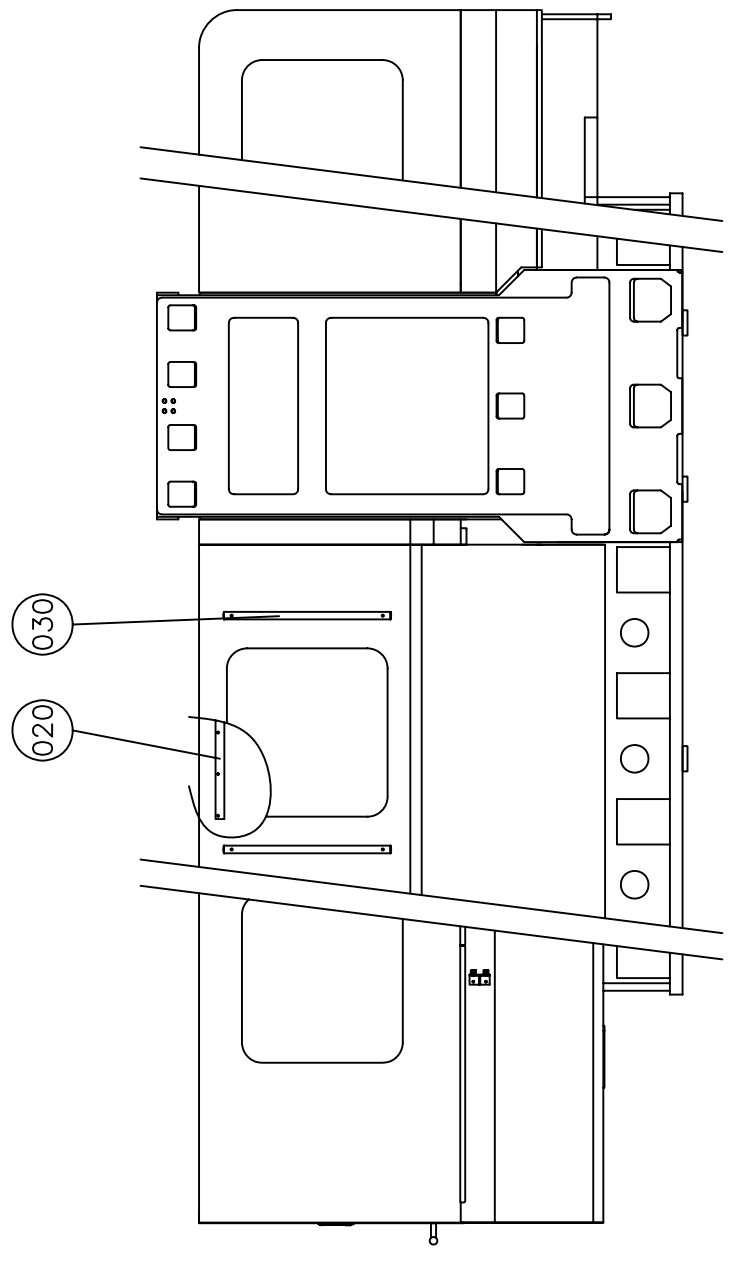
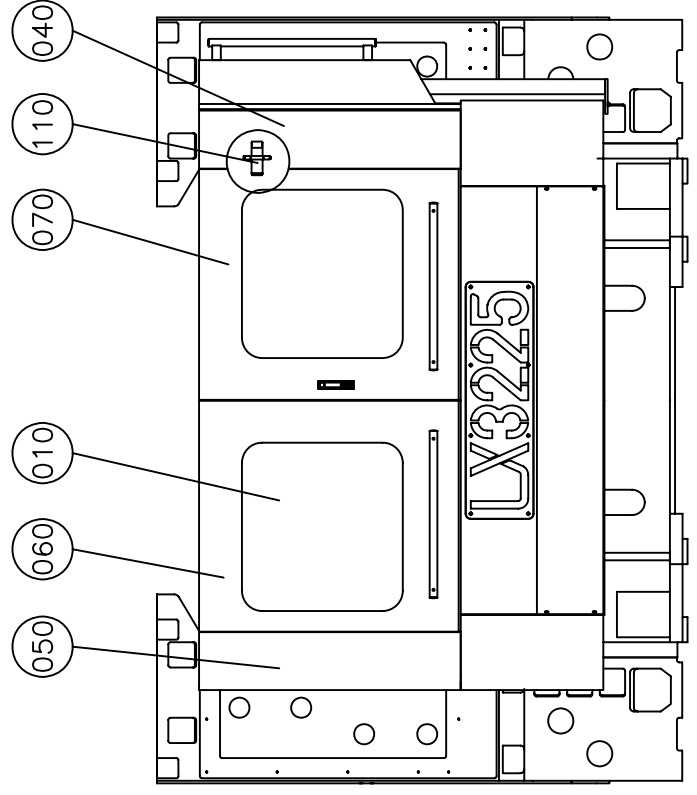

Leaderway Machinery Co. Ltd.

Scale 1:30	Drawing Name UPPER ENCLOSURE GUARD UNIT (上護罩單元)	Page 1/1
	Drawn Control	LX-3225 (2F50025)
	Name 陳慶仁 審核	

Date 97.05.12	8
yy. mm. dd	7

1 2 3 4 5 6 7 8

*單階材料用量清單

製表日期: 102-12-10

第1頁

主件品號	序號	元件品號	品名 英文品名	規 格	用 量
2F50025			外型護罩單元 UPPER ENCLOSURE GUARD UNIT	LX-3225 上外罩	
	0030	4300400600	管型把手(自然色) HAHDLE	U1-600L	2
	0043	3603520B0	右前側罩 RIGHT FRONT SIDE GUARD	7500\SPCC	1
	0053	3603521B0	左前側罩 LEFT FRONT SIDE GUARD	7500\SPCC	1
	0062	3603416C0	左前門 (L) FRONT DOOR	7480\SPCC	1
	0073	3603415D0	右前門 (R) FRONT DOOR	7480\SPCC	1
	0083	3603524B0	左後側罩 LEFT REAR SIDE GUARD	7500\SPCC	1
	0093	3603525B0	右後側罩 RIGHT REAR SIDE GUARD	7500\SPCC	1
	0102	3603413C0	後護罩 REAR GUARD	7500\SPCC	1
	0110	3603348A0	門旋軸座 DOOR HANDLE	7210\SPCC	4

<結 束>

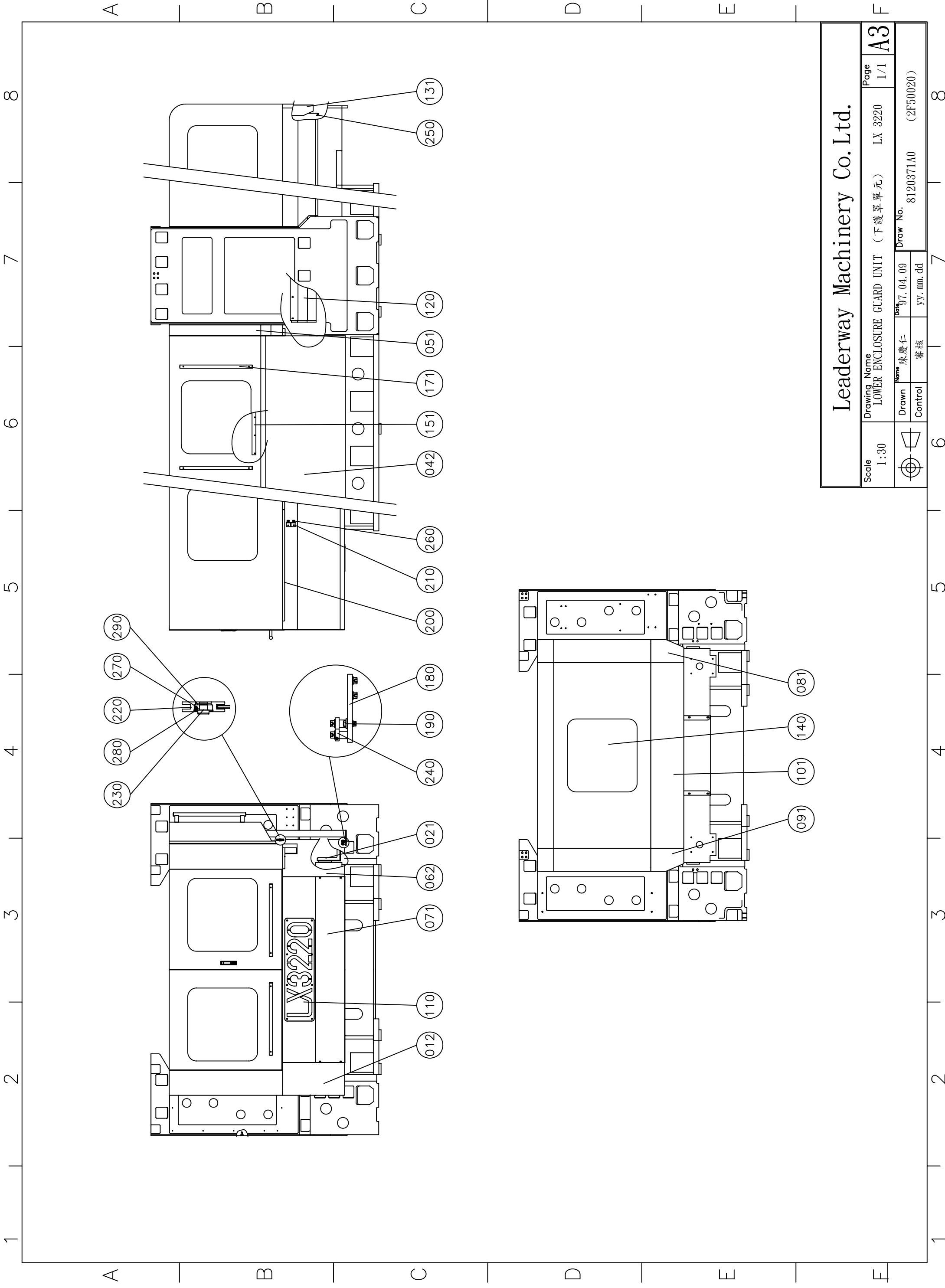

Leaderway Machinery Co. Ltd.

Scale 1:30	Drawing Name LOWER ENCLOSURE GUARD UNIT (下護罩單元)	LX-3220	Page 1/1
	Drawn Control	Drawn Name 陳慶仁 審核	Draw No. 8120371A0 (2F50020)
	Date 97.04.09 yy. mm. dd		

*單階材料用量清單

製表日期: 102-12-10

第1頁

主件品號	序號	元件品號	品名 英文品名	規 格	用 量
2F50020			外型護罩單元 ENCLOSURE GUARD UNIT	LX-3220/門柱(高)2284mm/下半	
	0013	3603315D0	左前下罩 LEFT FRONT LOWER COVER	7500\SPCC	1
	0021	3603316B0	下罩連結座 LOWER GUARD BRACKET	7210\SPCC	7
	0042	3603177D0	右門 RIGHT DOOR	7480\SPCC	1
	0051	3603487A0	側門前罩 SIDE DOOR GUARD	7480\SPCC	1
	0063	3603320D0	右前下罩 RIGHT FRONT LOWER COVER	7500\SPCC	1
	0071	3603366A0	前下罩 FRONT LOWER COVER	7500\請改下3603366B0	1
	0081	3603322B0	左後下罩 LEFT REAR LOWER COVER	7500\SPCC	1
	0091	3603323B0	右後下罩 RIGHT REAR LOWER COVER	7500\SPCC	1
	0101	3603324B0	後下罩 REAR LOWER COVER	7500\SPCC	1
	0110	3603325A0	前飾板(機型) FRONT PLATE	7180\SPCC	1
	0120	3603326A0	立柱內側下板 COLUMN LOWER COVER	7210\SPCC\LX4225\3225\3220	2
	0132	3603327C0	後下罩內飾板 LOWER INNER COVER	7210\SPCC	1
	0140	3603178A0	壓克力窗 ACRYLIC PLATE	4360\ACRY	1
	0151	3603179C0	門窗壓板 WINDOW PUSHING PAD	7120\請改下3603179D0	4
	0171	4300400600	管型把手(自然色) HAHDLE	U1-600L	2
	0180	3603488A0	滾輪固定座 ROLLER BRACKET	7180\SPCC	2
	0190	3603489A0	滾輪座 ROLLER BRACKET	7180\SPCC	4
	0200	3603490A0	側窗飾條 RUBBER RIBBON	5510\SUS303	4
	0210	3603491A0	側門防撞座 RUBBER CUSHION BRACKET	7210\SPCC	1
	0220	3603477A0	門輪 DOOR WHEEL	3260\S45C	2

<續下頁>

*單階材料用量清單

製表日期: 102-12-10

第2頁

主件品號	序號	元件品號	品名 英文品名	規 格	用 量
2F50020	0230	3603478A0	門輪心軸 DOOR WHEEL SHAFT	3290\S45C	2
	0240	4402000628	軸承 BEARING	628ZZ 8*24*8 日本	8
	0250	3603268B0	摺動罩後蓋板 TELESCOPIC COVER REAR COVER	7210\SPCC	1
	0260	3540246A0	防撞膠(前門) RUBBER CUSHION	4370\請改下3540246B0	2
	0270	4400206001	深槽滾珠軸承 BEARING	6001ZZ 12x28x8	2
	0280	4060600028	C型扣環(孔用) C TYPE RETAINER RING	R-28	2
	0290	4060700012	C型扣環(軸用) C TYPE RETAINER RING	S-12	2

<結 束>

1 2 3 4 5 6 7 8

A B C D E F

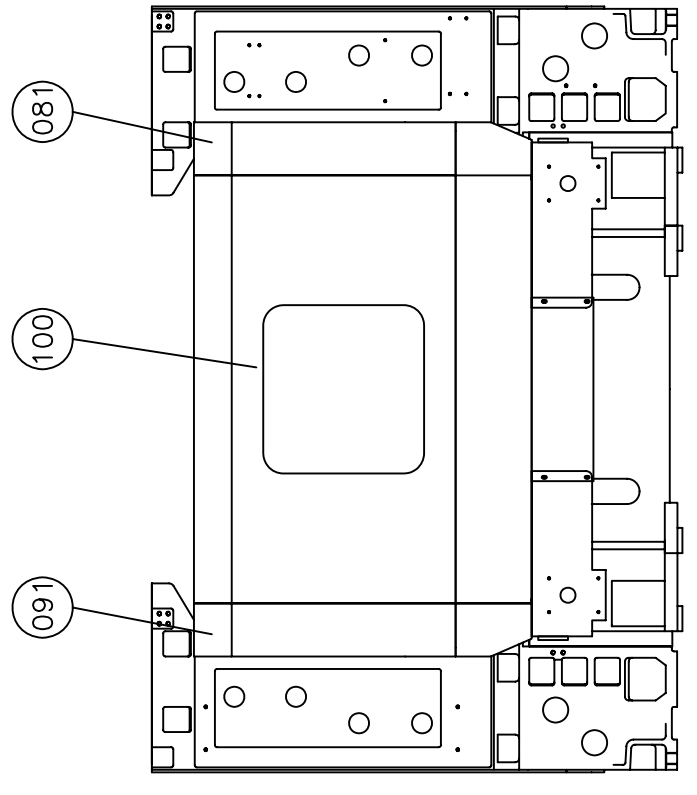
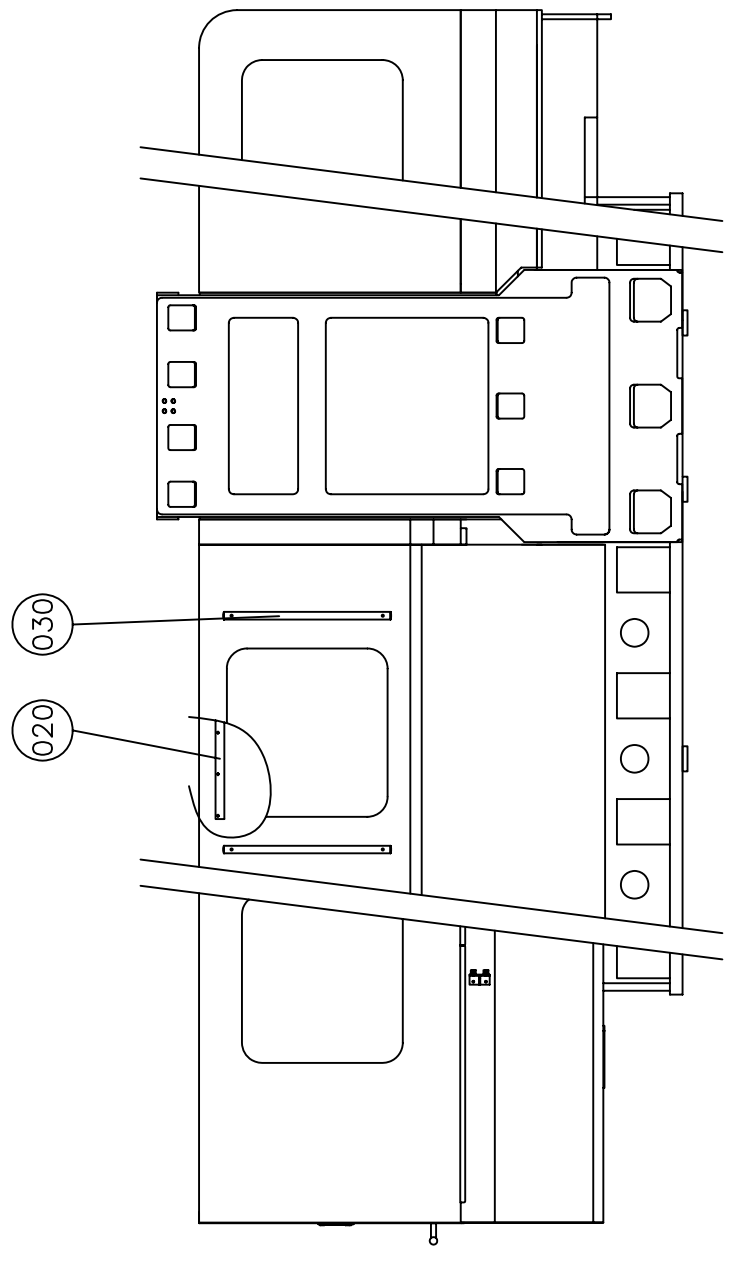
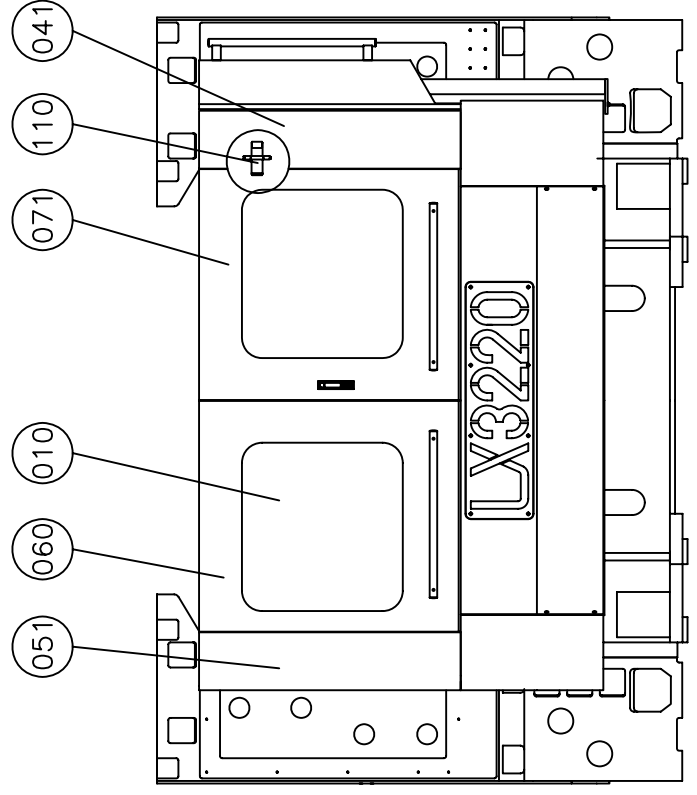

Leaderway Machinery Co. Ltd.			
Scale 1:30	Drawing Name UPPER ENCLOSURE GUARD UNIT (上護罩單元)	LX-3220	Page 1/1
	Drawn Control	Name 陳慶仁 審核	Date 97.04.09
	Draw No. 8120372A0 (2F50026)		

1 2 3 4 5 6 7 8

*單階材料用量清單

製表日期: 102-12-10

第1頁

主件品號	序號	元件品號	品名 英文品名	規 格	用 量
2F50026			外型護罩單元 UPPER ENCLOSURE GUARD UNIT	LX-3220/門柱(高)2284mm/上外	
	0010	3603178A0	壓克力窗 ACRYLIC PLATE	4360\ACRY	11
	0020	3603179C0	門窗壓板 WINDOW PUSHING PAD	7120\請改下3603179D0	44
	0030	4300400600	管型把手(自然色) HAHDLE	U1-600L	2
	0042	3603342C0	右前側罩 RIGHT FRONT SIDE GUARD	7500\SPCC	1
	0052	3603343C0	左前側罩 LEFT FRONT SIDE GUARD	7500\SPCC	1
	0060	3603349A0	左前門 (L) FRONT DOOR	7480\SPCC	1
	0071	3603347B0	右前門 (R) FRONT DOOR	7480\SPCC	1
	0081	3603344B0	左後側罩 LEFT REAR SIDE GUARD	7500\SPCC	1
	0091	3603345B0	右後側罩 RIGHT REAR SIDE GUARD	7500\SPCC	1
	0100	3603346B0	後護罩 REAR GUARD	7500\SPCC	1
	0110	3603348A0	門旋軸座 DOOR HANDLE	7210\SPCC	4

<結 束>

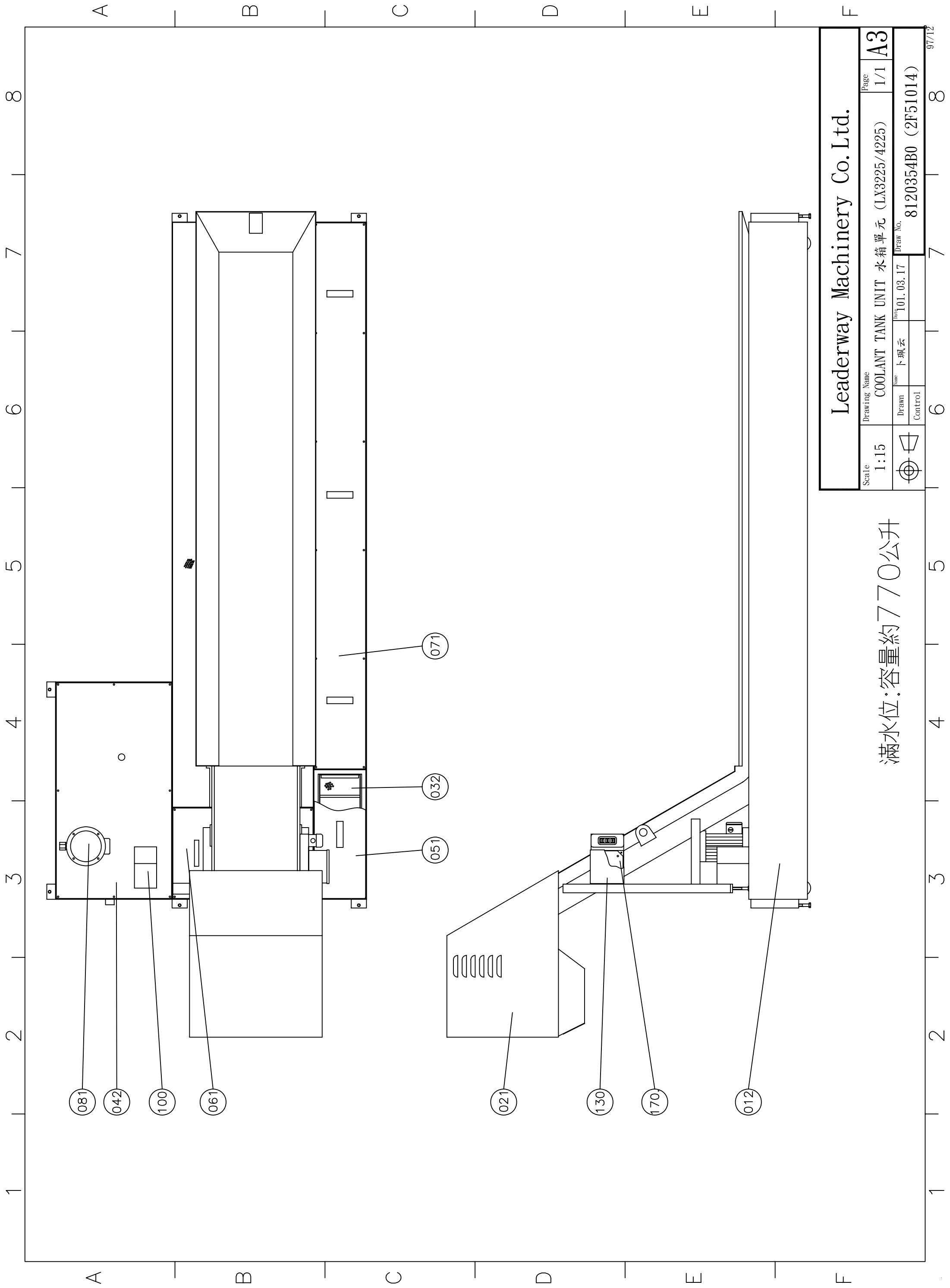

Leaderway Machinery Co. Ltd.

Scale	1:15	Drawing Name	COOLANT TANK UNIT 水箱單元 (LX3225/4225)	Page	1/1
		Drawn	卜珮云	Draw No.	8120354B0 (2F51014)
		Control			

滿水位:容量約770公升

*單階材料用量清單

製表日期: 102-01-03

第1頁

主件品號	序號	元件品號	品名 英文品名	規 格	用 量
2F51014			水箱單元(含螺旋排屑) COOLANT TANK UNIT(COIL TYPE CO	LX-4225/LX-3225 容量約770公	
	0012	3603404B0	水箱 COOLANT TANK	7580\SPCC	1
	0021	3603147B0	排屑機 CHIP CONVEYOR	9940	1
	0032	3603398A0	蓄屑槽 FILTER NET	7590\網板	1
	0042	3603406C0	泵浦固定板 PUMP BRACKET	7180\SPCC	1
	0051	3603399A0	蓄屑槽蓋 FILTER NET COVER	7550\SPCC	1
	0061	3603407B0	水箱蓋(一) COOLANT TANK COVER(1)	7510\SPCC	1
	0071	3603152B0	水箱蓋(二) COOLANT TANK COVER(2)	7510\SPCC	1
	0081	4430040503	切削液泵浦(直立式) COOLANT PUMP	TPHK4T5-3	1
	0090	4510100001	油表 COOLANT LEVEL GAUGE	3''	1
	0100	4520900800	油水分離機 OIL WATER SEPARATOR	HD-800\皮帶長度為620長	1
	0110	3560442B0	蓄油桶 OIL REVIO	7580\SPCC	1
	0130	3540113B0	電氣盒蓋 TERMINAL BOX COVER	7210\SPCC	1
	0140	4180012900	直型高壓油管 HIGH-PRESSURE HOSE	1/2"R1x9000L	1
	0150	4180012570	直型高壓油管 HIGH-PRESSURE HOSE	1/2"R1x5700L	1
	0161	4180012600	直型高壓油管 HIGH-PRESSURE HOSE	1/2"R1x6000L	1
	0170	3603589A0	電氣盒(排屑機) TERMINAL BOX	7210\SPCC	1
	0180	3603793A0	蓄屑車(可倒式)	7520\市購品	1

<結 束>

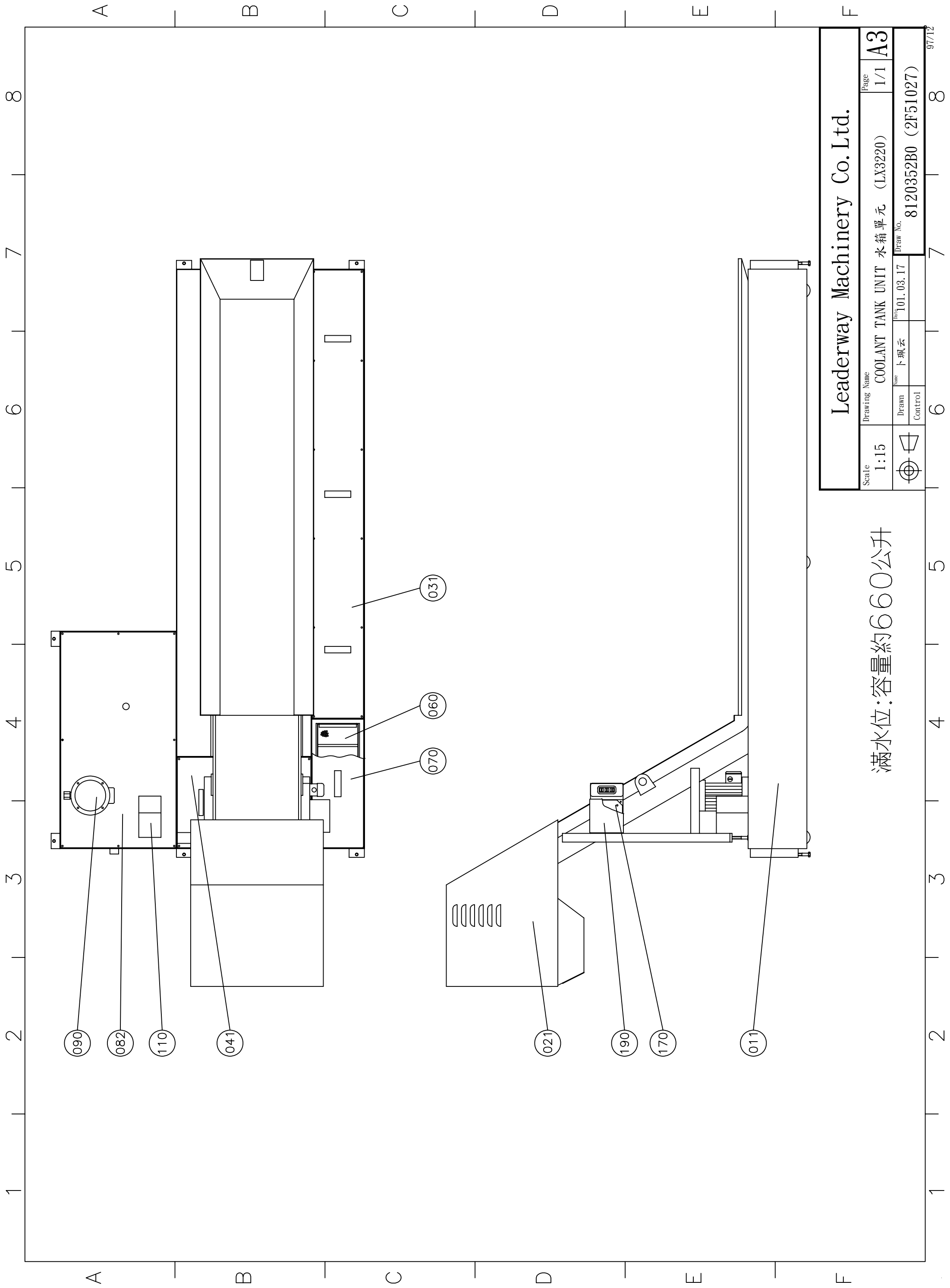

滿水位:容量約660公升

Leaderway Machinery Co. Ltd.

Scale	1:15	Drawing Name	COOLANT TANK UNIT 水箱單元 (LX3220)	Page	1/1
		Drawn	卜珉云	Draw No.	8120352B0 (2F51027)
		Control			

*單階材料用量清單

製表日期: 102-01-03

第1頁

主件品號	序號	元件品號	品名 英文品名	規 格	用 量
2F51027			水箱單元(龍船式) COOLANT UNIT (CHAIN TYPE CHIP (LX-3220 容量約為660公升	
	0011	3603394B0	水箱 COOLANT TANK	7580\SPCC	1
	0021	3603079A0	龍船式排屑機 CHIP CONVEYOR	9940\SPCC	1
	0031	3603395B0	水箱蓋板(一) COOLANT TANK COVER(1)	7510\SPCC	1
	0041	3603396B0	水箱蓋板(二) COOLANT TANK COVER(2)	7510\SPCC	1
	0060	3603398A0	蓄屑槽 FILTER NET	7590\網板	2
	0070	3603399A0	蓄屑槽蓋 FILTER NET COVER	7550\SPCC	2
	0082	3603406C0	泵浦固定板 PUMP BRACKET	7180\SPCC	1
	0090	4430040503	切削液泵浦(直立式) COOLANT PUMP	TPHK4T5-3	1
	0100	4510100001	油表 COOLANT LEVEL GAUGE	3''	1
	0110	4520900800	油水分離機 OIL WATER SEPARATOR	HD-800\皮帶長度為620長	1
	0120	3560442B0	蓄油桶 OIL REVIO	7580\SPCC	1
	0140	4180012720	直型高壓油管 HIGH-PRESSURE HOSE	1/2"R1x7200L	1
	0150	4180012570	直型高壓油管 HIGH-PRESSURE HOSE	1/2"R1x5700L	1
	0160	4180012520	直型高壓油管 HIGH-PRESSURE HOSE	1/2"R1x5200L	1
	0170	3540113B0	電氣盒蓋 TERMINAL BOX COVER	7210\SPCC	1
	0190	3603589A0	電氣盒(排屑機) TERMINAL BOX	7210\SPCC	1
	0200	3603793A0	蓄屑車(可倒式)	7520\市購品	1

<結 束>

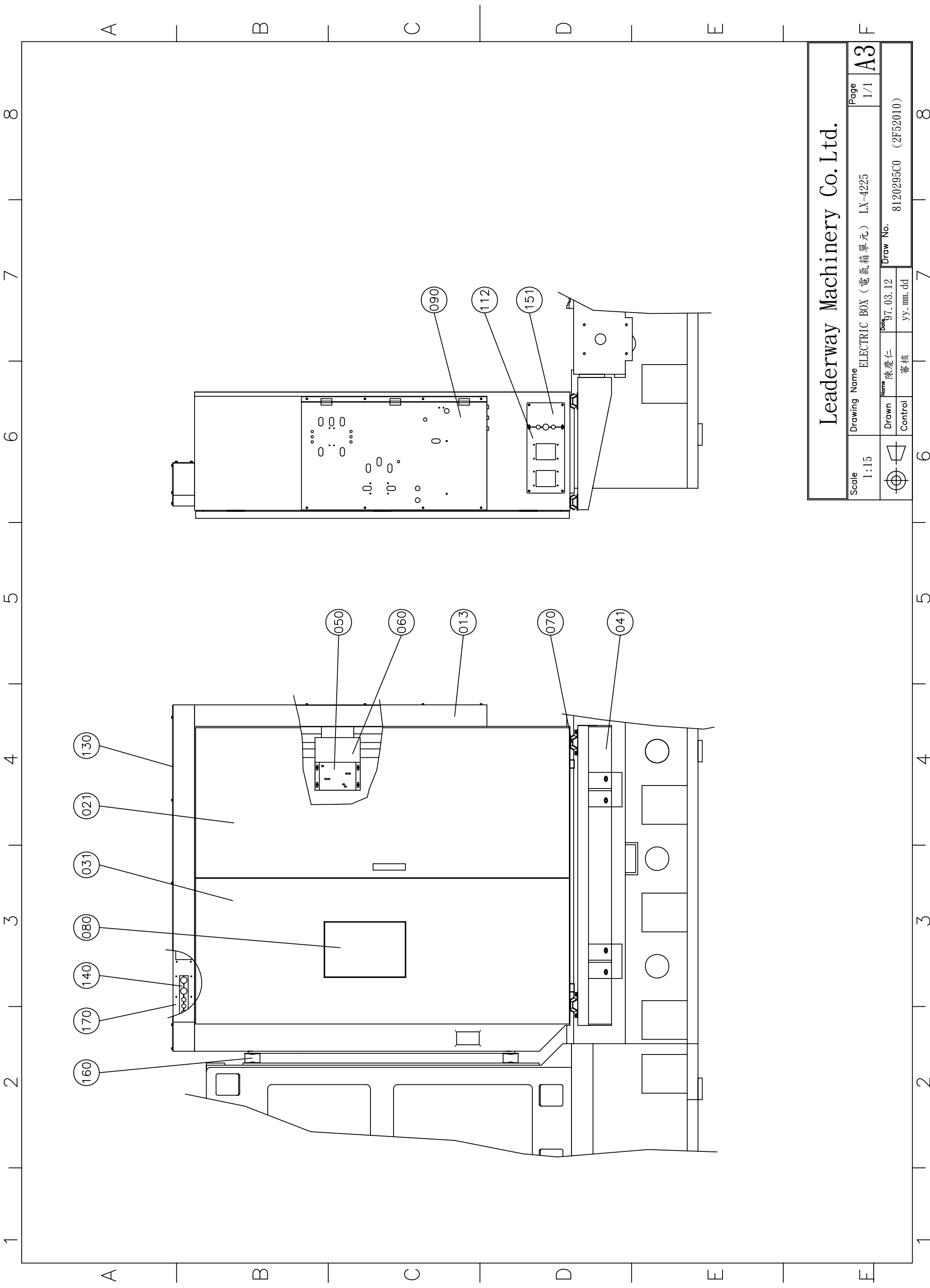

Leaderway Machinery Co. Ltd.

Scale 1:15	Drawing Name ELECTRIC BOX (電氣箱單元) LX-4225	Page 1/1
	Drawn 陳慶仁	Draw No. 8120295C0 (2F52010)
	Control 審核	
Date 97.03.12		8
yy. mm. dd		7

F A3

*單階材料用量清單

製表日期: 102-12-10

第1頁

主件品號	序號	元件品號	品名 英文品名	規 格	用 量
2F52010			電氣箱單元 POWER CABINET UNIT	LX-B\門柱(高)\F 18i	
	0014	3603062F0	電氣箱 POWER CABINET	7450\請改下3603062G0	1
	0021	3603064B0	電氣箱右門 (R) DOOR, POWER CABINET	7450\SPCC	1
	0032	3603063D0	電氣箱左門 (L) DOOR, POWER CABINET	7450\SPCC	1
	0041	3603065C0	電氣箱下固定座 LOWER BRACKET	7450\SPCC	1
	0050	3500150B0	左右調整座 ADJUSTABLE BRACKET	7160\請改下3500150C0	1
	0061	3600154C0	主電源開關座 MAIN POWER SWITCH BRACKET	7160\SPCC	1
	0070	4650200120	防震腳墊 CUSHION PAD	YS-120N	4
	0080	4560300025	熱交換器 HEAT EXCHANGER	HPW-25AR(箱內型)	1
	0090	3603232A0	電磁閥座固定板 VALVE BRACKET	7180\請改下3603232B0	1
	0114	3603191F0	出線板(一) CABLE CLAMP	7180\請改下3603191G0	1
	0130	3603213B0	配線槽蓋 ELECTRICAL CONDUIT COVER	7540\請改下3603213C0	1
	0140	3603215A0	線管夾板 CABLE CLAMP	7180\SPCC	2
	0151	3603216B0	線管夾板 CABLE CLAMP	7180\SPCC	1
	0160	4650112325	I型橡膠避震器 CUSHION PAD	YS-325I(M12) M12-M12-φ72-4	4
	0171	3603498B0	電氣箱上出線板(一) UPPER CABLE CLAMP(1)	7450\SPCC	1

<結 束>

1 2 3 4 5 6 7 8

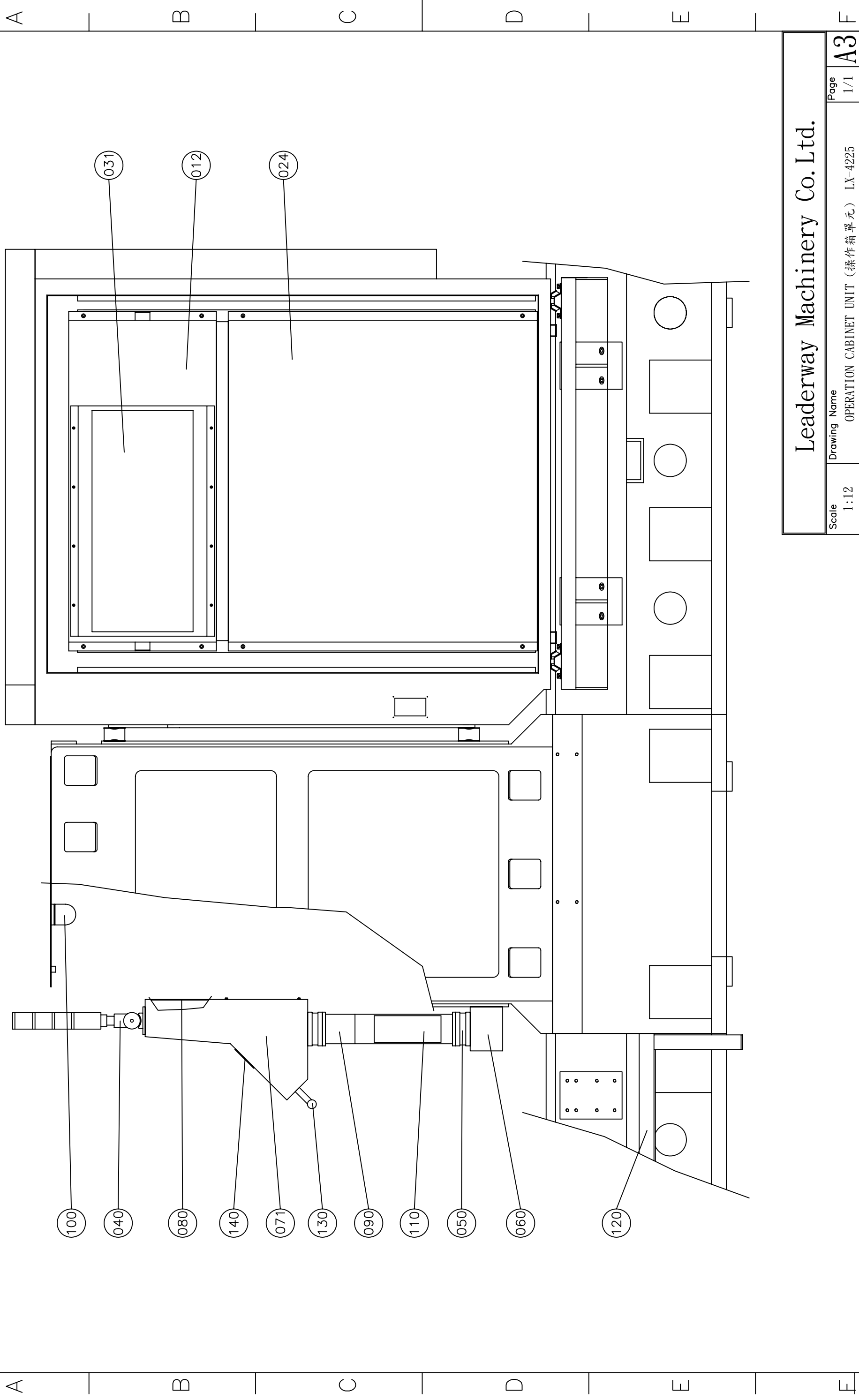

A | B | C | D | E | F

Leaderway Machinery Co. Ltd.			
Scale	Drawing Name	Page	
1:12	OPERATION CABINET UNIT (操作箱單元) LX-4225	1/1	A3
	Drawn	Draw No.	
	Control	97.03.12	8120296C0 (2F53022)
	Name	yy. mm. dd	
	陳慶仁	審核	

1 2 3 4 5 6 7 8

*單階材料用量清單

製表日期: 102-12-10

第1頁

主件品號	序號	元件品號	品名 英文品名	規 格	用量
2F53022			操作箱單元 F 18i OPERATION CABINET UNIT	LX-B\門柱(高)2284mm	
	0012	3603464B0	I/O基板 I/O BOARD	7560\請改下3603464C0	1
	0024	3603465C0	PC基板 PC BOARD	7560\SPCCZ	1
	0031	3560388C0	驅動器固定架(A) FIXED BRACKET(A), DRIVER	7560\SPCC	1
	0040	4720635243	警示燈(三層) WARNING LIGHT	SPE-35-24-3-B0-10 RYG	1
	0050	3500129A0	旋轉座 ROTATION BRACKET	3240\S45C	2
	0060	3603073B0	操作箱連結座 OPERATION CABINET BRACKET	7460\SPCC	1
	0071	3603204C0	操作箱 OPERATION CABINET	7460\SPCC	1
	0080	3603205A0	操作箱後蓋 CABINET REAR COVER	7460\SPCC	1
	0090	3603206A0	伸臂(操作箱) OUTSTRETCHED ARM	7470\SPCC	1
	0100	4720724140	工作燈 WORKING LIGHT	JF-WN40D\接頭3/8"	1
	0110	3603207A0	伸臂蓋板 OUTSTRETCHED ARM COVER	7180\SPCC	1
	0120	3603208B0	腳踏板架 STEP PADEL BRACKET	7210\角鐵	1
	0130	4300400400	管型把手(自然色) HAHDLE	U1-400L	1
	0140	3520082A0	銘牌 NAME PLATE	4350\鋁板	1

<結 束>