



Leaderway VERTICAL MACHINING CENTER
(BOX WAY)

VERTICAL MACHINING CENTER

PARTS LIST

MV1100S、MV1100D、MV1300S、MV1300D

LEADERWAY CNC TECHNOLOGIES CO., LTD.
NO. 36, Ln. 211, Taiming Rd.,
Wuri Dist, TAICHUNG 41468, TAIWAN
TEL: +886-4-2335-0711
FAX: +886-4-2335-0986



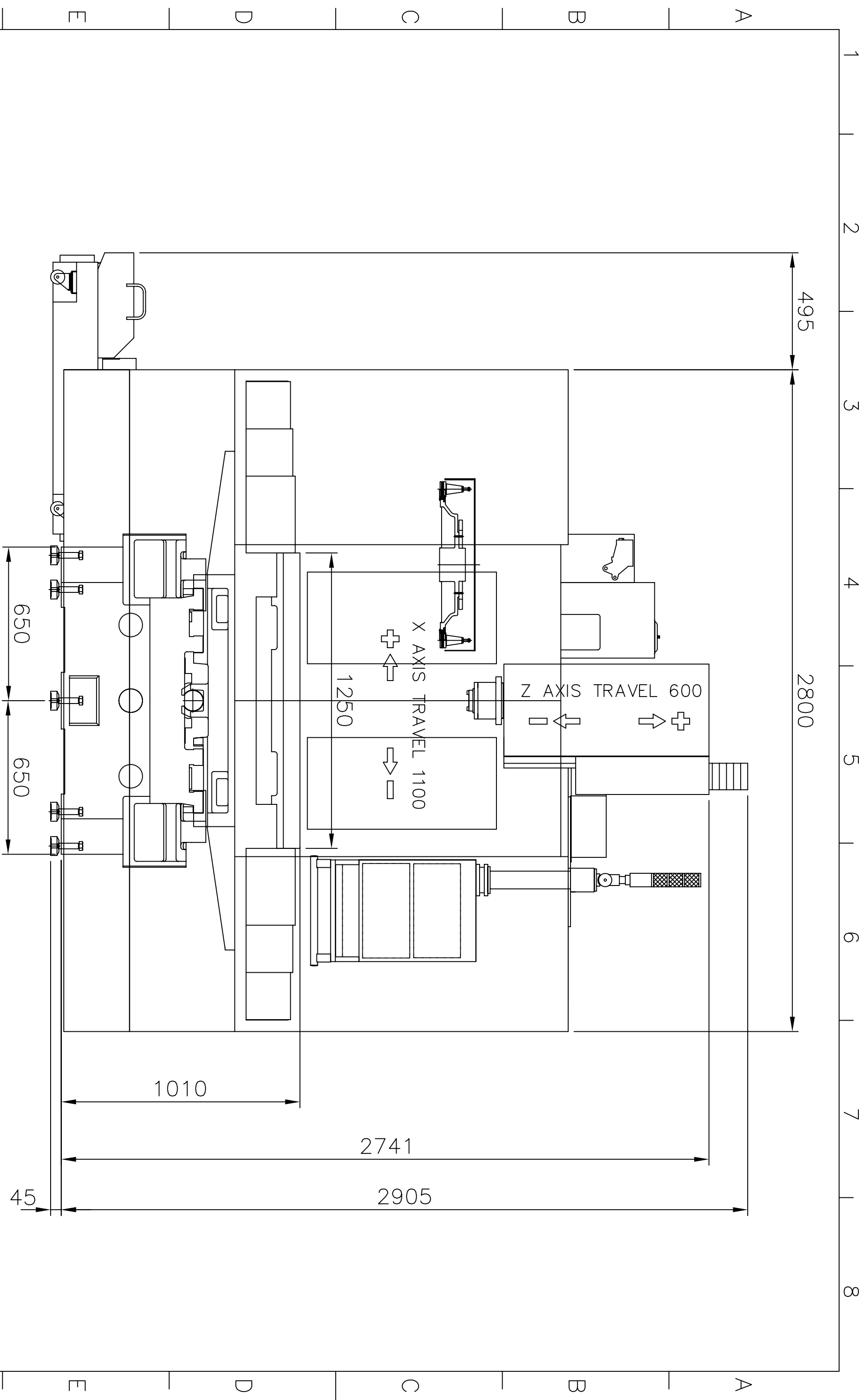

Leaderway Machinery Co. Ltd.

Scale		Drawing Name		Page	
1:15		OUTLINE DIMENSION (FRONT VIEW) 外型尺寸圖		1/3	
Drawn		Name		Draw No.	
AMY		AMY		8150054C0 (MW1100S)	
Control		卜塚云			
		Post			
		97.05.20			
		98.09.29			

A3

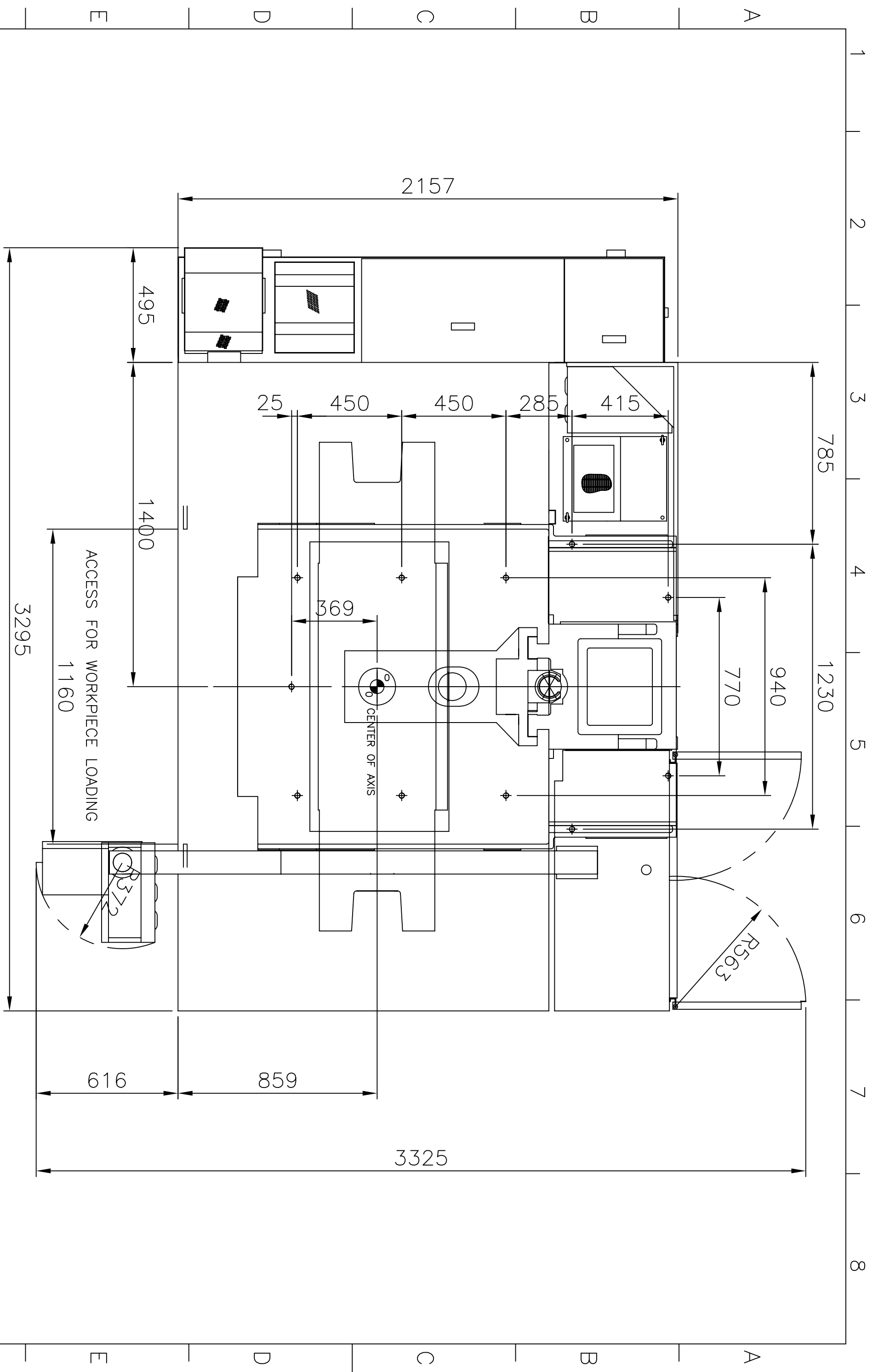

Leaderway Machinery Co. Ltd.

Scale		Drawing Name		Page	
1:15		OUTLINE DIMENSION (TOP VIEW) 外型尺寸圖		2/3	
Drawn	Name	Date	Draw No.	A3	
Control	AMY	97.05.20	8150054C0 (MW1100S)		
	卜塚云	98.09.29			

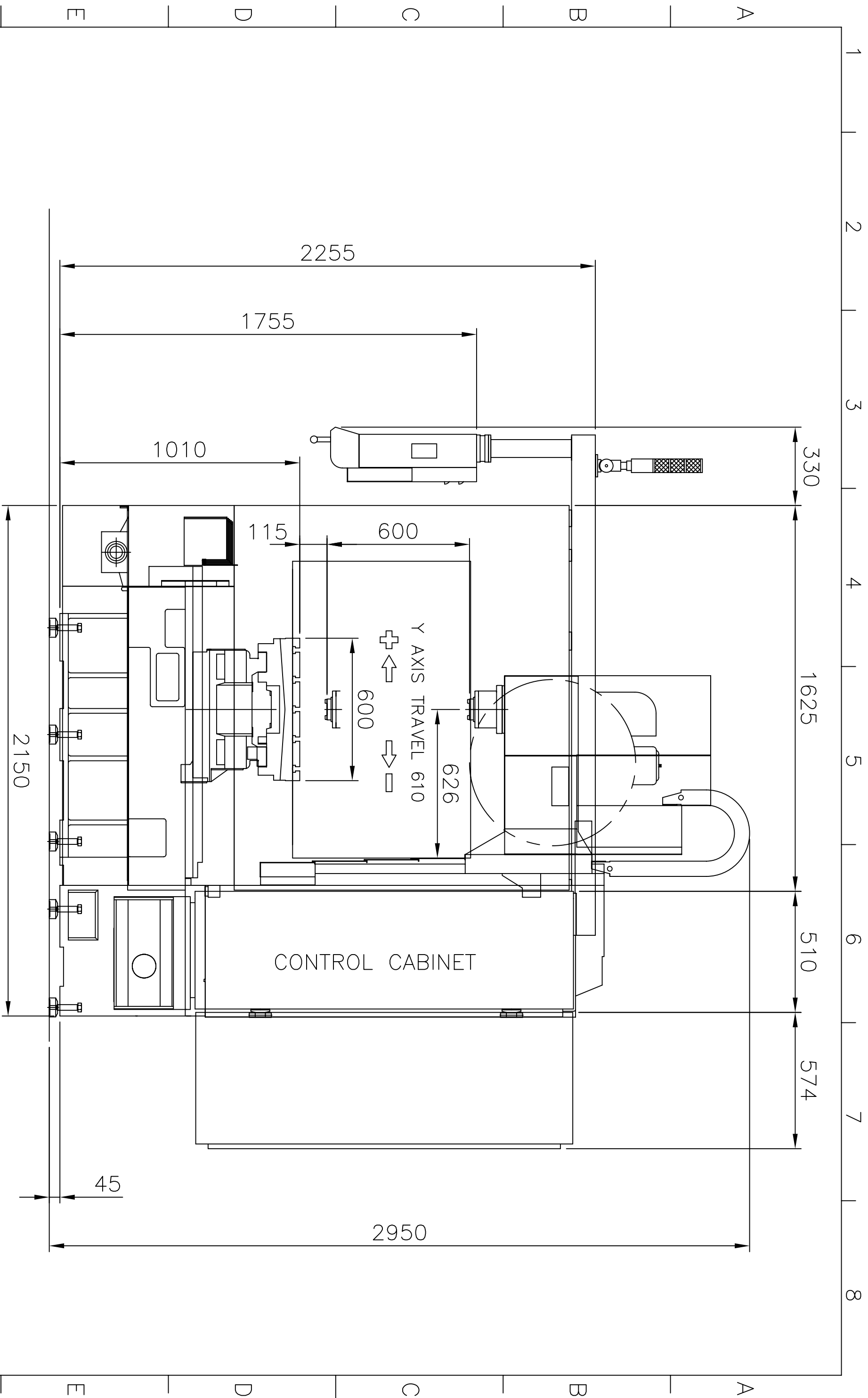

Leaderway Machinery Co. Ltd.

Scale	Drawing Name			Page
1:15	OUTLINE DIMENSION (RIGHT SIDE VIEW) 外型尺寸圖			3/3
Drawn	Name	Date	Draw No.	A3
Control	AMY	97.05.20	8150054C0 (MW1100S)	

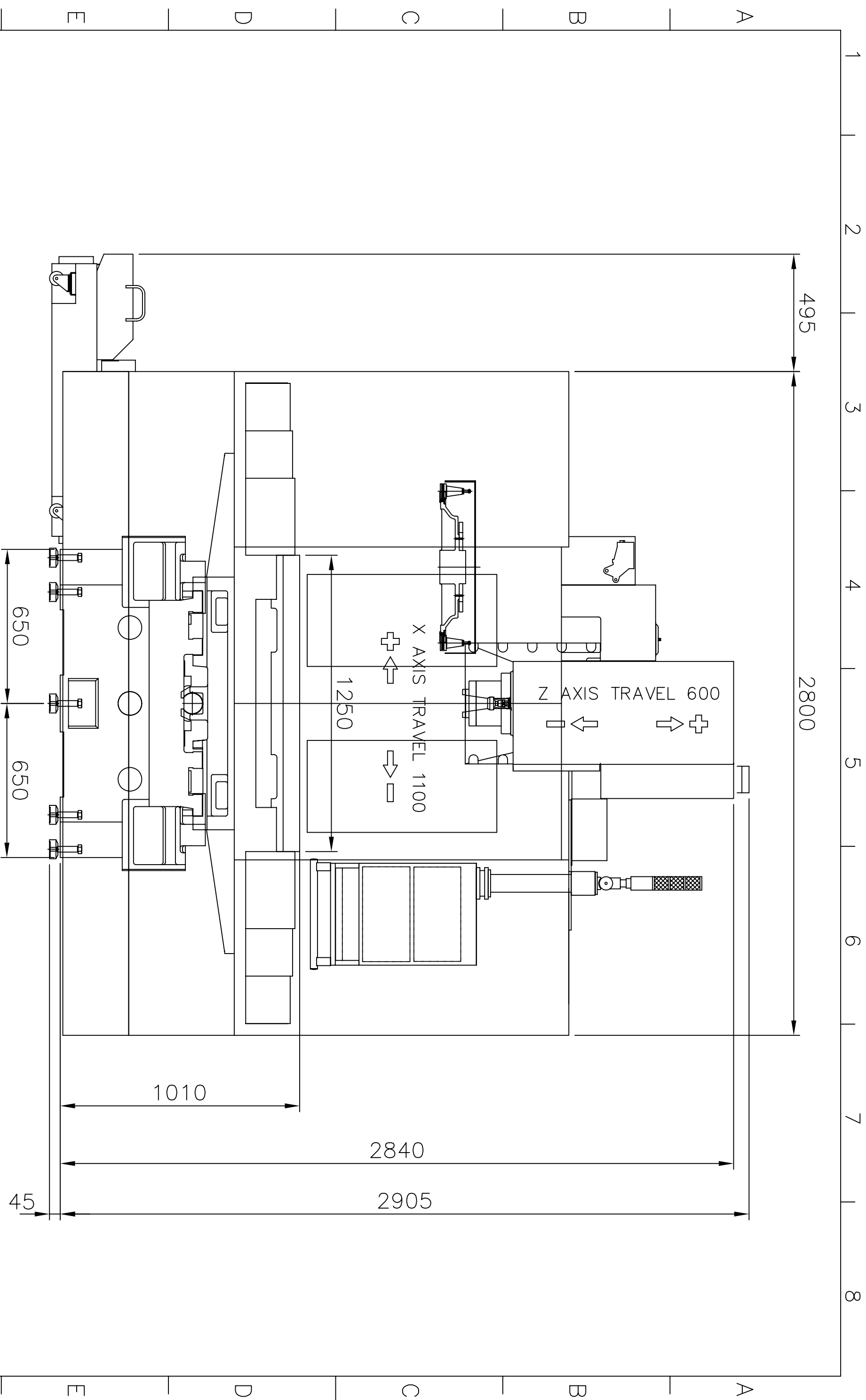

Leaderway Machinery Co. Ltd.

Scale 1:15	Drawing Name OUTLINE DIMENSION (FRONT VIEW) 外型尺寸圖			Page 1/3
Drawn AMY	Name 卜塚云	Date 97.05.21	Draw No. 8150079B0 (MV1100D)	A3
Control		98.09.29		

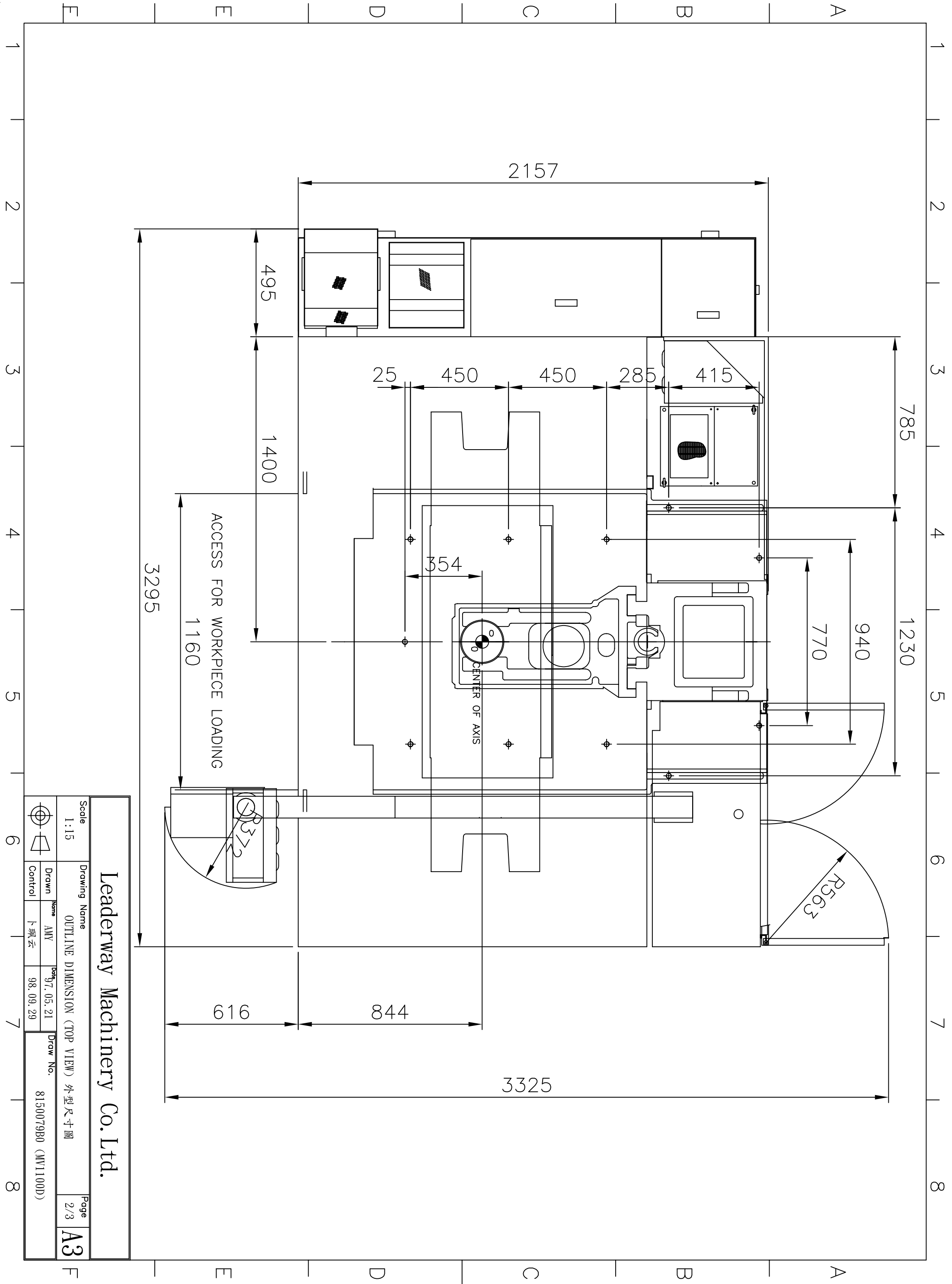

Leaderway Machinery Co. Ltd.

Scale	Drawing Name			Page
1:15	OUTLINE DIMENSION (TOP VIEW) 外型尺寸圖			2/3
Drawn	Name	Date	Draw No.	A3
Control	AMV	97.05.21	8150079B0 (M1100D)	
		卜須云	98.09.29	

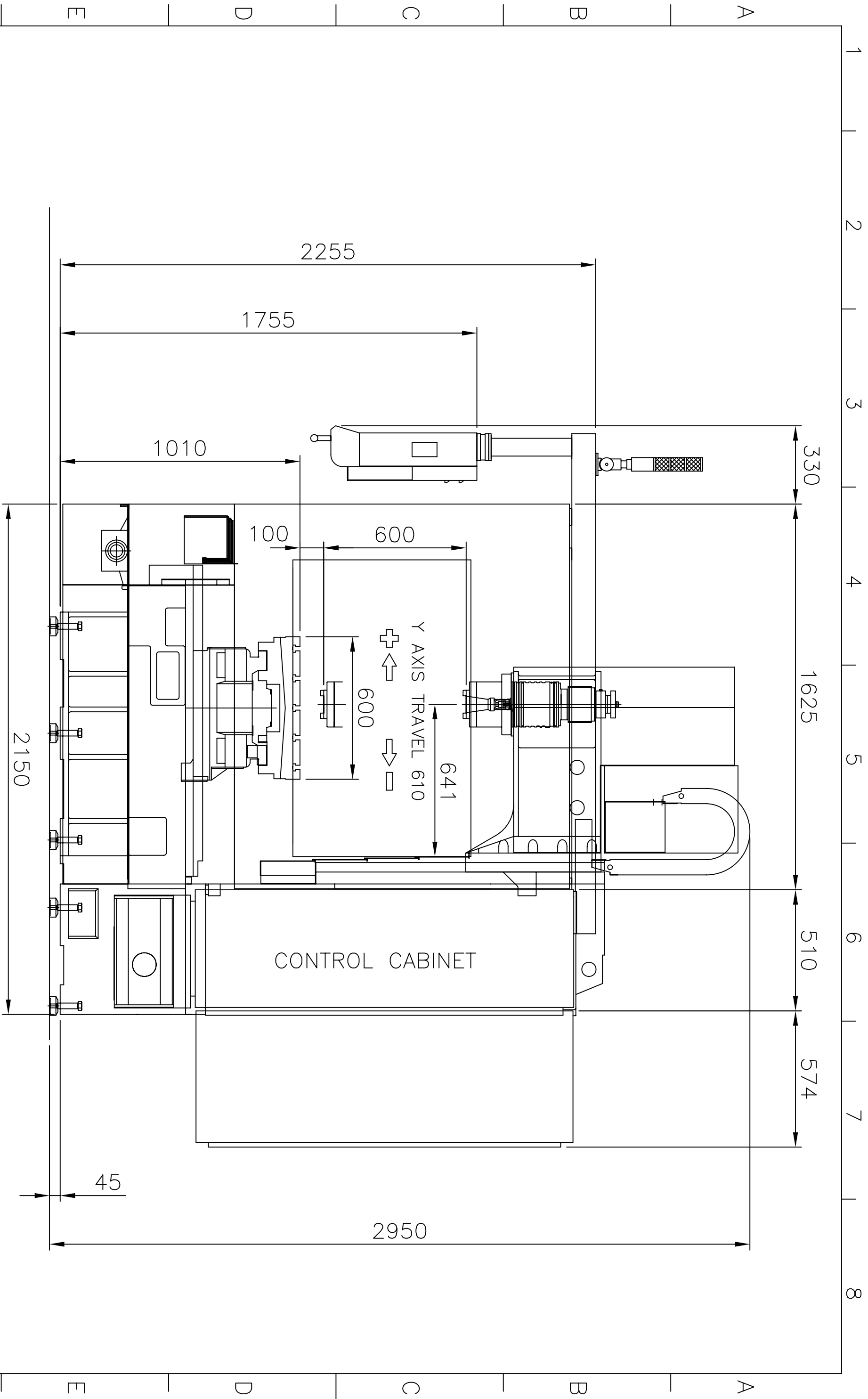

Leaderway Machinery Co. Ltd.

Scale		Drawing Name		Page	
1:1.5		OUTLINE DIMENSION (RIGHT SIDE VIEW) 外型尺寸圖		3/3	
Drawn		Name		Date	
Control		AMY		97.05.21	
		卜佩云		98.09.29	
		Draw No.		8150079B0 (MW1100D)	

A3

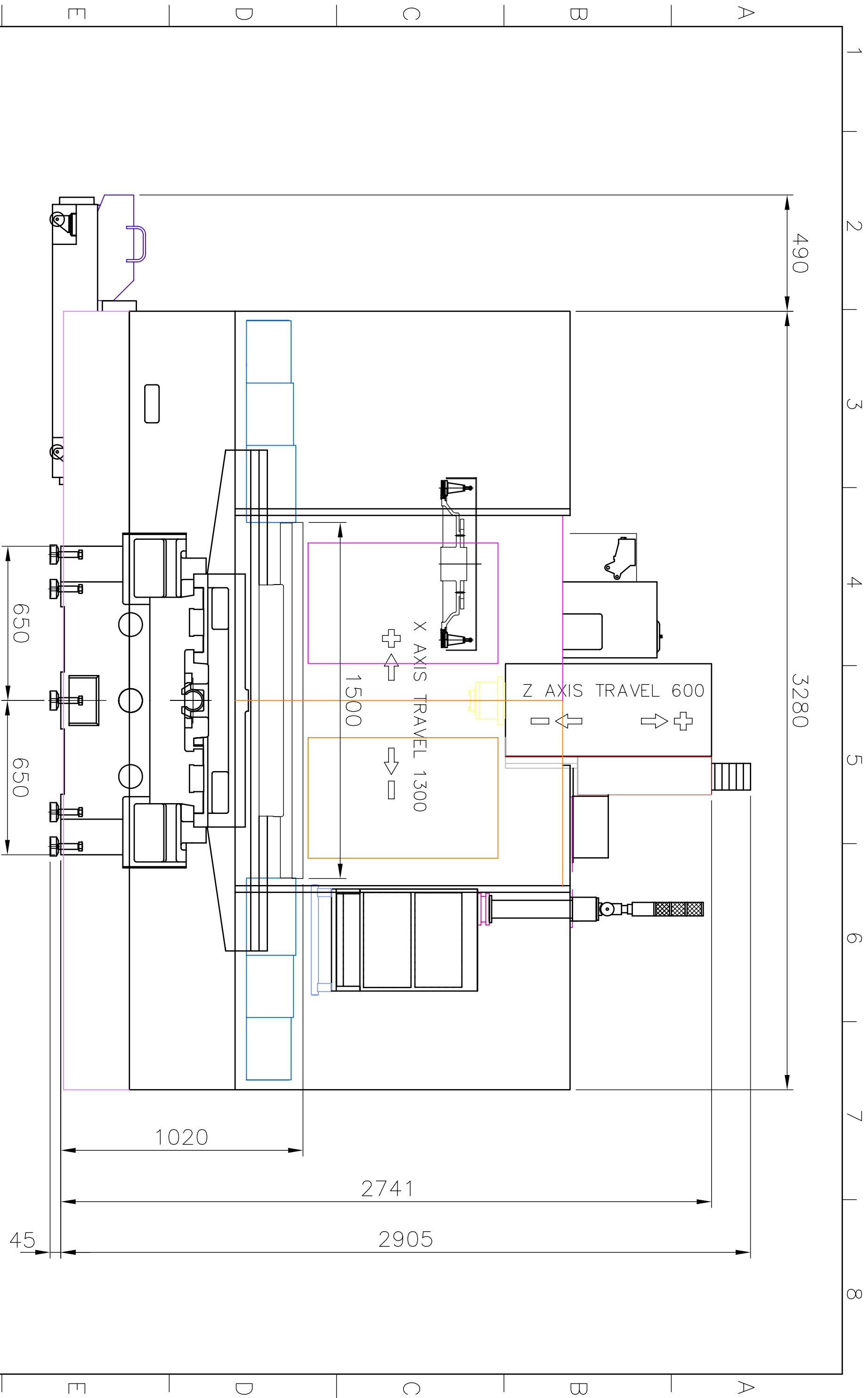

Leaderway Machinery Co. Ltd.

Scale	Drawing Name			Page
1:15	OUTLINE DIMENSION (FRONT VIEW) 外型尺寸圖			1/3
Drawn	Name	Date	Draw No.	A3
Control	AMY	97.05.22	8150092B0 (MW1300S)	

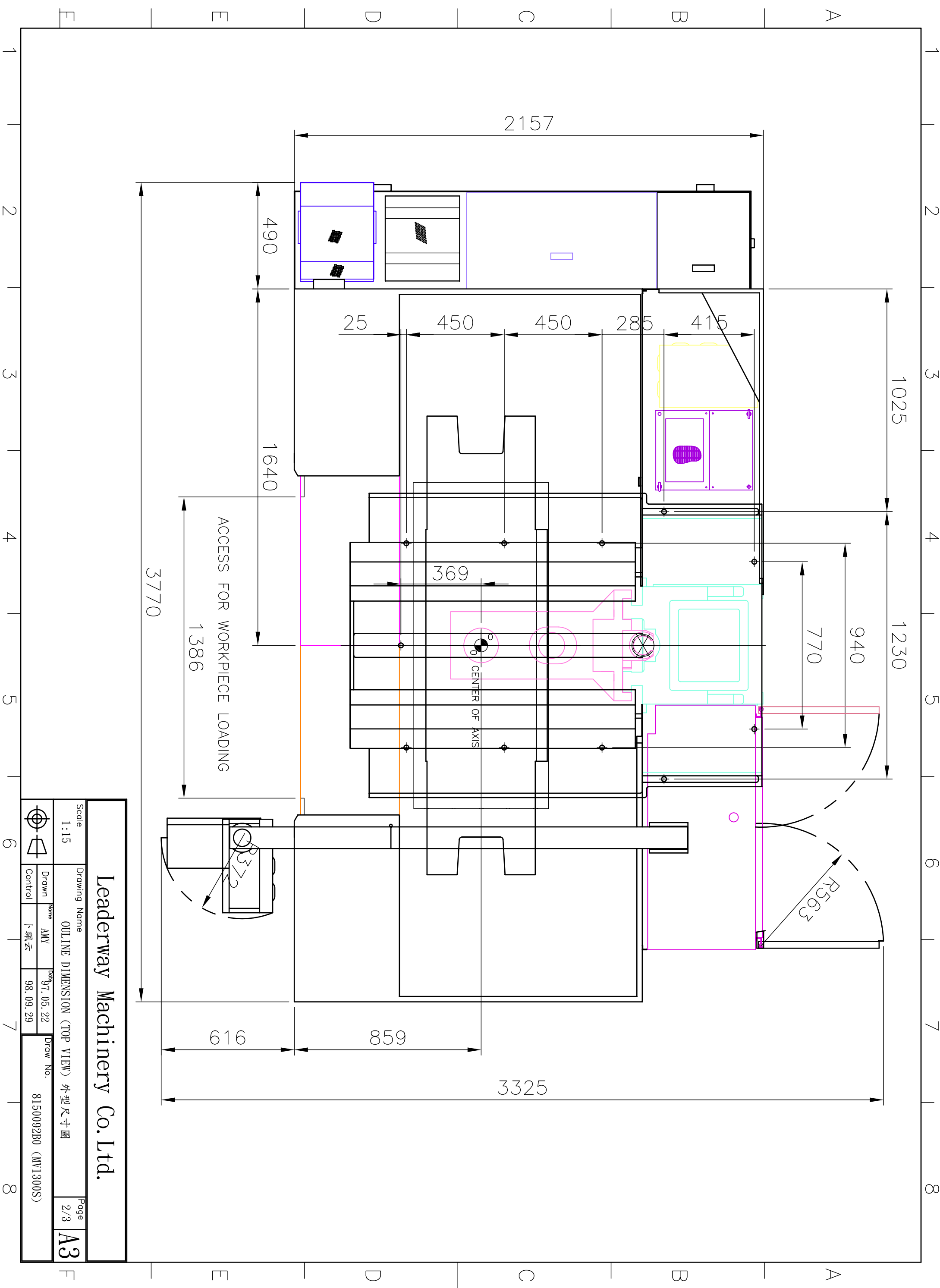

Leaderway Machinery Co. Ltd.

Scale		Drawing Name		Page	
1:15		OULINE DIMENSION (TOP VIEW) 外型尺寸圖		2/3	
Drawn	Name	Date	Drwg. No.	A3	
Control	AMY	97.05.22	8150092B0 (MW1300S)		
	卜珉云	98.09.29			

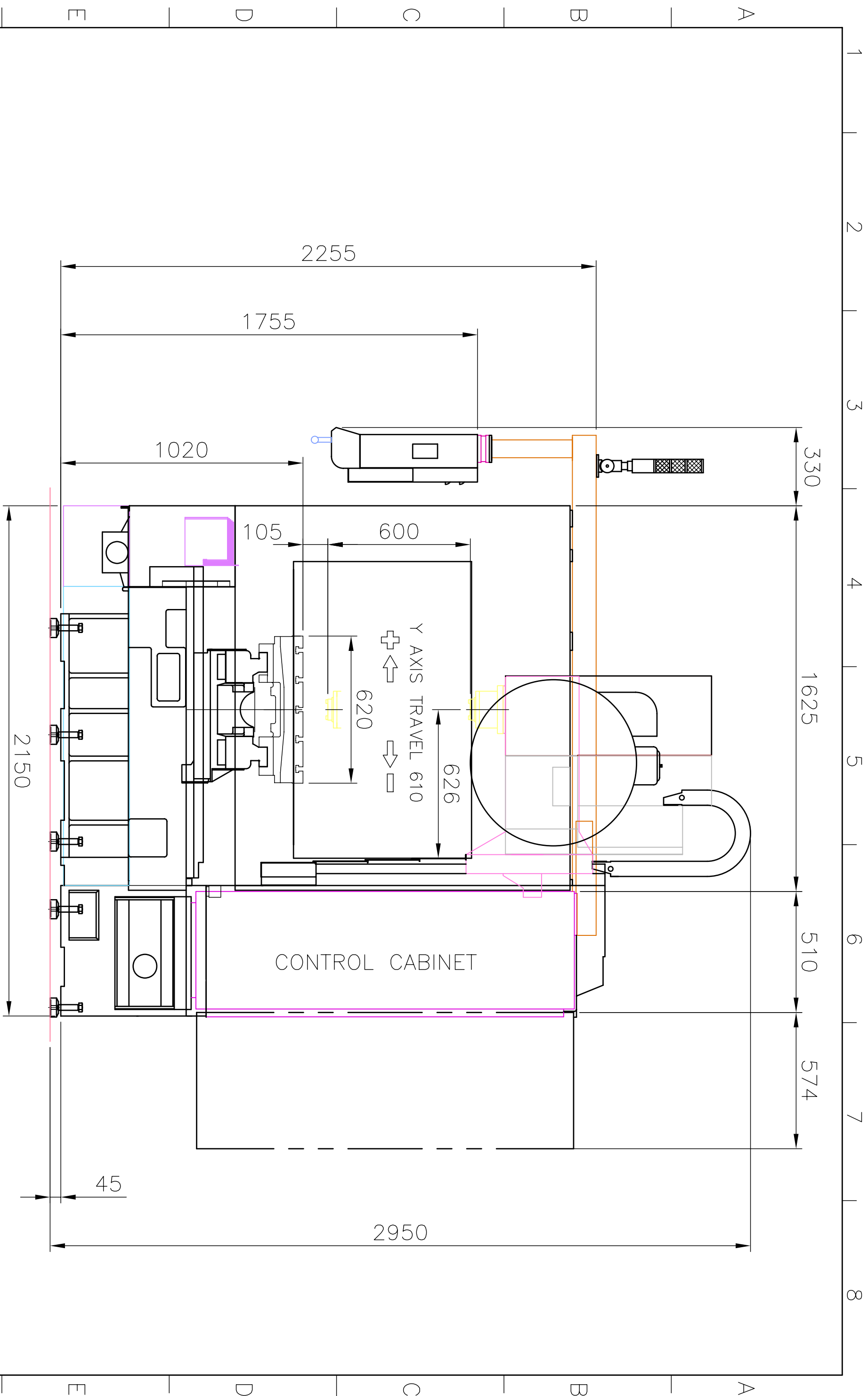

Leaderway Machinery Co. Ltd.

Scale	Drawing Name			Page
1:15	OUTLINE DIMENSION (RIGHT SIDE VIEW) 外型尺寸圖			3/3
Drawn	Name	Date	Draw No.	A3
Control	AMY	97.05.22	8150092B0 (MW1300S)	
		98.09.29		

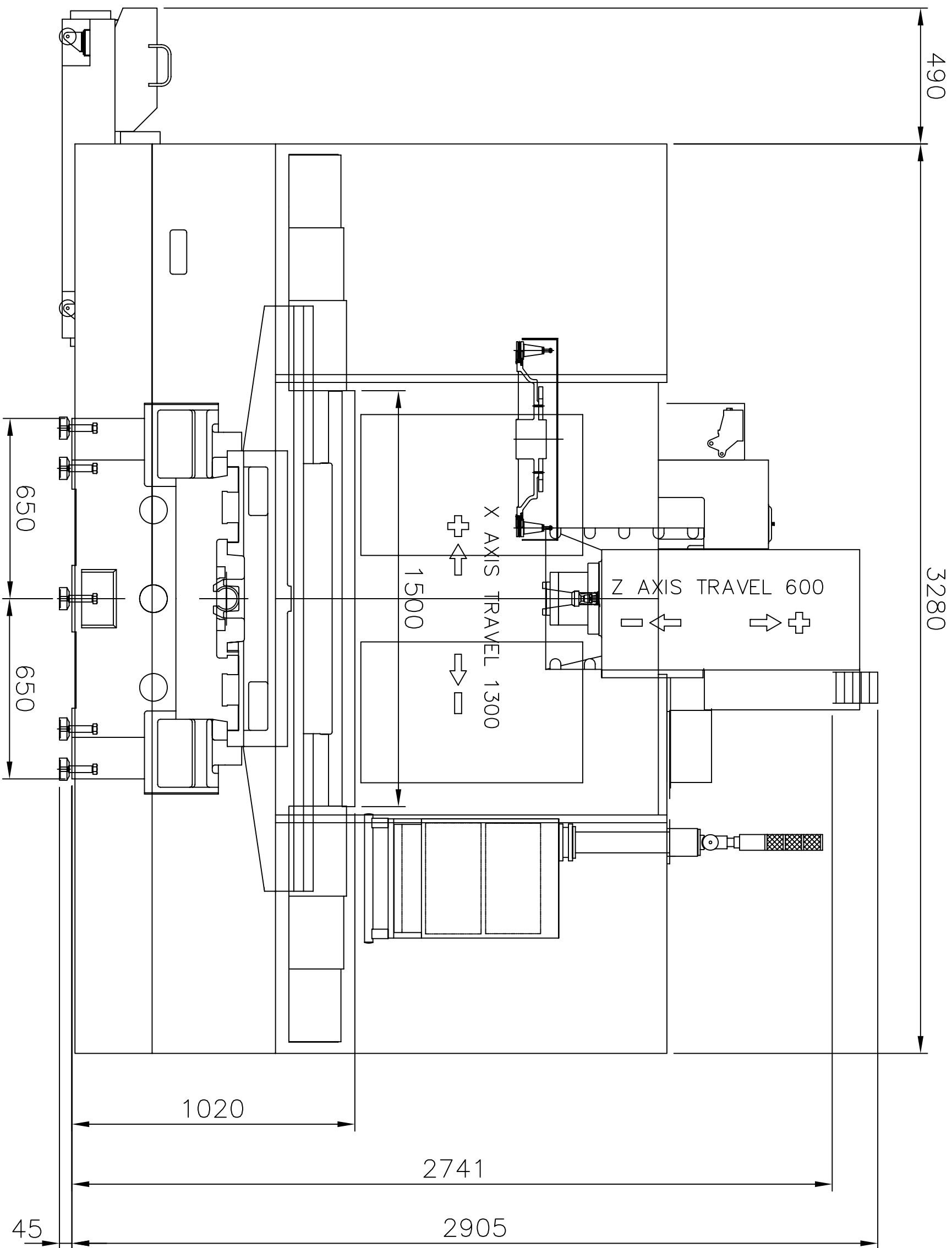

Leaderway Machinery Co. Ltd.

Scale	Drawing Name			Page
1:15	OUTLINE DIMENSION (FRONT VIEW) 外型尺寸圖			1/3
Drawn	Name	Date	Draw No.	A3
Control	AMY	97.05.22	8150120B0 (MW1300D)	

1 2 3 4 5 6 7 8

A B C D E F

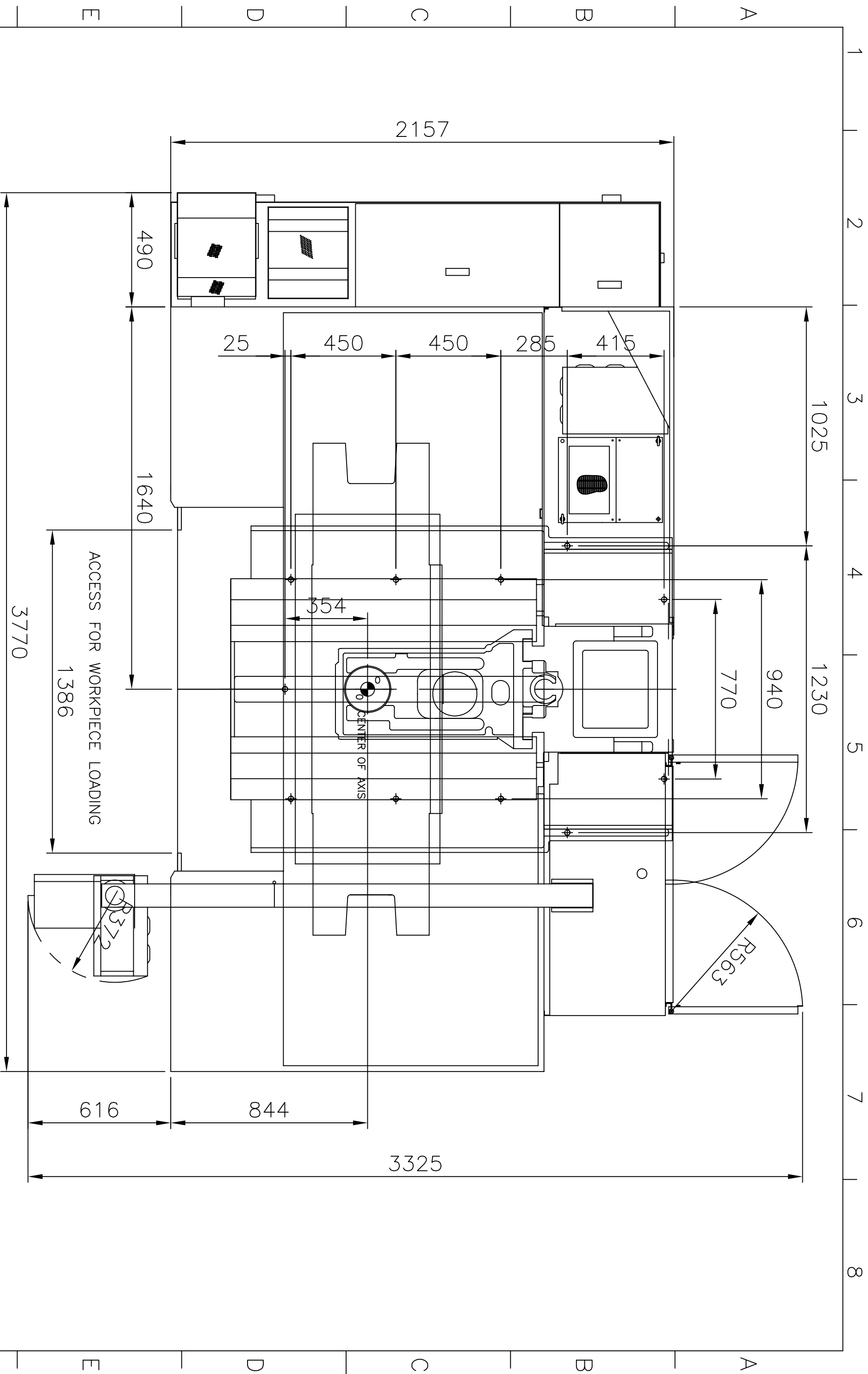

Leaderway Machinery Co. Ltd.

Scale	Drawing Name			Page
1:15	OUTLINE DIMENSION (TOP VIEW) 外型尺寸圖			2/3
Drawn	Name	Date	Draw No.	A3
AMY	AMY	97.05.22	8150120B0 (MT1300D)	
Control	卜楓云			

1 2 3 4 5 6 7 8

A B C D E F

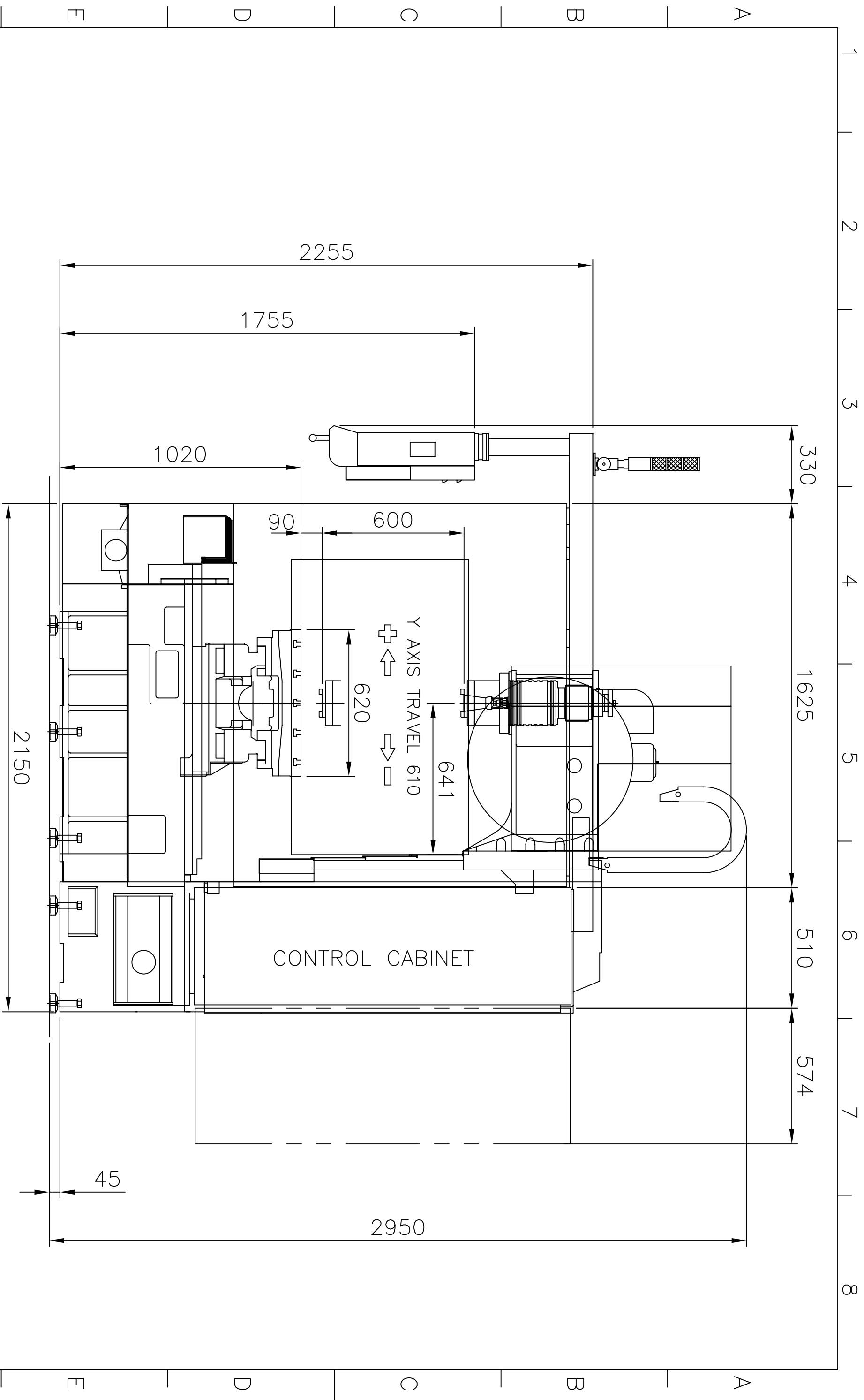

Leaderway Machinery Co. Ltd.

Scale	Drawing Name			Page
1:15	OUTLINE DIMENSION (RIGHT SIDE VIEW) 外型尺寸圖			3/3
Drawn	Name	Date	Draw No.	A3
Control	AMY	97.05.22	8150120B0 (MV1300D)	
		98.09.29		

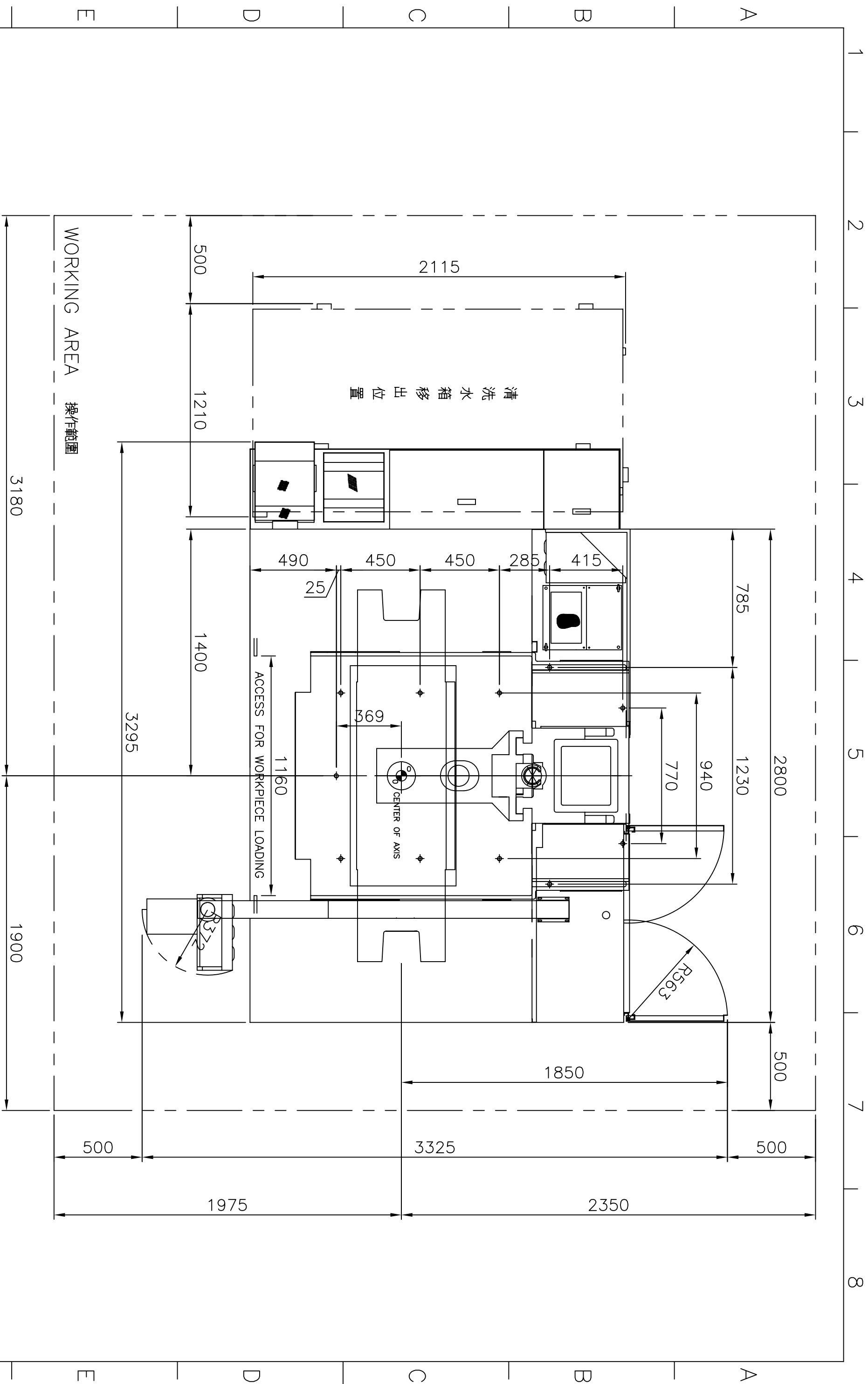

Leaderway Machinery Co. Ltd.

Scale		Drawing Name		Page	
1:20		FOUNDATION ANCHOR SET UP DRAWING (地基圖)		1/2	
Drawn	Name	Date	Draw No.	A3	
Control	卜珮云	98.09.29	8150054C0 (MV1100S+標準水箱)		

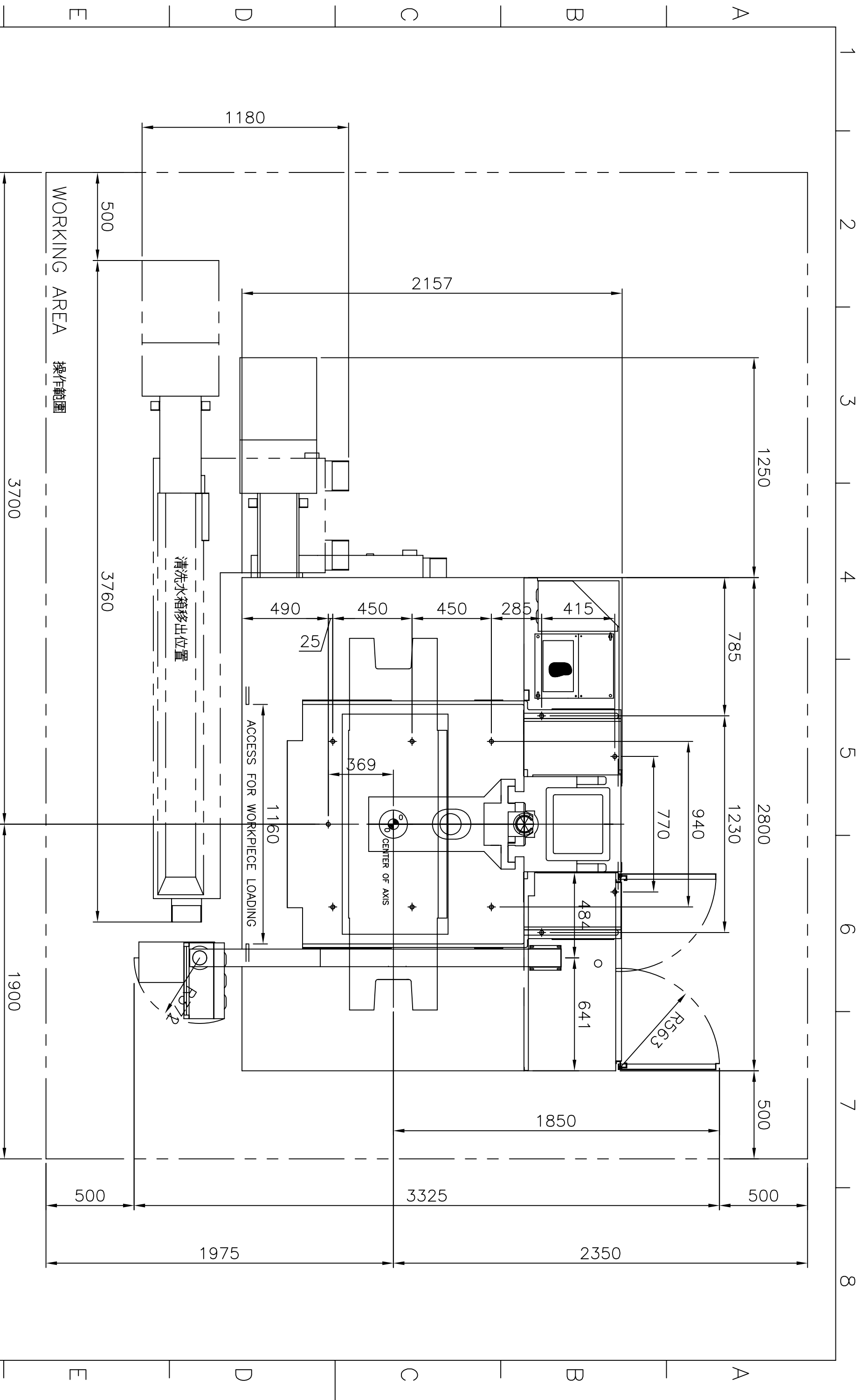

CHIP CONVEYOR (OPTION)

Leaderway Machinery Co. Ltd.

Scale	Drawing Name			Page
1:20	FOUNDATION ANCHOR SET UP DRAWING (地基圖)			2/2
Drawn	Name	Date	Draw No.	A3
Control	卜珮云	97.09.05	8150054C0 (W1100S+龍船式排屑機)	

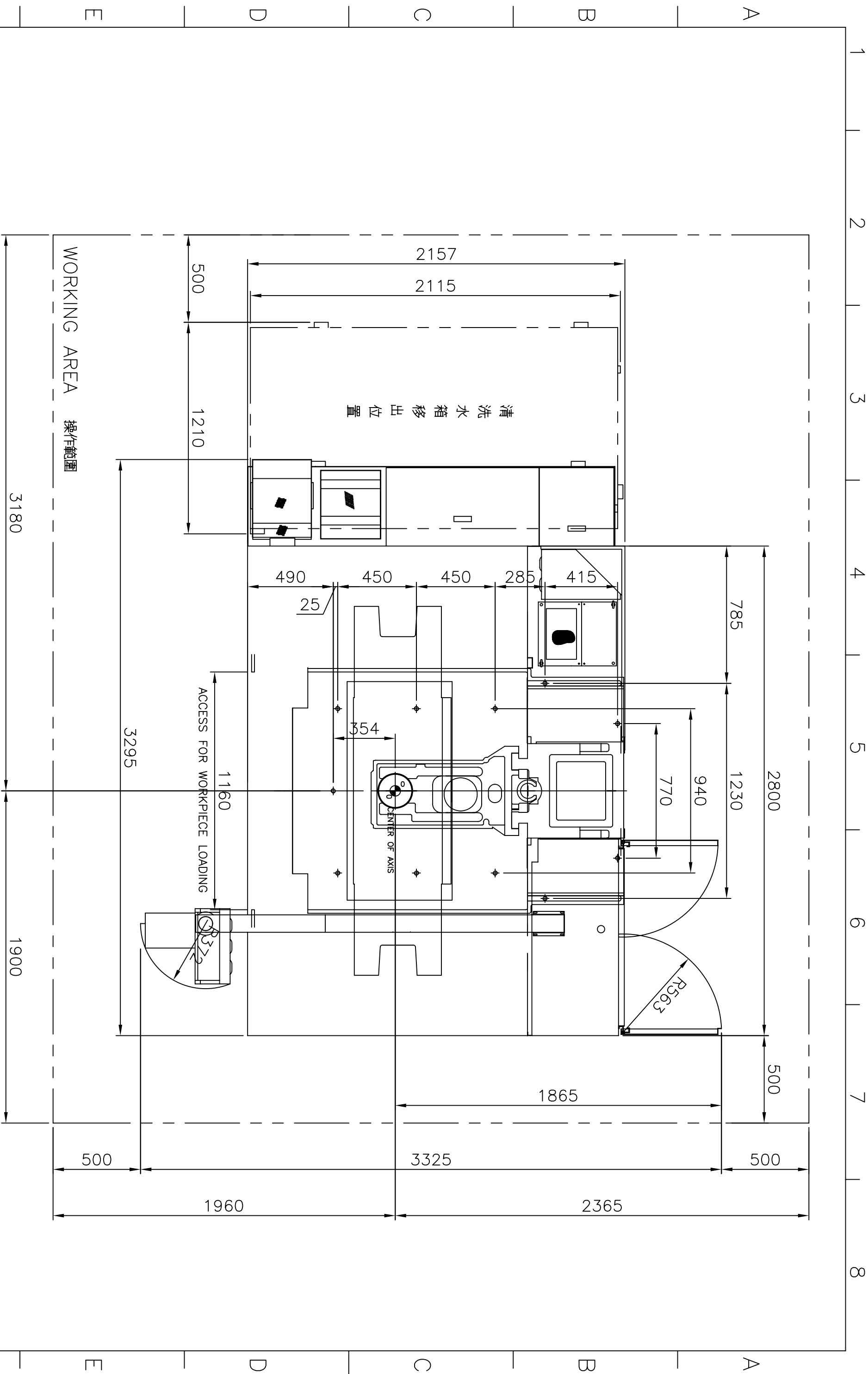

Leaderway Machinery Co. Ltd.

Scale	Drawing Name			Page
1:20	FOUNDATION ANCHOR SET UP DRAWING (地基圖)			1/2
Drawn	Name	Date	Draw No.	A3
Control	卜珮云	97.09.08	8150079B0 (WV1100D+標準水箱)	

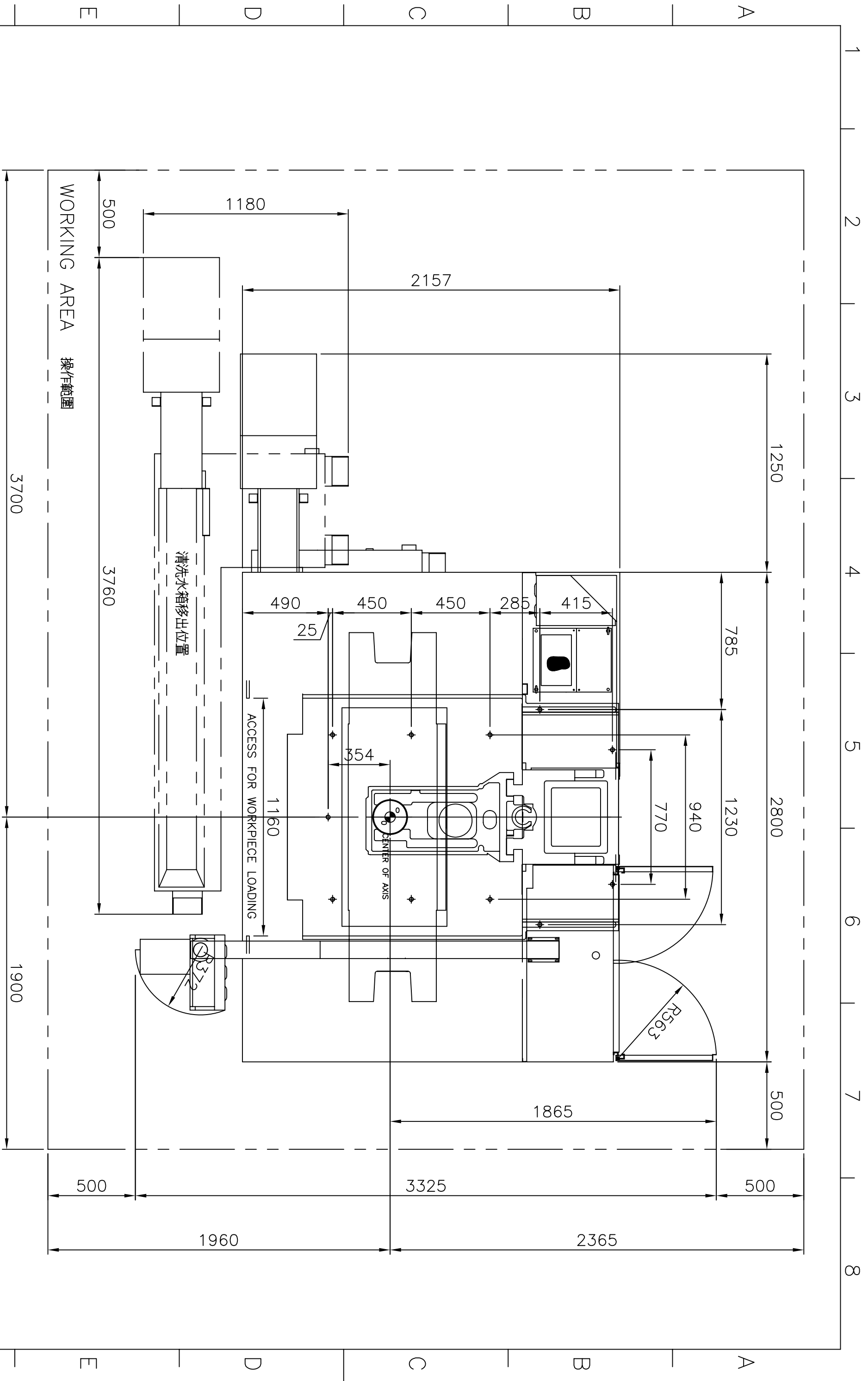

CHIP CONVEYOR (OPTION)

Leaderway Machinery Co. Ltd.

Scale		Drawing Name		Page	
1:20		FOUNDATION ANCHOR SET UP DRAWING (地基圖)		2/2	
Drawn		Date		Draw No.	
卜珮云		97.09.08		8150079B0 (M1100D+龍船式排屑機)	
Control		卜珮云			

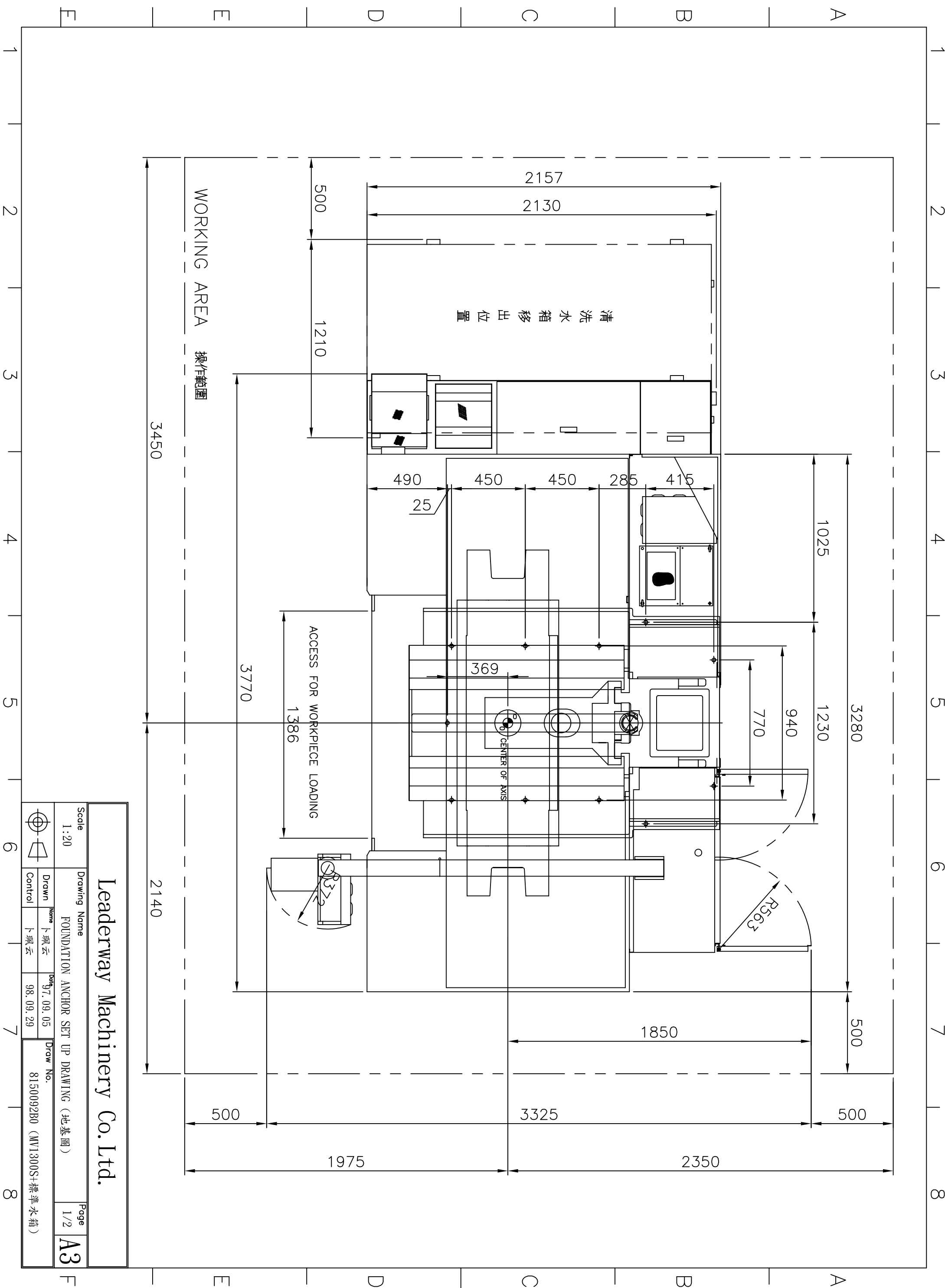

Leaderway Machinery Co. Ltd.

Scale		Drawing Name		Page	
1:20		FOUNDATION ANCHOR SET UP DRAWING (地基圖)		1/2	
Drawn		Name		Date	
卜秉云		卜秉云		97.09.05	
Control		卜秉云		98.09.29	
Draw No.		8150092B0 (MW1300S+標準水箱)			

A3

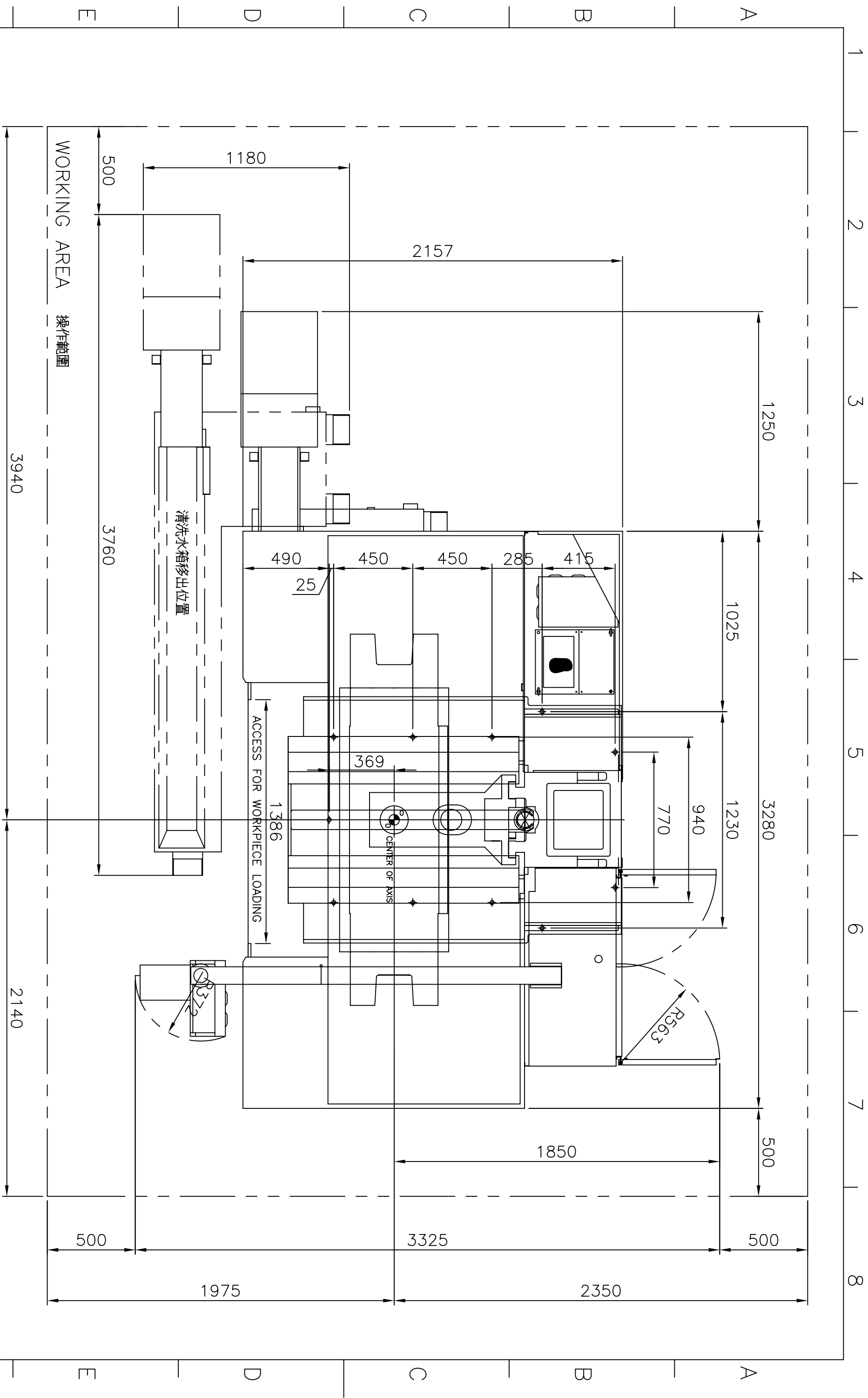

CHIP CONVEYOR (OPTION)

Leaderway Machinery Co. Ltd.

Scale	Drawing Name			Page
1:20	FOUNDATION ANCHOR SET UP DRAWING (地基圖)			2/2
Drawn	Name	Date	Draw No.	A3
Control	卜瑛云	97.09.08	8150092B0 (MW1300S+龍船式排屑機)	

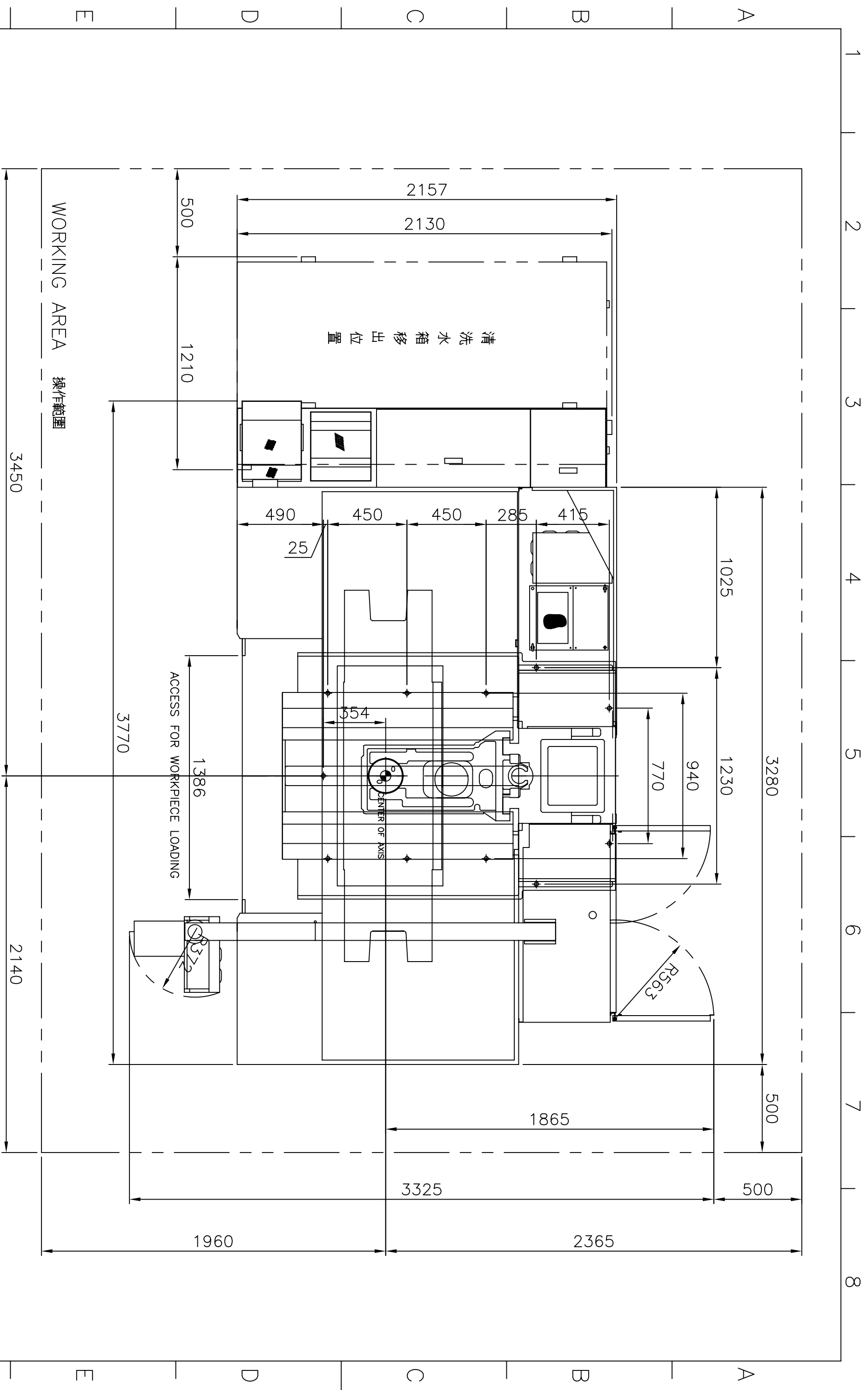

Leaderway Machinery Co. Ltd.

Scale		Drawing Name		Page	
1:20		FOUNDATION ANCHOR SET UP DRAWING (地基圖)		1/2	
Drawn		Date		Draw No.	
卜珉云		97.09.08		8150120B0 (MW1300D+標準水箱)	
Control		Date			
卜珉云		98.09.29			

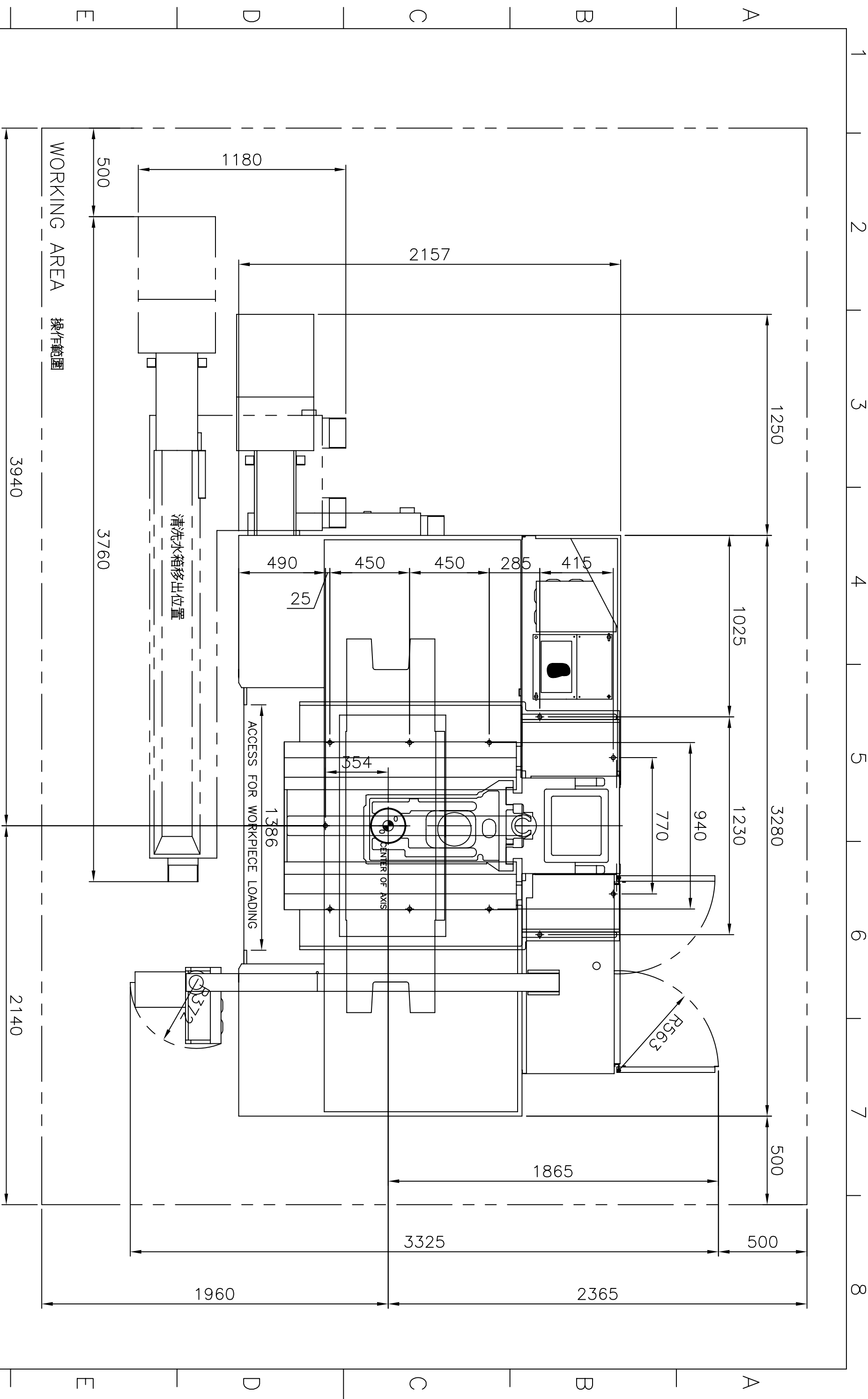

CHIP CONVEYOR (OPTION)

Leaderway Machinery Co. Ltd.

Scale	1:20			Page	2/2
Drawing Name	FOUNDATION ANCHOR SET UP DRAWING (地基圖)			Draw No.	A3
Drawn	卜根云	Date	97.09.08		
Control	卜根云	Date	98.09.29	8150120B0 (MV1300D+龍船式排屑機)	

A=350(V450/V650(V650HSM)/V331/V421)
 A=500(V1100/MV1100S/MV1100D/MV1300D/LX8/LX10)
 A=700(LX1600/LX2200)
 A=1000(LX-B,....)

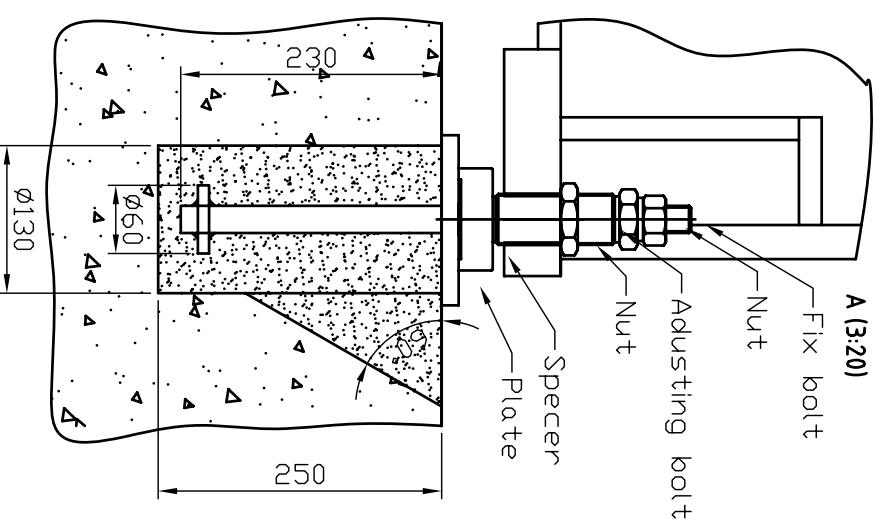
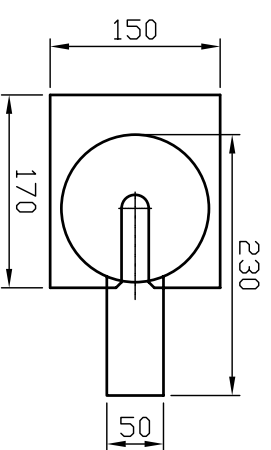
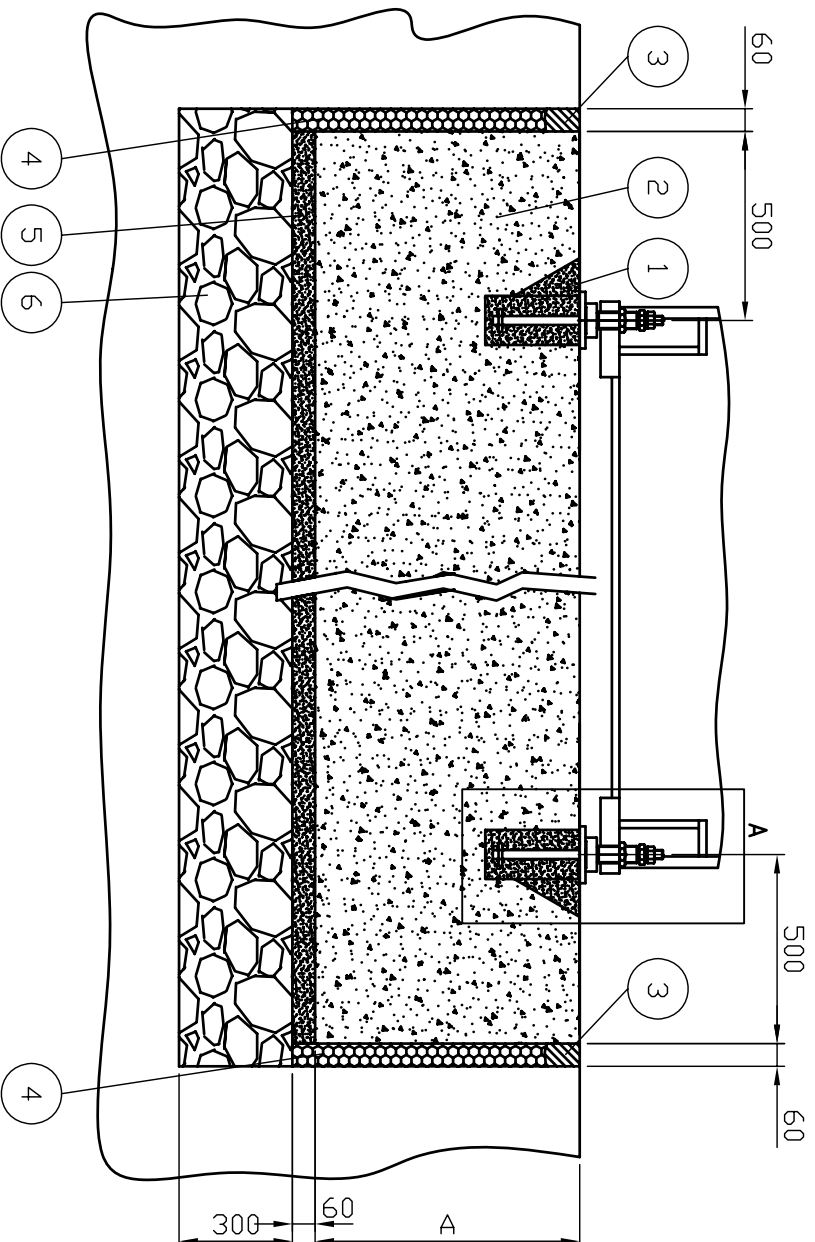

- 1> Concrete 5000pci
- 2> concrete 3000pci
- 3> Anti-oil/heat branze
- 4> Anti-vibration polyfoam
- 5> Anti-vibration sand
- 6> Round-shaps ston Dia. 150~300

Leaderway Machinery Co. Ltd.

Scale
1:20

Drawing Name

PROCESS OF SETTING (地基施工圖)

Page

1/2
A4

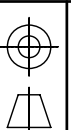

Drawn
Control

jack
jack

Date
96. 11. 20
96. 11. 20

Date
96. 11. 20

Draw No.

8150198B0 (全機型)

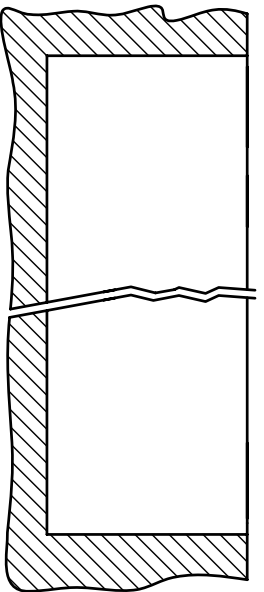

According to foundation drawing set the foundation area

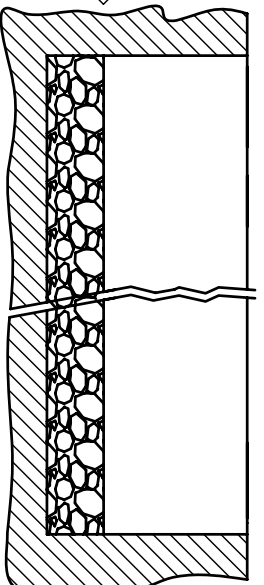

Firste, put stones on the bottom
stone dia 10mm~300mm

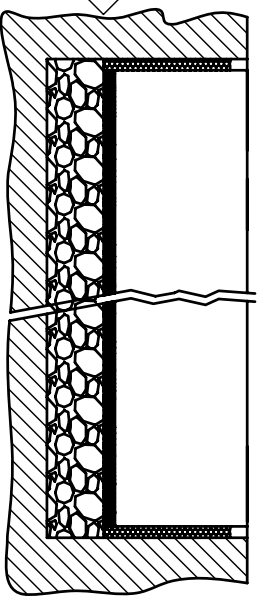

Fill up the sand and styrofoam plate on the other side

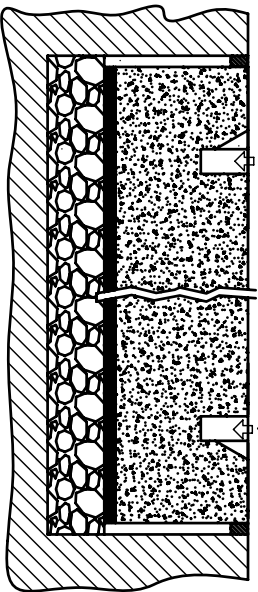

hoist machine higher and install the anchor bolts

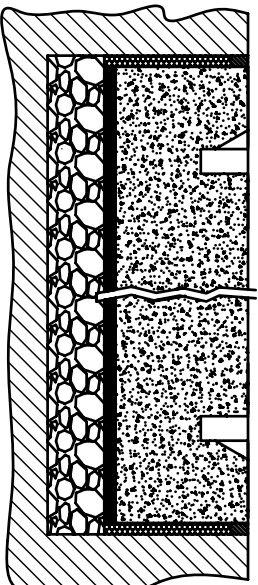

Dig out the hole of anchor bolts

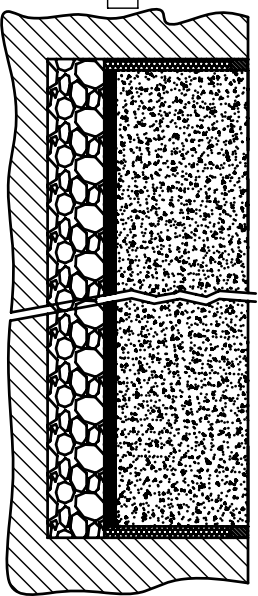

Put the oil-proof and anti-heat stripe on the other side, then fill up the cement(3000pci0
Harden time about 7~10 days

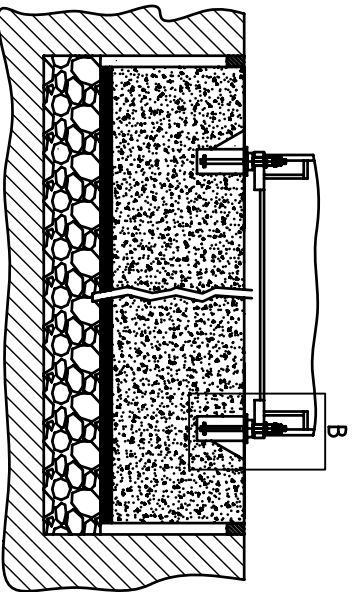

Put whole machine into the position

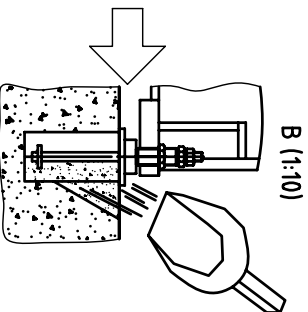

Fill up with 5000pci cement
harden time about 3~5 days

Leaderway Machinery Co. Ltd.

Scale

1:20

Drawing Name

PROCESS OF SETTING (地基施工圖)

Page

2/2

A4

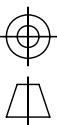

Drawn

jack

Date

96. 11. 20

Control

jack

Date

96. 11. 20

Draw No.

8150198B0 (全機型)

9	1	Nylon Hose	Ø4
8	1	Oil High-Pressure Hose	4180018100
7	1	Manifold-7	3987006A0
6	1	Manifold-9	3987005A0
5	1	Manifold-13	3987004A0
4	1	Flexible metal hose	4190060600
3	3	T type manifold	3 joint
2	1	Nylon Hose	Ø6
1	1	Lubricator	CEVB-03
		Item Qty	Description
			Spec.

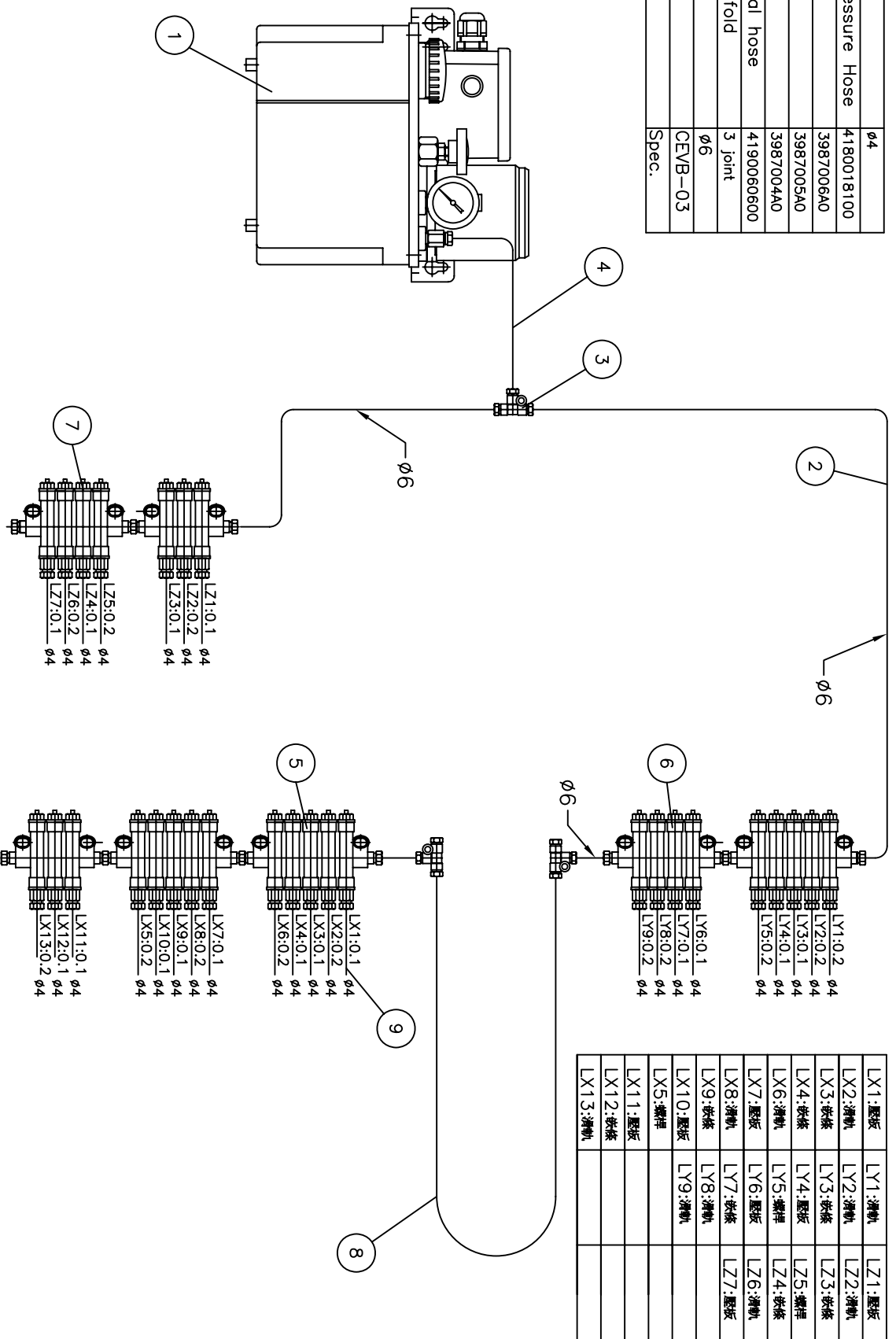

LX1: 壓板	LY1: 滑軌	LZ1: 壓板
LX2: 滑軌	LY2: 滑軌	LZ2: 滑軌
LX3: 嵌條	LY3: 嵌條	LZ3: 嵌條
LX4: 嵌條	LY4: 壓板	LZ4: 嵌條
LX6: 滑軌	LY5: 螺桿	LZ4: 嵌條
LX7: 壓板	LY6: 壓板	LZ6: 滑軌
LX8: 滑軌	LY7: 嵌條	LZ7: 壓板
LX9: 嵌條	LY8: 滑軌	
LX10: 壓板	LY9: 滑軌	
LX5: 螺桿		
LX11: 壓板		
LX12: 嵌條		
LX13: 滑軌		

Leaderway Machinery Co. Ltd.

潤滑油路配件組合圖
LUBRICATION ASSEMBLY DIAGRAM

Scale
1:5

Drawing Name

Drawn
Name
徐維駿

Page
1/1
A4

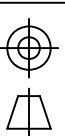

Control

審核

Date
97.06.27

Draw No.

8150059C0 (MV1100S-D)

9	1	Nylon Hose	ø4	
8	1	Oil High-Pressure Hose	4180018115	
7	1	Manifold-7	3987006A0	
6	1	Manifold-9	3987005A0	
5	1	Manifold-13	3987004A0	
4	1	Flexible metal hose	4190060600	
3	3	T type manifold	3 joint	
2	1	Nylon Hose	ø6	
1	1	Lubricator	CEVB-03	
		Item Qty	Description	Spec.

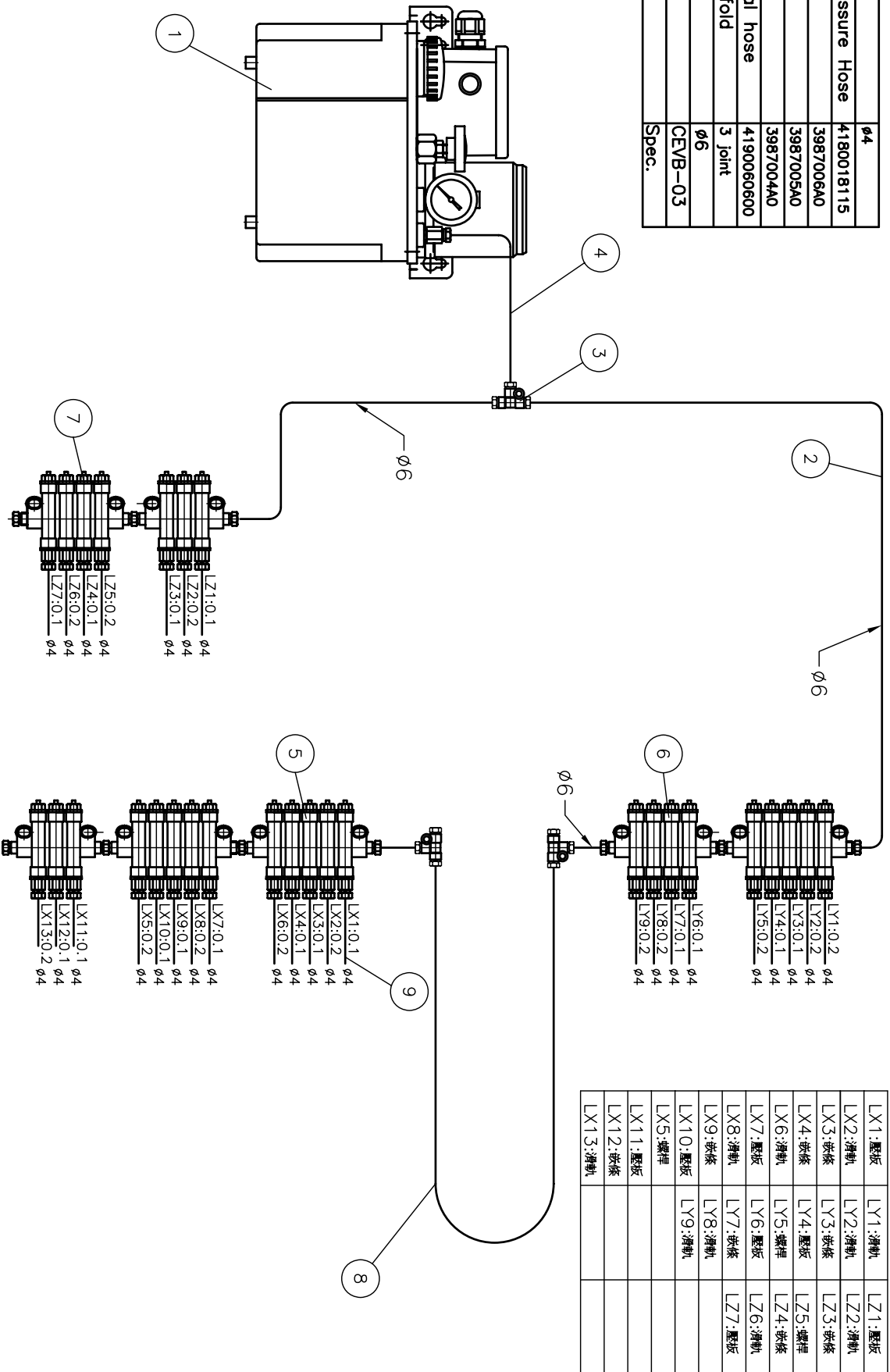

Leaderway Machinery Co. Ltd.

Scale 1:5
 Drawing Name 潤滑油路配件組合圖
 LUBRICATION ASSEMBLY DIAGRAM
 Page 1/1
 A4

Drawn 徐維駿
 Control 審核
 Date 97.06.27
 Unit yv, mm, dd
 Draw No. 8150098B0 (MV1300S-D)

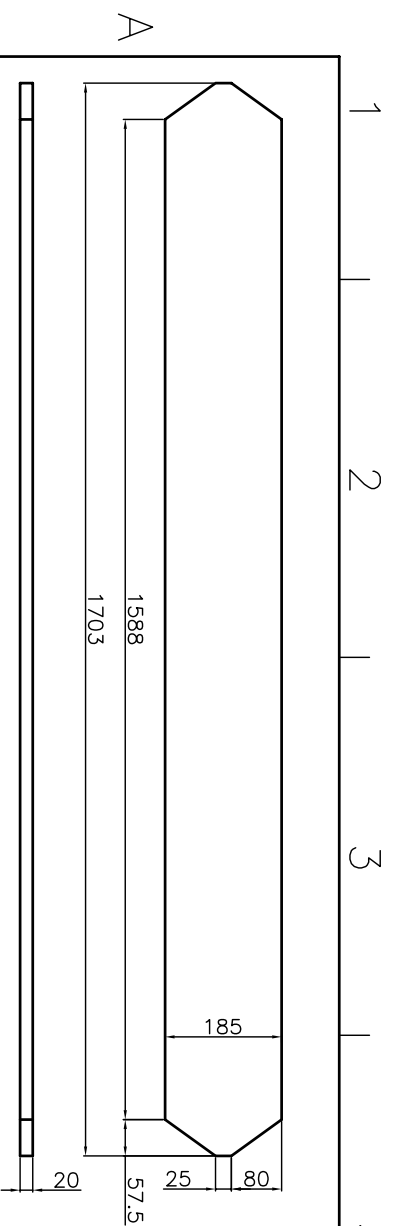

物件: A (比例 1 : 12)

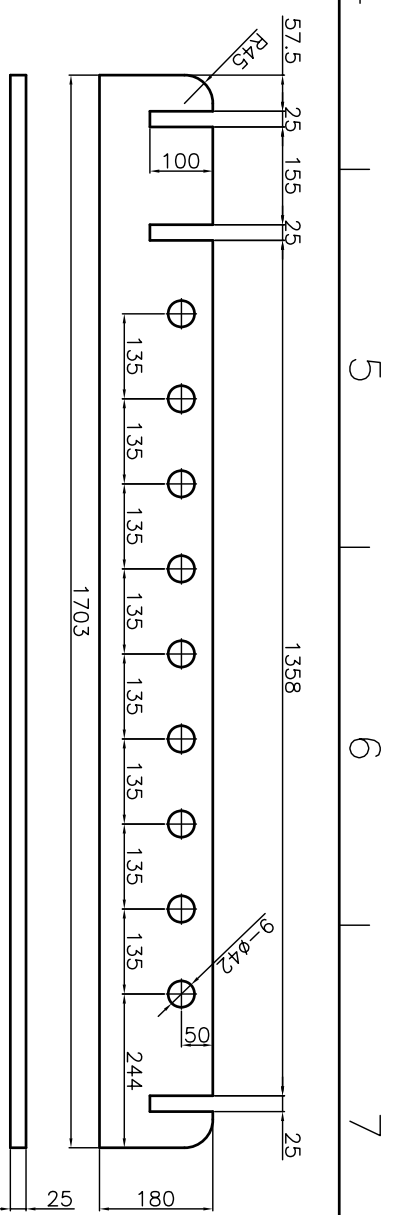

物件: B (比例 1 : 12)

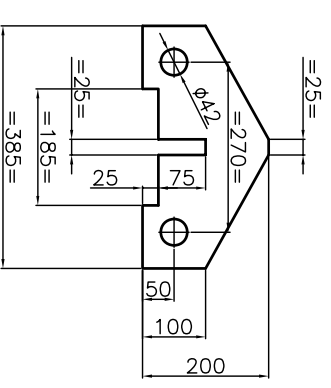

物件: A (比例 1 : 12)
數量: 3

吊車 (DRANE)

吊車 (DRANE)

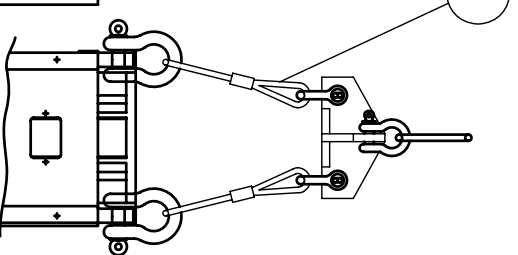
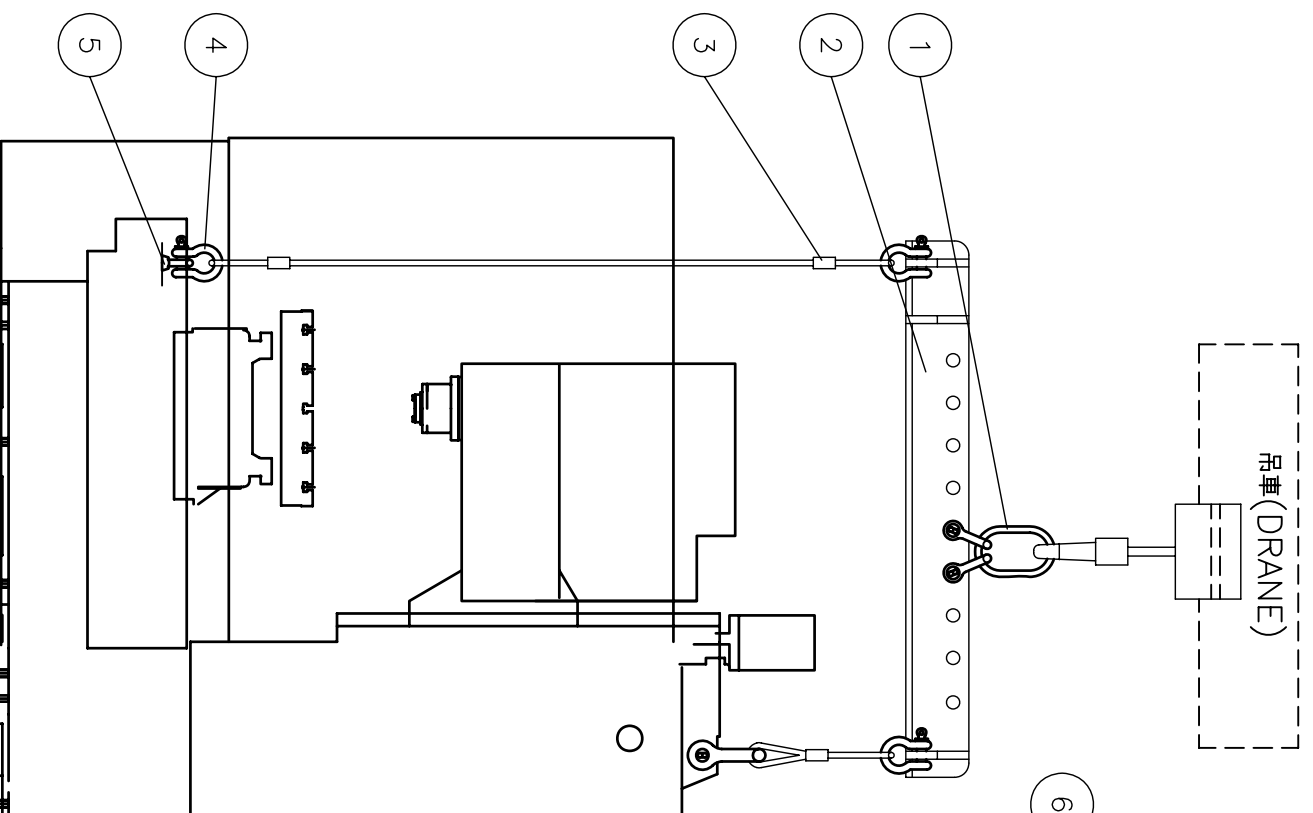
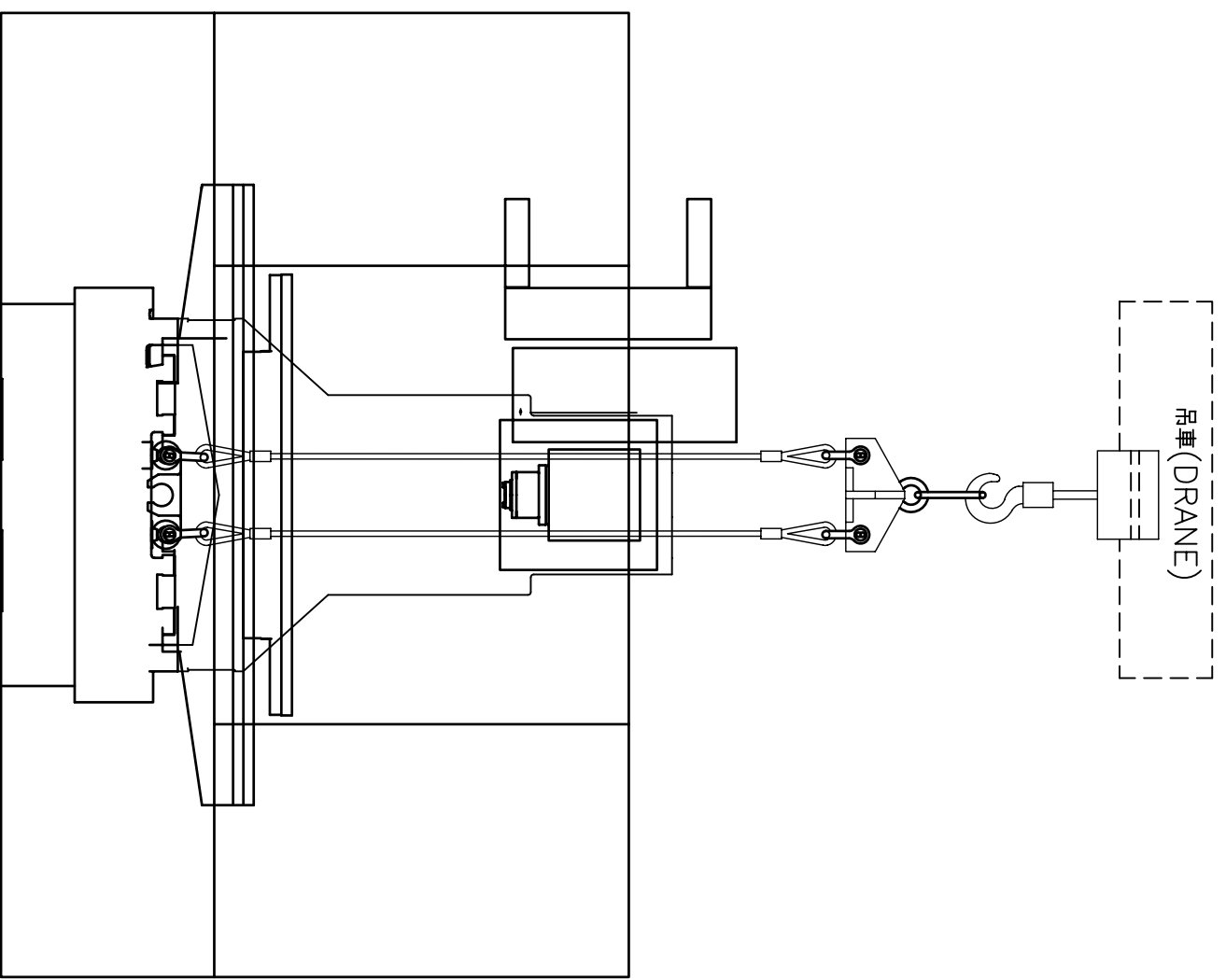

HANGING BRACKET

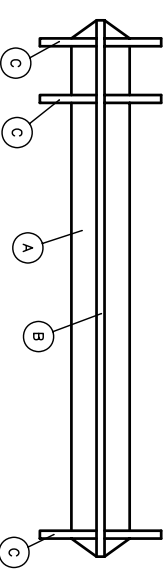

7	鋼線 (STEEL WIRE)	2	$\phi 18*480L$	
6	環首螺栓 (EYE BOLT)	2	M24	
5	吊環組 (HANGING SET)	1	1"	
4	鋼線 (STEEL WIRE)	2	$\phi 18*2180L$	
3	吊架組 (HANGING BRACKET)	1		
2	橢圓型鋼圈 (STEEL RING)	1	1"	
1	名稱 (PART NAME)	Q'TY	備註 (NOTE)	

Leaderway Machinery Co. Ltd.

Scale	Drawing Name		Page
1 : 24	MV1100 / MV1300 TRANSPORTATION DRAWING		1 / 1
Drawn	Name	Date	Draw No.
Control	審核	yy. mm. dd	
			815005500

E

E

D

C

B

A

1

2

3

4

5

6

7

8

F

E

D

C

B

A

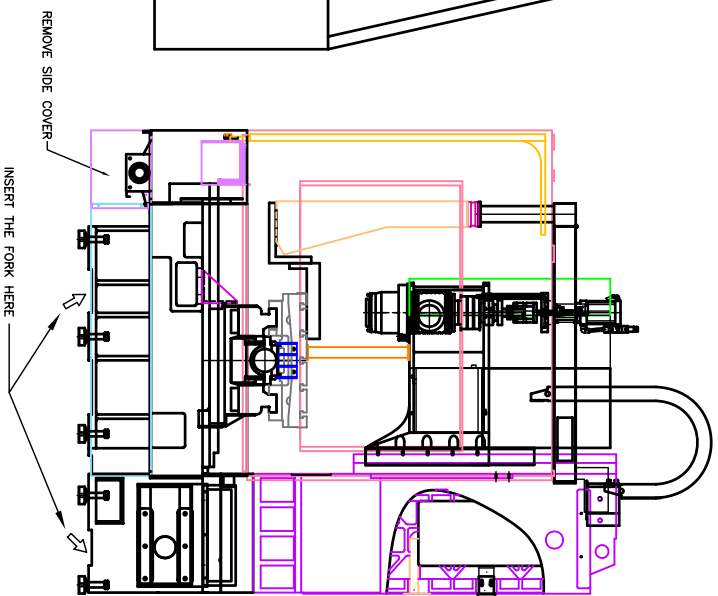
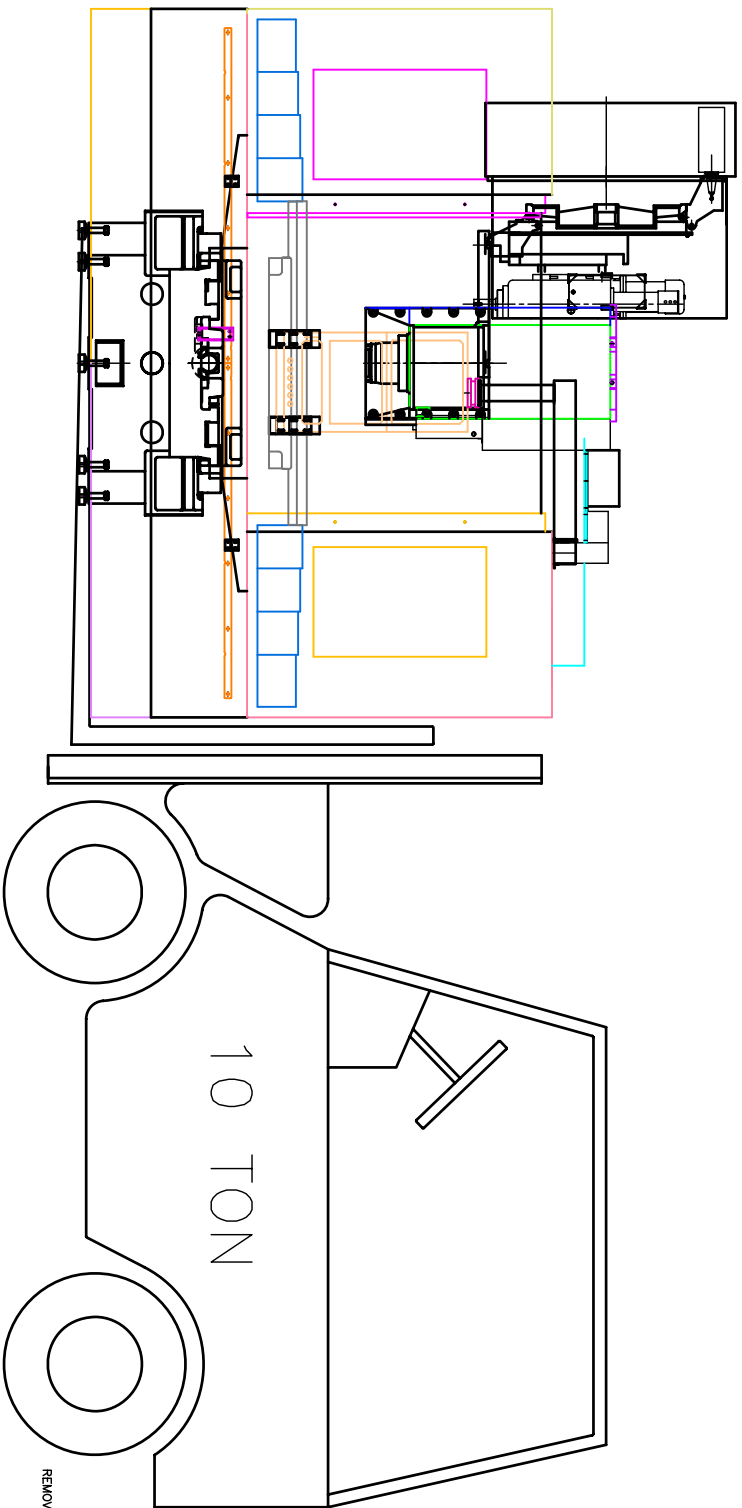

Leaderway Machinery Co. Ltd.

Scale
1:35

Drawing Name
TRANSPORTATION DRAWING OF FORKLIFT

Page
1/1

A4



Drawn	Name	Date
Control	徐维骏 审核	96.07.13 yy.mm.dd

Draw No.

8150095B0

台灣力得衛宇龍科技股份有限公司

*單階材料用量清單

製表日期: 99-08-17

第1頁

主件品號	序號	元件品號	品名 英文品名	規 格	月量
2F11004			主軸頭+立柱單元 SPINDLE HEAD + COLUMN UNIT	MV-1100S/MV-1300S	
	0013	3560002I0	立柱 COLUMN	1020\FC-25\3560002C2	1
	0022	3560003H0	主軸頭 SPINDLE HEAD	1010\FC-25\3560003C2	1
	0030	3560020B0	嵌條座 GIB BRACKET	1100\FC-25\3560020B2	1
	0040	3560025B0	嵌條座 GIB BRACKET	1100\FC-25\3560025B2	1
	0050	3560064A0	斜楔調整板 ADJUSTABLE WEDGE PAD	3200\SS41	3
	0060	3560076A0	嵌條壓板 PUSHING PAD, WEDGE	7120\SPCC	3
	0070	3560036B0	嵌條 GIB	1180\FC-25\取消B2、B3	2
	0080	3560133A0	嵌條 GIB	1180\FC-25	1
	0090	3560265A0	括屑片左(Z軸) LEFT SIDE WIPER(Z)	4380\NBR	2
	0100	3560266A0	括屑片右(Z軸) LEFT SIDE WIPER(Z)	4380\NBR	2
	0111	3500010B0	調整檔塊 ADJUSTABLE STOPPER	3140\SS41	2
	0120	3500014B0	碰塊座 DOG BRACKET	4140\AL(250m/m*3軌)	1
	0130	3500081A0	碰塊 DOG	3140\SS41(42m/m)	2
	0140	3500082B0	碰塊座 DOG BRACKET	4140\AL(125m/m*3軌)	1
	0190	3540007A0	碰塊 DOG	4140\AL 外購65L	1
	0200	3560049C0	Z軸下摺動罩 LOWER TELESCOPIC COVER, Z	7400\SPCCZ	1
	0211	3560381C0	聯動管支架 CONDUIT BRACKET	7210\SPCC	1
	0220	3560092A0	Z軸微動開關座 MICRO SWITCH BRACKET, Z AXIS	3160\SS41	1
	0230	3560093C0	聯動管支架 CONDUIT BRACKET	7210\SPCC	1
	0240	3560140A0	Z軸下支架 LOWER BRACKET (Z)	7210\SPCC	2
	0250	3560188B0	摺動罩墊片 TELESCOPIC COVER PAD	7210\SPCC	1
	0260	3500049A0	機頭側罩蓋板 SIDE COVER	7510\SPCC	1
	0270	3560091A0	主軸頭蓋板 SPINDLE HEAD COVER	7510\SPCC	1
	0280	3560096A0	主軸頭左護罩 LEFT COVER, SPINDLE HEAD	7500\SPCC	1
	0290	3560099B0	主軸頭右蓋板 RIGHT COVER, SPINDLE HEAD	7510\SPCC	1
	0310	3560135A0	主軸頭側蓋板 SIDE COVER, SPINDLE HEADSTOCK	7510\SPCC	2
	0322	3560594C0	蓋板固定座 FIXED BRACKET OF COVER	7210\SPCC	1
	0331	3560292B0	主軸頭側蓋板 SIDE COVER, SPINDLE HEADSTOCK	7510\SPCC	1
	0345	3560595D0	主軸頭護罩 SPINDLE HEADSTOCK ENCLOSURE	7500\SPCC	1
	0351	3990144A0	刀具釋放指示牌 NAME PLATE	4350\AL	1

<續下頁>

台灣力得衛宇龍科技股份有限公司

*單階材料用量清單

製表日期: 99-08-17

第2頁

主件品號	序號	元件品號	品名 英文品名	規 格	月量
2F11004	0370	4640800030	方形連動管組 WIRE CONDUIT	KY-CDCBS65.1-45x75-30P-364	1
	0380	4800143204	微動開關 MICRO SWITCH	BNS819-B02-D12-61-12-10BALLU	1
	0400	3570058A0	蓋板 COVER	7180\SPCC	1
	0450	3560502A0	左側蓋板 LEFT SIDE COVER	7510\SPCC	1
	0461	3560308D0	立柱後蓋板 REAR COVER, COLUMN	7510\SPCC	1
	0470	3560323A0	立柱蓋板 COLUMN COVER	7510\SPCC	3
	0491	4210550003	總流量控制組 COOLANT NOZZLE MANIFOLD	JTM-01控制組\5/8"插心	1
	0501	3560321B0	近接開關座 PROXIMITY SWITCH BRACKET	7160\SPCC	1
	0510	3580279A0	機頭側壓克力 ACRYLIC PLATE, SPINDLE HEAD	4360\ACRY	1

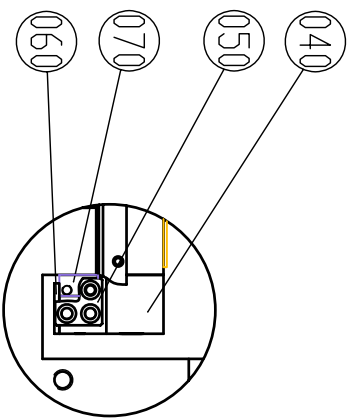

A视图 2:9

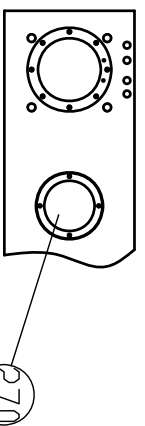
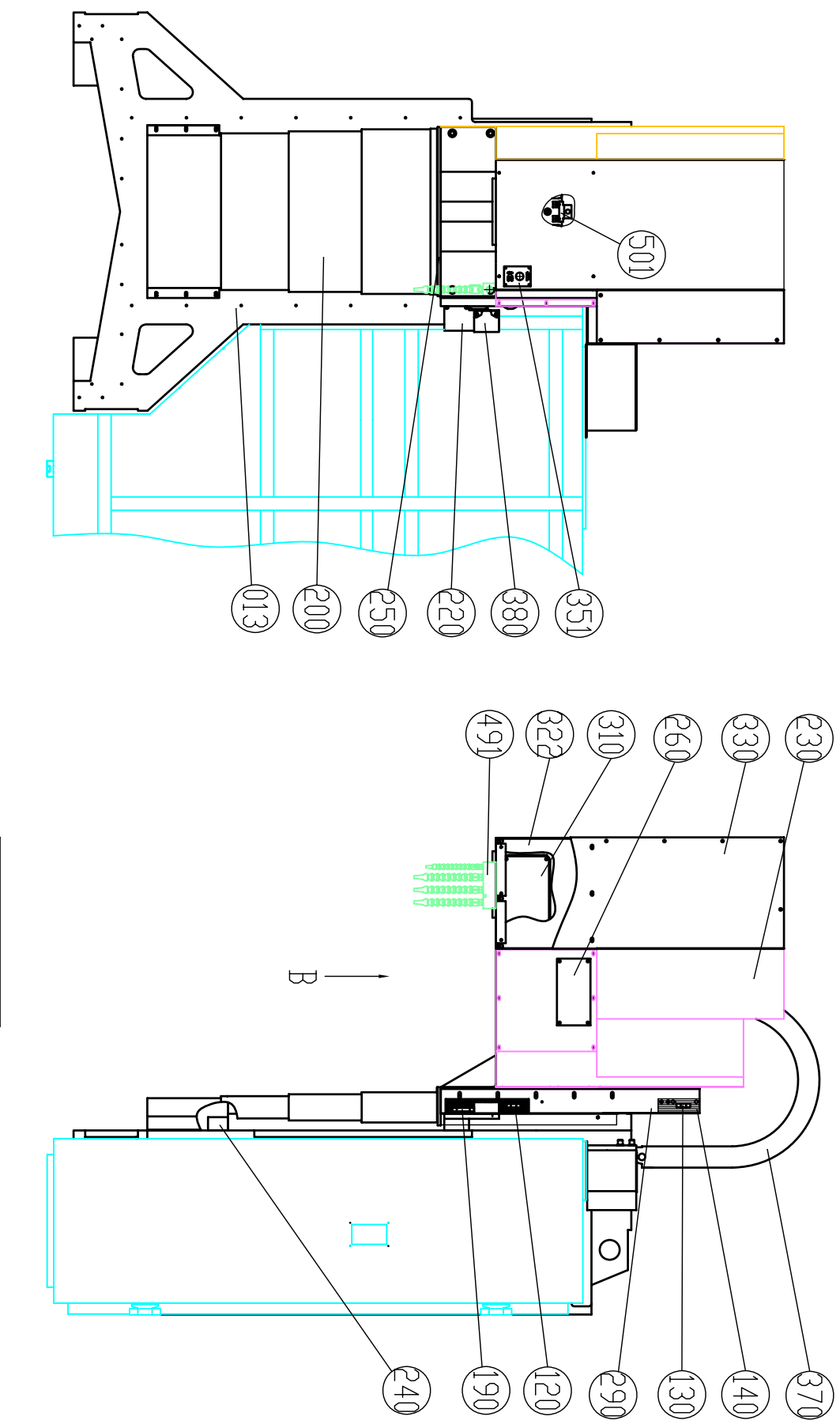
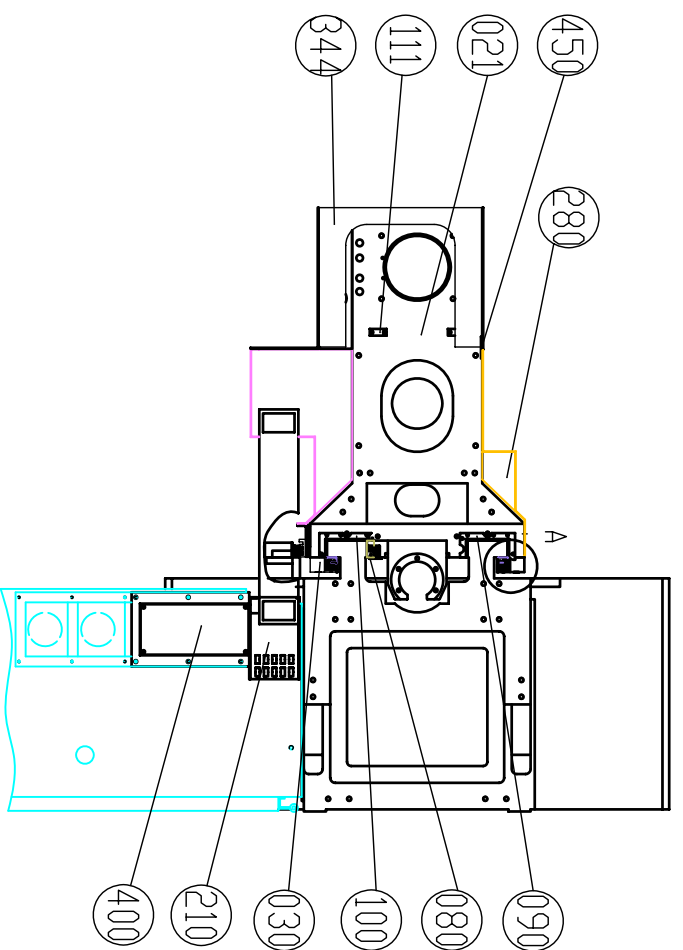

B视图

MV-1100S\MV-1300S

Leaderway Machinery Co. Ltd.

Scale		Drawing Name		Page	
1:18		主軸頭 + 立柱單元 SPINDLE HEAD + COLUMN UNIT		1/1	
Drawn		Date		Draw No.	
洪文昇		97.06.04		8120109B0 (2F11004)	
Control					

A3

台灣力得衛宇龍科技股份有限公司

*單階材料用量清單

製表日期: 99-08-17

第1頁

主件品號	序號	元件品號	品名 英文品名	規 格	月量
2F11025			主軸頭+立柱單元 SPINDLE HEAD + COLUMN UNIT	MV-1100S/MV-1300S+Gear Box	
	0011	3560002I0	立柱 COLUMN	1020\FC-25\3560002C2	1
	0022	3560003H0	主軸頭 SPINDLE HEAD	1010\FC-25\3560003C2	1
	0030	3560020B0	嵌條座 GIB BRACKET	1100\FC-25\3560020B2	1
	0040	3560025B0	嵌條座 GIB BRACKET	1100\FC-25\3560025B2	1
	0050	3560064A0	斜楔調整板 ADJUSTABLE WEDGE PAD	3200\SS41	3
	0060	3560076A0	嵌條壓板 PUSHING PAD, WEDGE	7120\SPCC	3
	0070	3560036B0	嵌條 GIB	1180\FC-25\取消B2、B3	2
	0080	3560133A0	嵌條 GIB	1180\FC-25	1
	0090	3560265A0	括屑片左(Z軸) LEFT SIDE WIPER(Z)	4380\NBR	2
	0100	3560266A0	括屑片右(Z軸) LEFT SIDE WIPER(Z)	4380\NBR	2
	0110	3500010B0	調整檔塊 ADJUSTABLE STOPPER	3140\SS41	2
	0120	3500014B0	碰塊座 DOG BRACKET	4140\AL(250m/m*3軌)	1
	0130	3500081A0	碰塊 DOG	3140\SS41(42m/m)	2
	0140	3500082B0	碰塊座 DOG BRACKET	4140\AL(125m/m*3軌)	1
	0190	3540007A0	碰塊 DOG	4140\AL 外購65L	1
	0200	3560049C0	Z軸下摺動罩 LOWER TELESCOPIC COVER, Z	7400\SPCCZ	1
	0211	3560381C0	聯動管支架 CONDUIT BRACKET	7210\SPCC	1
	0220	3560092A0	Z軸微動開關座 MICRO SWITCH BRACKET, Z AXIS	3160\SS41	1
	0230	3560598A0	聯動管支架 CONDUIT BRACKET	7210\SPCC	1
	0240	3560140A0	Z軸下支架 LOWER BRACKET (Z)	7210\SPCC	2
	0250	3560188B0	摺動罩墊片 TELESCOPIC COVER PAD	7210\SPCC	1
	0261	3560599B0	主軸頭側蓋板 SIDE COVER, SPINDLE HEADSTOCK	7510\SPCC	1
	0270	3560091A0	主軸頭蓋板 SPINDLE HEAD COVER	7510\SPCC	1
	0280	3560096A0	主軸頭左護罩 LEFT COVER, SPINDLE HEAD	7500\SPCC	1
	0290	3560099B0	主軸頭右蓋板 RIGHT COVER, SPINDLE HEAD	7510\SPCC	1
	0310	3560135A0	主軸頭側蓋板 SIDE COVER, SPINDLE HEADSTOCK	7510\SPCC	2
	0332	3560594C0	蓋板固定座 FIXED BRACKET OF COVER	7210\SPCC	1
	0343	3560595D0	主軸頭護罩 SPINDLE HEADSTOCK ENCLOSURE	7500\SPCC	1
	0351	3990144A0	刀具釋放指示牌 NAME PLATE	4350\AL	1
	0370	4640800030	方形連動管組 WIRE CONDUIT	KY-CDCBS65.1-45x75-30P-364	1

<續下頁>

台灣力得衛宇龍科技股份有限公司

*單階材料用量清單

製表日期: 99-08-17

第2頁

主件品號	序號	元件品號	品名 英文品名	規 格	月量
2F11025	0380	4800143204	微動開關 MICRO SWITCH	BNS819-B02-D12-61-12-10BALLU	1
	0400	3570058A0	蓋板 COVER	7180\SPCC	1
	0450	3560502A0	左側蓋板 LEFT SIDE COVER	7510\SPCC	1
	0460	3560308D0	立柱後蓋板 REAR COVER, COLUMN	7510\SPCC	1
	0470	3560323A0	立柱蓋板 COLUMN COVER	7510\SPCC	3
	0481	4210550003	總流量控制組 COOLANT NOZZLE MANIFOLD	JTM-01控制組\5/8"插心	1
	0491	3560321B0	近接開關座 PROXIMITY SWITCH BRACKET	7160\SPCC	1
	0500	3580279A0	機頭側壓克力 ACRYLIC PLATE, SPINDLE HEAD	4360\ACRY	1

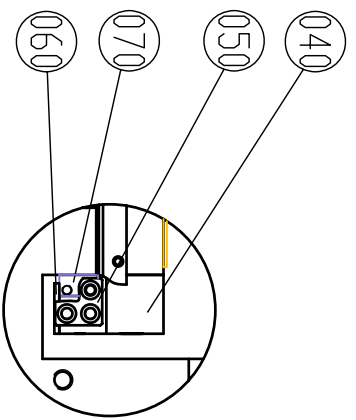

A 視圖 2:9

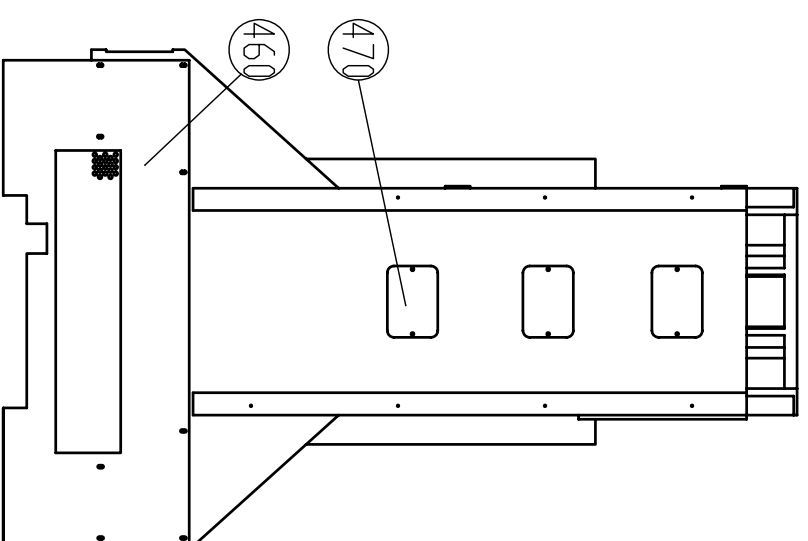
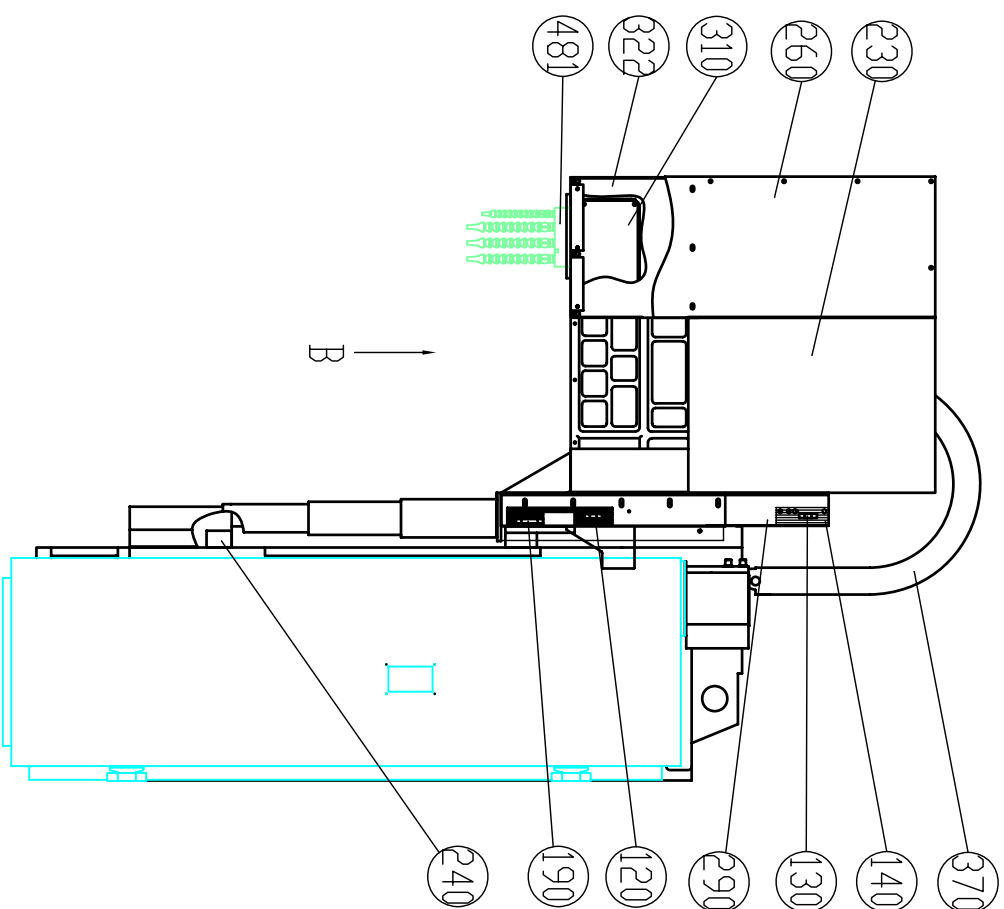
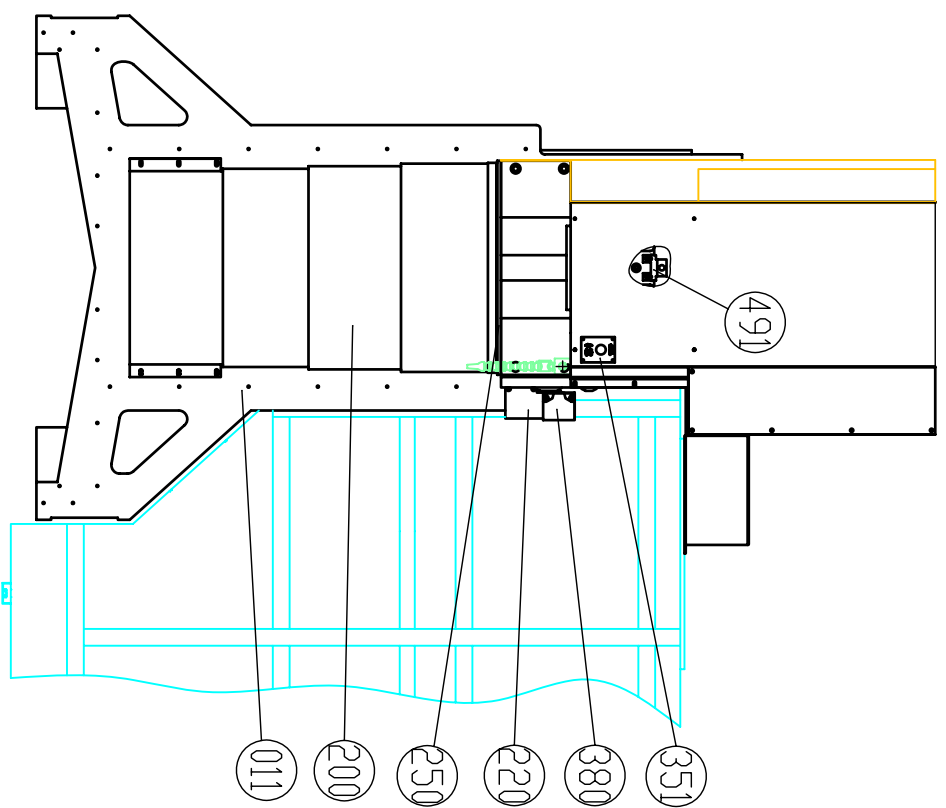
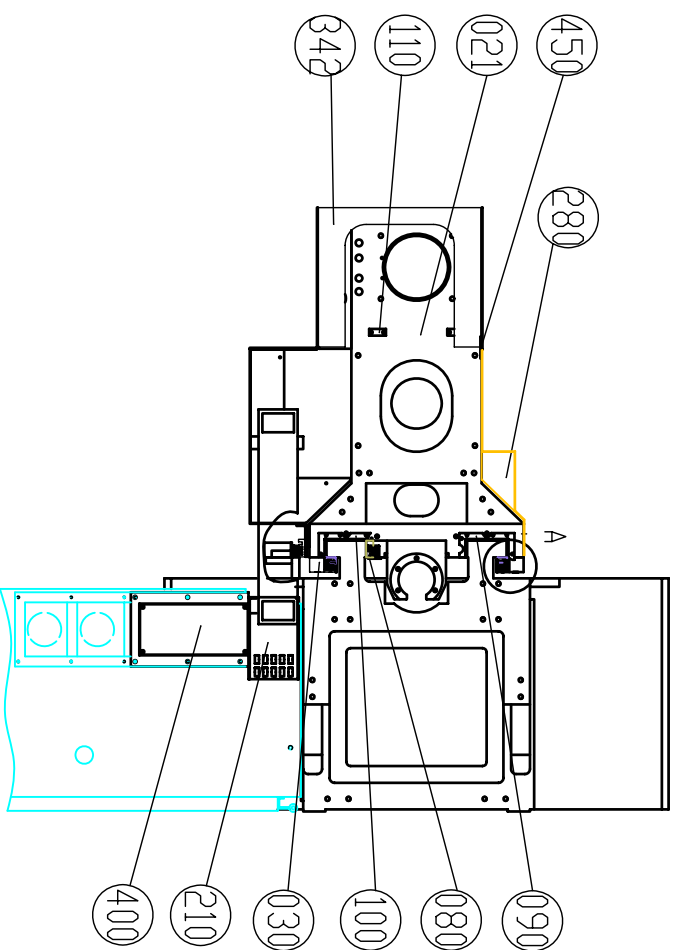

MV-1100S\MV-1300S+Gear Box

Leaderway Machinery Co. Ltd.

Scale		Drawing Name		Page	
1:18		主軸頭 + 立柱單元 SPINDLE HEAD + COLUMN UNIT		1/1	
Drawn		Date		Draw No.	
Control		洪文昇		8120394A0 (2F11025)	
		97.06.09			

B 視圖

270

台灣力得衛宇龍科技股份有限公司

*單階材料用量清單

製表日期: 99-08-17

第1頁

主件品號	序號	元件品號	品名 英文品名	規 格	月量
2F11005			主軸頭+立柱單元 SPINDLE HEAD + COLUMN UNIT	MV1100D/MV1300D/ ϕ 40	
	0011	3500010B0	調整檔塊 ADJUSTABLE STOPPER	3140\SS41	2
	0020	3500014B0	碰塊座 DOG BRACKET	4140\AL(250m/m*3軌)	1
	0030	3500081A0	碰塊 DOG	3140\SS41(42m/m)	2
	0040	3500082B0	碰塊座 DOG BRACKET	4140\AL(125m/m*3軌)	1
	0090	3540007A0	碰塊 DOG	4140\AL 外購65L	1
	0103	3560002I0	立柱 COLUMN	1020\FC-25\3560002C2	1
	0110	3560049C0	Z軸下摺動罩 LOWER TELESCOPIC COVER, Z	7400\SPCCZ	1
	0120	3560064A0	斜楔調整板 ADJUSTABLE WEDGE PAD	3200\SS41	3
	0140	3560092A0	Z軸微動開關座 MICRO SWITCH BRACKET, Z AXIS	3160\SS41	1
	0150	3560099B0	主軸頭右蓋板 RIGHT COVER, SPINDLE HEAD	7510\SPCC	1
	0170	3560140A0	Z軸下支架 LOWER BRACKET (Z)	7210\SPCC	2
	0180	3560188B0	摺動罩墊片 TELESCOPIC COVER PAD	7210\SPCC	1
	0190	3560265A0	括屑片左(Z軸) LEFT SIDE WIPER(Z)	4380\NBR	2
	0200	3560266A0	括屑片右(Z軸) LEFT SIDE WIPER(Z)	4380\NBR	2
	0212	3560375E0	主軸頭 SPINDLE HEAD	1010\FC-30\3570020B2	1
	0222	3560381C0	聯動管支架 CONDUIT BRACKET	7210\SPCC	1
	0230	3570012B0	主軸頭左嵌條座 LEFT SIDE GIB BRACKET	1100\FC-25\3570012A2	1
	0240	3570013B0	主軸頭右嵌條座 RIGHT SIDE GIB BRACKET	1100\FC-25\3570013A2	1
	0250	3570014B0	嵌條 GIB	1180\FC-25	2
	0261	3570015B0	嵌條(側向) GIB	1180\FC-25	1
	0271	3570016B0	側面嵌條檔片 STOPPING PAD, SIDE GIB	7180\SPCC	6
	0280	3570017B0	孔蓋 HOLE CAP	3230\S45C	2
	0293	3570018F0	右側支架 RIGHT SIDE SUPPORTER	7210\SPCC	1
	0303	3570019E0	主軸頭前蓋板 FRONT COVER, SPINDLE HEAD	7510\SPCC	1
	0311	3570021D0	主軸頭右側蓋板 RIGHT COVER, SPINDLE HEAD	7510\SPCC	1
	0320	3570022B0	主軸頭左側蓋板 LEFT COVER, SPINDLE HEAD	7510\SPCC	1
	0330	3570023B0	主軸頭連動管支架 CONDUIT BRACKET	7210\SPCC	1
	0340	4060020110	O型環 O RING	G110	2
	0370	4640800030	方形連動管組 WIRE CONDUIT	KY-CDCBS65.1-45x75-30P-364	1
	0380	4800143204	微動開關 MICRO SWITCH	BNS819-B02-D12-61-12-10BALLU	1

<續下頁>

台灣力得衛宇龍科技股份有限公司

*單階材料用量清單

製表日期: 99-08-17

第2頁

主件品號	序號	元件品號	品名 英文品名	規 格	月量
2F11005	0390	3570058A0	蓋板 COVER	7180\SPCC	1
	0441	3990144A0	刀具釋放指示牌 NAME PLATE	4350\AL	1
	0450	3560323A0	立柱蓋板 COLUMN COVER	7510\SPCC	3
	0460	3560371B0	近接開關座 PROXIMITY SWITCH BRACKET	7160\SPCC	1
	0470	3560308D0	立柱後蓋板 REAR COVER, COLUMN	7510\SPCC	1
	0481	4210550003	總流量控制組 COOLANT NOZZLE MANIFOLD	JTM-01控制組\5/8"插心	1
	0490	3580279A0	機頭側壓克力 ACRYLIC PLATE, SPINDLE HEAD	4360\ACRY	1

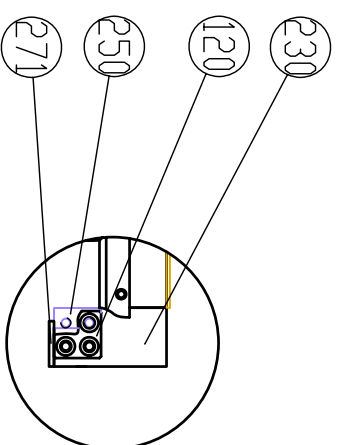

A 縮圖 2:1

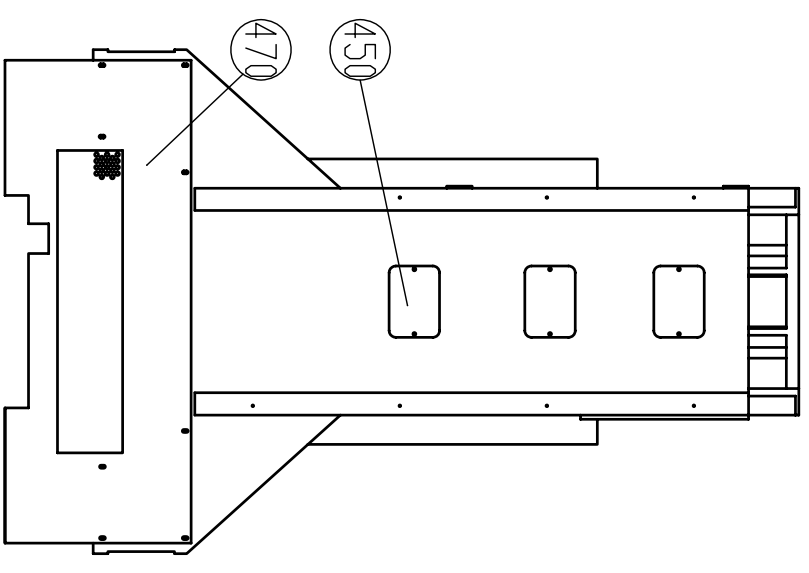
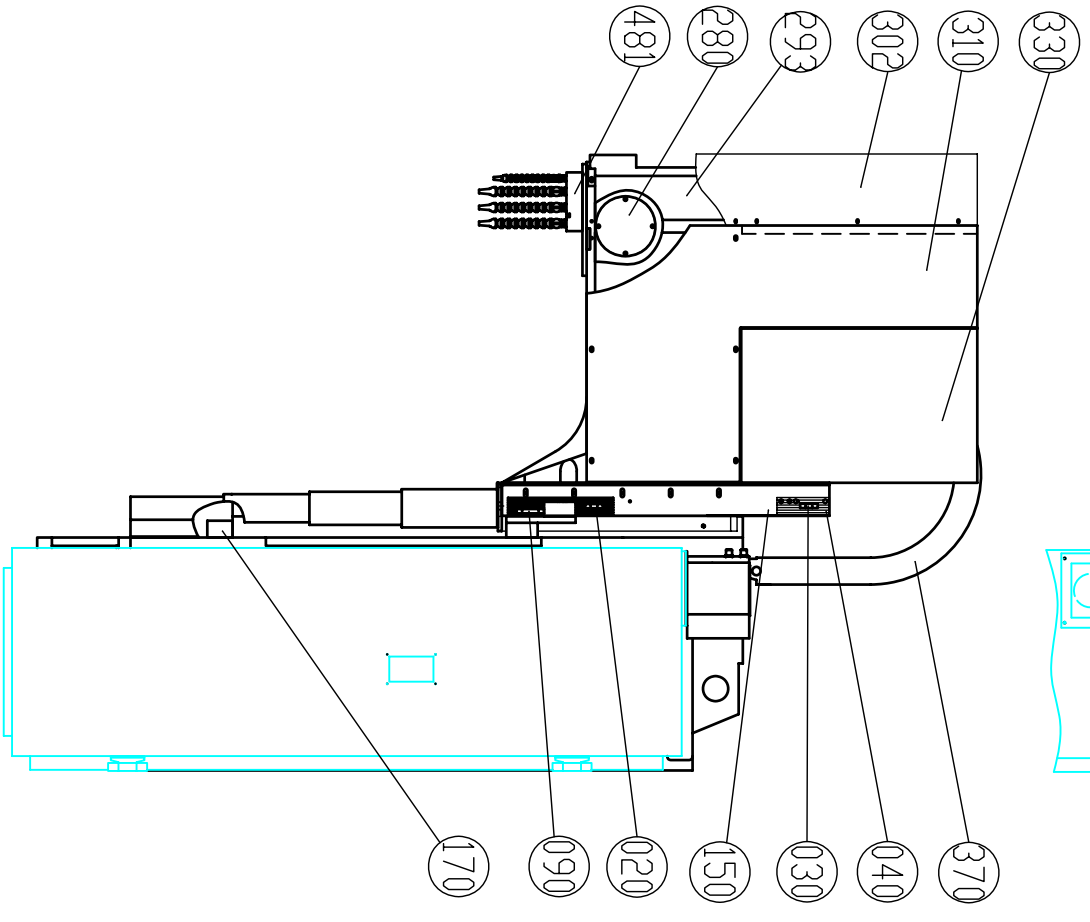
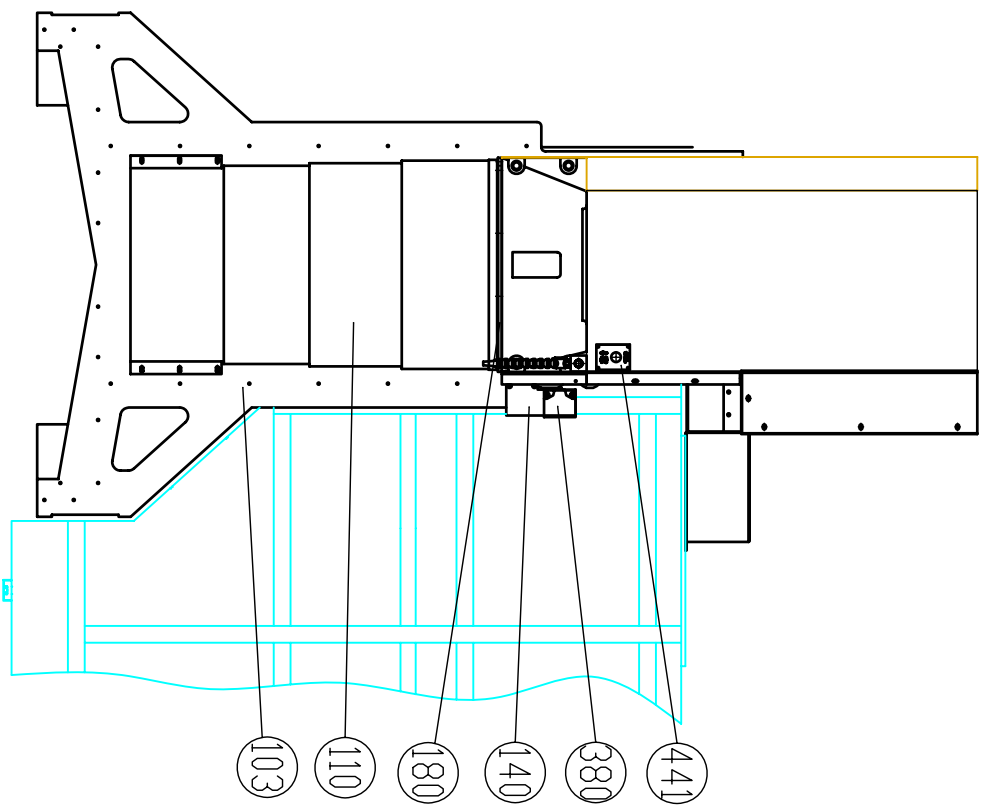
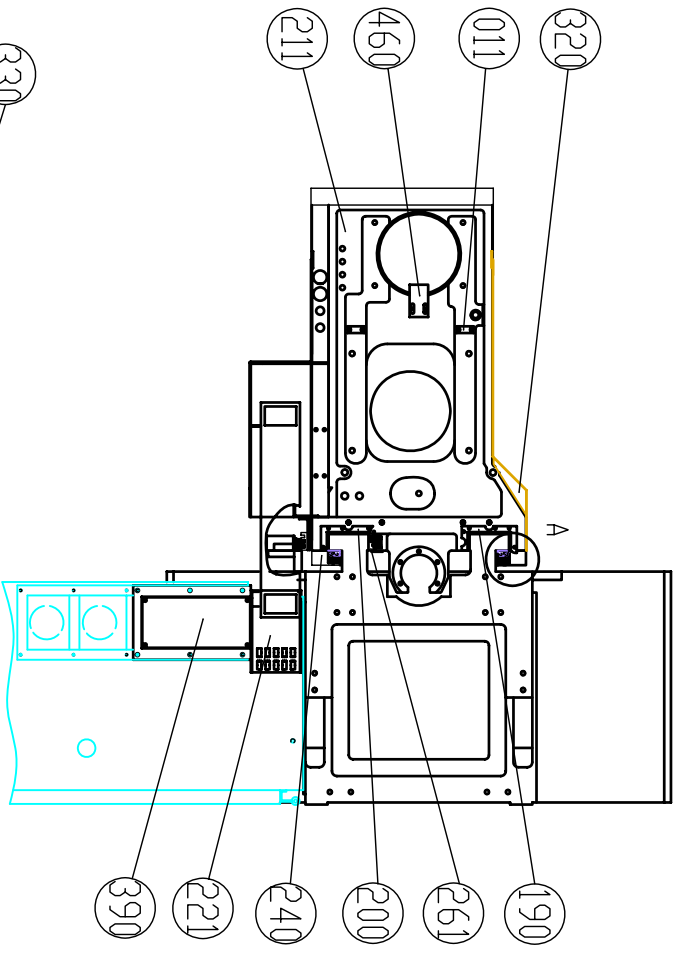

MV-1100D \ MV-1300D

Leaderway Machinery Co. Ltd.

Scale		Drawing Name		Page	
1:18		主軸頭 + 立柱單元 SPINDLE HEAD + COLUMN UNIT		1/1	
Drawn		Date		Draw No.	
Control		洪文昇		8120152B0(2F11005)	
		97.05.27			

A3

台灣力得衛宇龍科技股份有限公司

*單階材料用量清單

製表日期: 99-08-17

第1頁

主件品號	序號	元件品號	品名 英文品名	規 格	月量
2F11026			主軸頭+立柱單元 SPINDLE HEAD + COLUMN UNIT	MV1100D/1300D+Gear Box(2K25C	
	0010	3500010B0	調整檔塊 ADJUSTABLE STOPPER	3140\SS41	2
	0020	3500014B0	碰塊座 DOG BRACKET	4140\AL(250m/m*3軌)	1
	0030	3500081A0	碰塊 DOG	3140\SS41(42m/m)	2
	0040	3500082B0	碰塊座 DOG BRACKET	4140\AL(125m/m*3軌)	1
	0080	3540007A0	碰塊 DOG	4140\AL 外購65L	1
	0091	3560002I0	立柱 COLUMN	1020\FC-25\3560002C2	1
	0100	3560049C0	Z軸下摺動罩 LOWER TELESCOPIC COVER, Z	7400\SPCCZ	1
	0110	3560064A0	斜楔調整板 ADJUSTABLE WEDGE PAD	3200\SS41	3
	0120	3560092A0	Z軸微動開關座 MICRO SWITCH BRACKET, Z AXIS	3160\SS41	1
	0130	3560099B0	主軸頭右蓋板 RIGHT COVER, SPINDLE HEAD	7510\SPCC	1
	0140	3560140A0	Z軸下支架 LOWER BRACKET (Z)	7210\SPCC	2
	0150	3560188B0	摺動罩墊片 TELESCOPIC COVER PAD	7210\SPCC	1
	0160	3560265A0	括屑片左(Z軸) LEFT SIDE WIPER(Z)	4380\NBR	2
	0170	3560266A0	括屑片右(Z軸) LEFT SIDE WIPER(Z)	4380\NBR	2
	0182	3560375E0	主軸頭 SPINDLE HEAD	1010\FC-30\3570020B2	1
	0191	3560381C0	聯動管支架 CONDUIT BRACKET	7210\SPCC	1
	0200	3570012B0	主軸頭左嵌條座 LEFT SIDE GIB BRACKET	1100\FC-25\3570012A2	1
	0210	3570013B0	主軸頭右嵌條座 RIGHT SIDE GIB BRACKET	1100\FC-25\3570013A2	1
	0220	3570014B0	嵌條 GIB	1180\FC-25	2
	0230	3570015B0	嵌條(側向) GIB	1180\FC-25	1
	0241	3570016B0	側面嵌條檔片 STOPPING PAD, SIDE GIB	7180\SPCC	6
	0250	3570017B0	孔蓋 HOLE CAP	3230\S45C	2
	0262	3570019E0	主軸頭前蓋板 FRONT COVER, SPINDLE HEAD	7510\SPCC	1
	0270	3570022B0	主軸頭左側蓋板 LEFT COVER, SPINDLE HEAD	7510\SPCC	1
	0280	4060020110	O型環 O RING	G110	2
	0290	4640800030	方形連動管組 WIRE CONDUIT	KY-CDCBS65.1-45x75-30P-364	1
	0300	4800143204	微動開關 MICRO SWITCH	BNS819-B02-D12-61-12-10BALLU	1
	0310	3570058A0	蓋板 COVER	7180\SPCC	1
	0321	3990144A0	刀具釋放指示牌 NAME PLATE	4350\AL	1
	0330	3560323A0	立柱蓋板 COLUMN COVER	7510\SPCC	3

<續下頁>

台灣力得衛宇龍科技股份有限公司

*單階材料用量清單

製表日期: 99-08-17

第2頁

主件品號	序號	元件品號	品名 英文品名	規 格	月量
2F11026	0340	3560371B0	近接開關座 PROXIMITY SWITCH BRACKET	7160\SPCC	1
	0350	3560308D0	立柱後蓋板 REAR COVER, COLUMN	7510\SPCC	1
	0362	3570132D0	右側支架 RIGHT SIDE SUPPORTER	7210\SPCC	1
	0370	3570133B0	連動管支架(主軸頭) CONDUIT BRACKET	7210\SPCC	1
	0381	3570134C0	主軸頭右側蓋板 RIGHT COVER, SPINDLE HEAD	7510\SPCC	1
	0391	4210550003	總流量控制組 COOLANT NOZZLE MANIFOLD	JTM-01控制組\5/8"插心	1
	0400	3580279A0	機頭側壓克力 ACRYLIC PLATE, SPINDLE HEAD	4360\ACRY	1

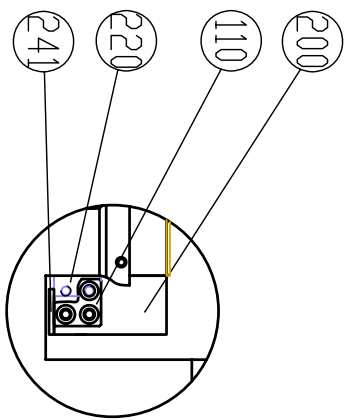

A視圖 2:9

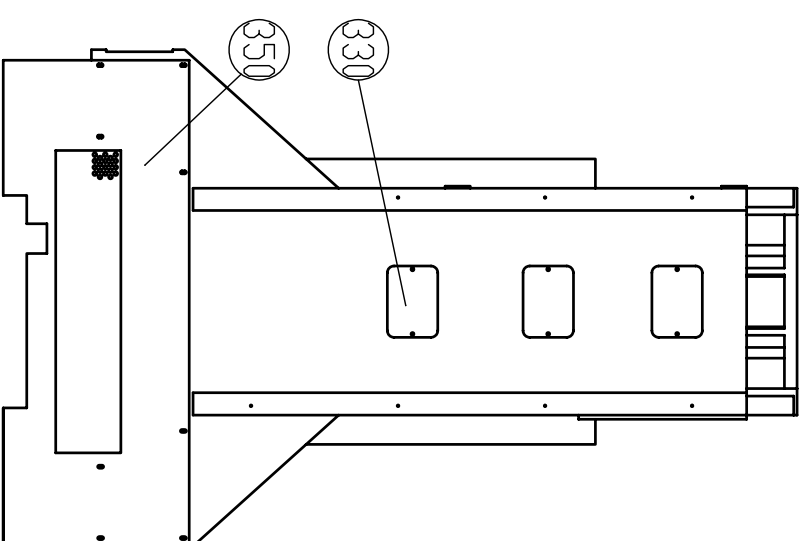
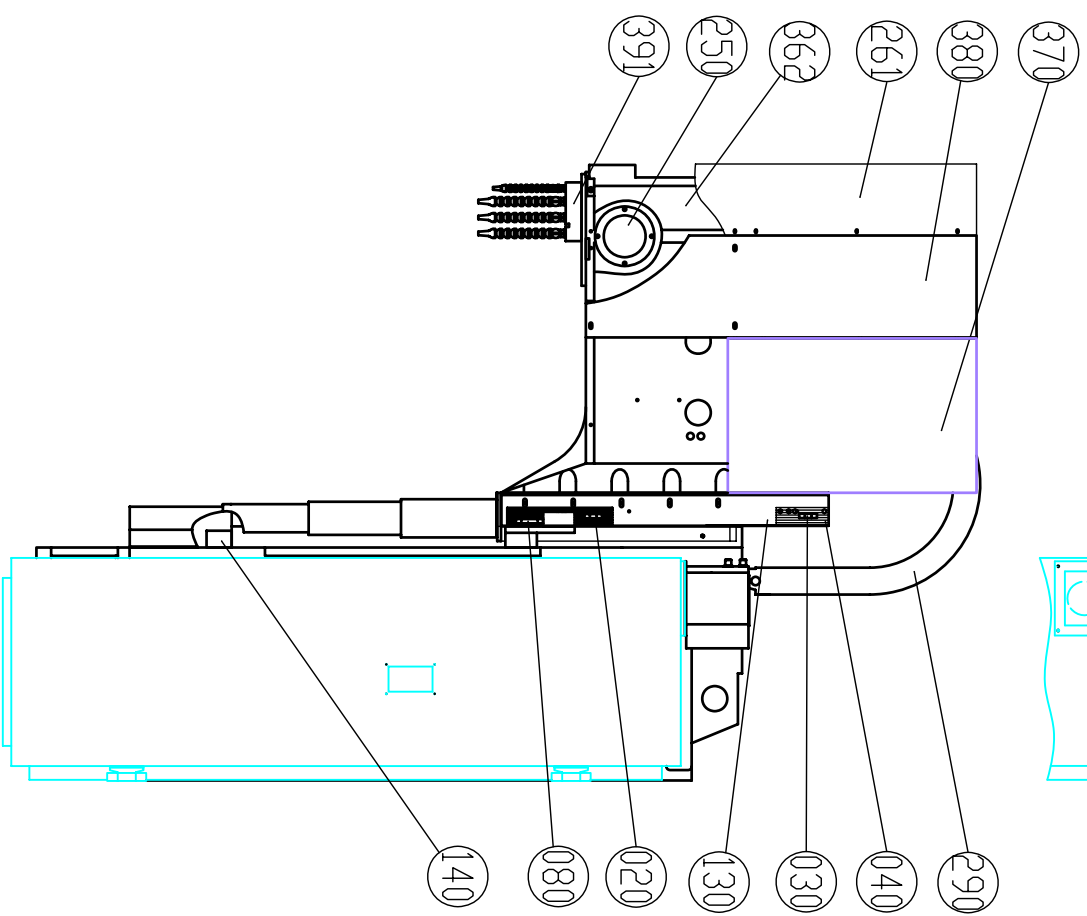
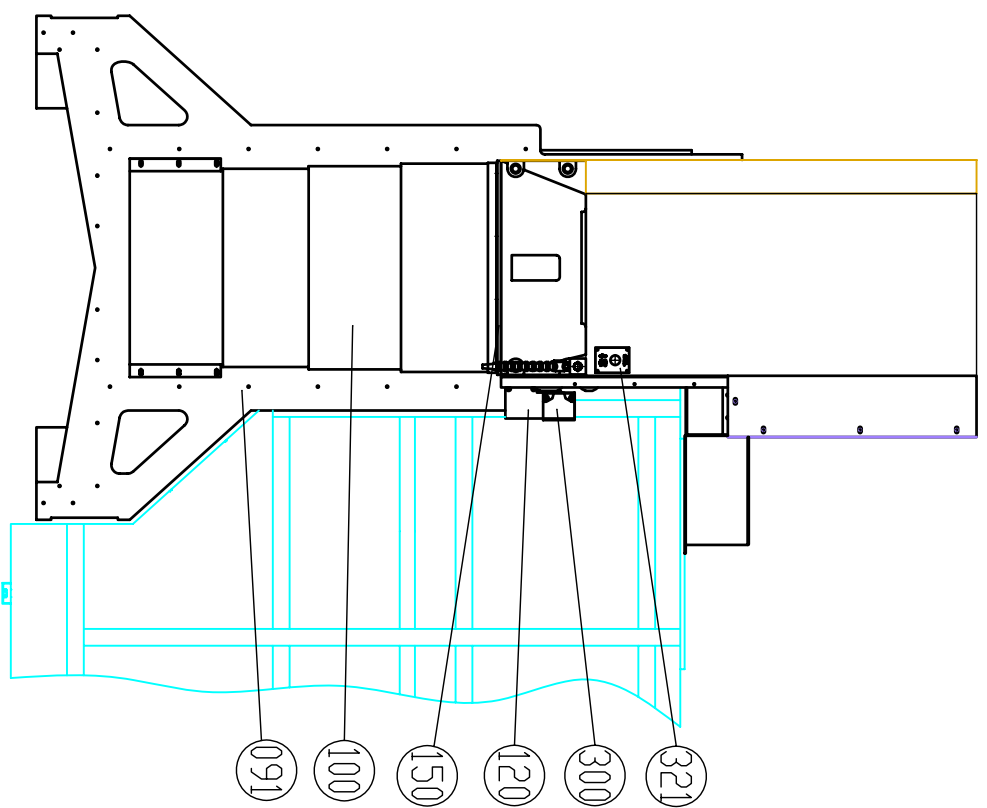
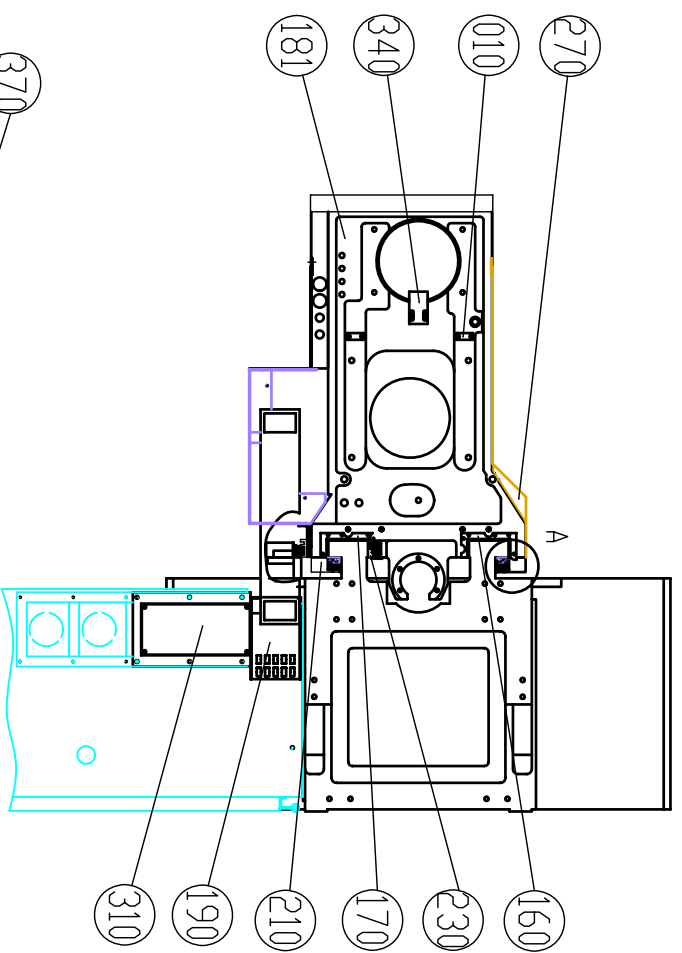

MV-1100D\MV-1300DD+Gear Box

Leaderway Machinery Co. Ltd.

Scale		Drawing Name		Page	
1:18		主軸頭 + 立柱單元 SPINDLE HEAD + COLUMN UNIT		1/1	
Drawn		Date		Draw No.	
Control		洪文昇		8120302B0(2F11026)	
		97.05.27			

A3

台灣力得衛宇龍科技股份有限公司

*單階材料用量清單

製表日期: 97-06-13

第1頁

主件品號	序號	元件品號	品名 英文品名	規 格	用量
2F13004			底座+鞍座+工作台單元 BASE + SADDLE + TABLE UNIT	MV-1100S/MV-1100D	
	0012	3560000F0	底座 BASE	1030\FC-25	1
	0020	3560001F0	鞍座 SADDLE	1040\FC-25	1
	0031	3560004E0	工作台 TABLE	1050\FC-25	1
	0040	3560458A0	地基墊塊 GROUND BLOCKS	3310\SS45C	11
	0050	3500085A0	地基調整螺絲 SCREW	3310\SS45C	11
	0060	3500086B0	螺帽 NUT	3310\SS45C (外徑41)	11
	0070	3560031C0	嵌條座 GIB BRACKET	1100\FC-25	2
	0080	3560032B0	嵌條 GIB	1180\FC-25	4
	0090	3560033B0	嵌條座 GIB BRACKET	1100\FC-25	2
	0100	3560034B0	嵌條座 GIB BRACKET	1100\FC-25	1
	0110	3560035B0	嵌條座 GIB BRACKET	1100\FC-25	1
	0120	3560036B0	嵌條 GIB	1180\FC-25	2
	0130	3560038B0	嵌條 GIB	1180\FC-25	1
	0140	3560064A0	斜楔調整板 ADJUSTABLE WEDGE PAD	3200\SS41	5
	0150	3560065A0	斜楔調整板 ADJUSTABLE WEDGE PAD	3200\SS41	4
	0160	3560076A0	嵌條壓板 PUSHING PAD, WEDGE	7120\SPCC	3
	0170	3560077B0	X軸嵌條壓板 PUSHING PAD, WEDGE	7120\SPCC	6
	0180	3560259A0	括屑片左前(X軸) LEFT SIDE REAR WIPER(X)	4380\NBR	2
	0190	3560260A0	括屑片左後(X軸) LEFT SIDE REAR WIPER(X)	4380\NBR	2
	0200	3560261A0	括屑片前右(Y軸) RIGHT SIDE FRONT WIPER(Y)	4380\NBR	2
	0210	3560262A0	括屑片前左(Y軸) LEFT SIDE FRONT WIPER(X)	4380\NBR	2
	0220	3560263A0	括屑片前右二(Y軸) RIGHT SIDE FRONT WIPER 2(Y)	4380\NBR	2
	0230	3560264A0	括屑片前左二(Y軸) LEFT SIDE FRONT WIPER 2(X)	4380\NBR	2
	0240	3560358A0	嵌條 GIB	1180\FC-25	2
	0250	3500081A0	碰塊 DOG	3140\SS41(42m/m)	4
	0260	3500082B0	碰塊座 DOG BRACKET	4140\AL(125m/m*3軌)	3
	0270	3500083A0	碰塊座 DOG BRACKET	4140\AL(90m/m*3軌)	1
	0280	3540007A0	碰塊 DOG	4140\AL 外購65L	2
	0290	3560050A0	支架 SUPPORTING BRACKET	3210\SS41	2
	0300	3560051A0	支架 SUPPORTING BRACKET	3210\SS41	2
	0310	3560052B0	Y軸前摺動罩 Y AXIS TELESCOPIC COVER UNIT	7400\SPCCZ	1
	0322	3560055E0	Y軸後摺動罩 Y AXIS TELESCOPIC COVER UNIT	7400\SPCCZ	1
	0330	3560056A0	支撐板 PLATE	3180\SS41	2
	0340	3560057A0	支架 SUPPORTING BRACKET	3180\SS41	2
	0350	3560058A0	支架 SUPPORTING BRACKET	3180\SS41	2

<續下頁>

台灣力得衛宇龍科技股份有限公司

*單階材料用量清單

製表日期: 97-06-13

第2頁

主件品號	序號	元件品號	品名 英文品名	規 格	用 量
2F13004	0360	3560059A0	Y軸微動開關座 MICRO SWITCH BRACKET, Y AXIS	3160\SS41	1
	0370	3560060A0	X軸微動開關座(一) MICRO SWITCH BRACKET, X AXIS	3160\SS41	1
	0381	3560061B0	X軸微動開關座(二) MICRO SWITCH BRACKET, X AXIS	3160\SS41	1
	0390	3560062A0	X軸碰塊座支架(右) RIGHT DOG BRACKET SUPPORTER(X)	3210\SS41	1
	0400	3560063A0	X軸碰塊座支架(左) LEFT DOG BRACKET SUPPORTER(X)	3210\SS41	1
	0410	3560066C0	Y軸下聯動管座 LOWER CONDUIT BRACKET (Y)	7180\SPCC	1
	0420	3560067B0	Y軸上聯動管座 UPPER CONDUIT BRACKET (Y)	7210\SPCC	1
	0450	3560295B0	X軸摺動罩組 X AXIS TELESCOPIC COVER UNIT	9400\SPCCZ	2
	0460	3560296A0	X軸摺動罩支架 TELESCOPIC COVER BRACKET	3210\SS41	4
	0470	3560079A0	底座側蓋板 SIDE COVER, BASE	7510\SPCC	2
	0480	3560080A0	工作台蓋板 TABLE COVER	7510\SPCC	2
	0500	3560082B0	工作台後蓋板 REAR COVER, TABLE	7510\SPCC	1
	0511	3560239B0	分油座固定板 OIL DISTRIBUTOR BRACKET	7210\SPCC	1
	0520	4640026038	方型聯動管 WIRE CONDUIT	CECBO01-26*38-142(18P)/R50	1
	0540	4800143204	微動開關 MICRO SWITCH	BNS819-B02-D12-61-12-10BALLUFF	2
	0553	3560423D0	底座後檔板 BASE REAR PLATE	7180\SPCC	1
	0561	3560424B0	Y軸後擋片 (Y) REAR PLATE	7210\SPCC	2
	0600	3560515A0	工作台前飾板 FRONT PLATE, TABLE	7510\SPCC	1
	0612	3560516D0	油管上固定座 UPPER PIPE BRACKET	7210\SPCC	1
	0621	3560517B0	油管下固定座 LOWER PIPE BRACKET	7210\SPCC	1
	0630	4180018100	耐油管 OIL PIPE		1
	0642	3560499C0	油冷機支架 OIL COOLER SUPPORTER	7210\SPCC	1

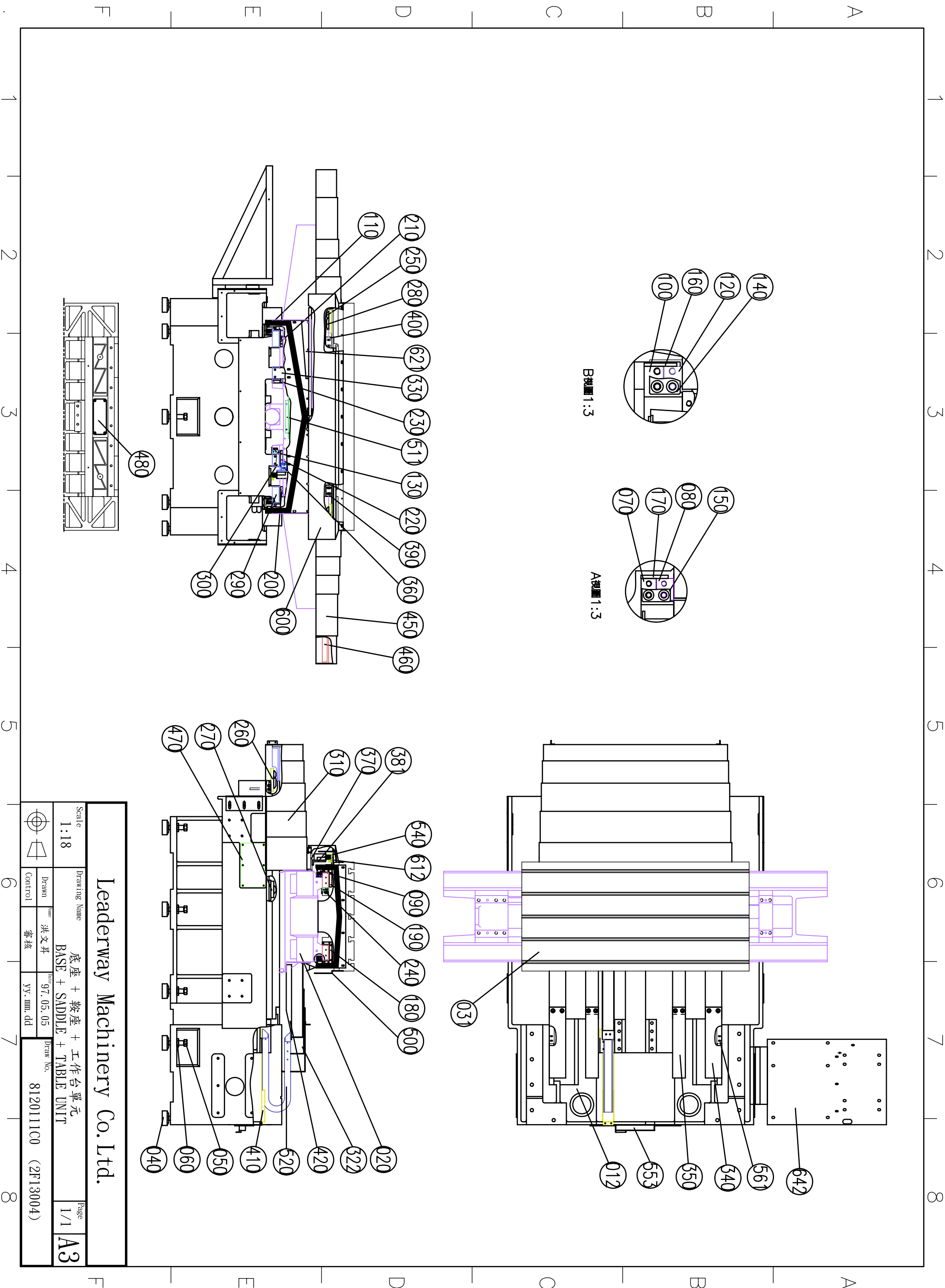

Leaderway Machinery Co. Ltd.

Scale		Drawing Name		Page	
1:18		底座 + 鞍座 + 工作台單元 BASE + SADDLE + TABLE UNIT		1/1	
Drawn	洪文昇	Date	97.05.05	Draw No.	8120111C0 (2F13004)
Control	審核		yy_mml_dd		

台灣力得衛宇龍科技股份有限公司

*單階材料用量清單

製表日期: 99-08-17

第1頁

主件品號	序號	元件品號	品名 英文品名	規 格	月量
2F13005			底座+鞍座+工作台單元 BASE + SADDLE + TABLE UNIT	MV-1300S/MV-1300D	
	0010	3560458A0	地基墊塊 GROUND BLOCKS	3230\S45C	11
	0020	3500081A0	碰塊 DOG	3140\SS41(42m/m)	4
	0030	3500082B0	碰塊座 DOG BRACKET	4140\AL(125m/m*3軌)	1
	0040	3500083A0	碰塊座 DOG BRACKET	4140\AL(90m/m*3軌)	1
	0050	3500085A0	地基調整螺絲 SCREW	3310\S45C	11
	0060	3500086B0	螺帽 NUT	3310\S45C (外徑41)	11
	0070	3540007A0	碰塊 DOG	4140\AL 外購65L	2
	0080	3560034B0	嵌條座 GIB BRACKET	1100\FC-25\3560034B2	1
	0090	3560035B0	嵌條座 GIB BRACKET	1100\FC-25\3560035B2	1
	0100	3560036B0	嵌條 GIB	1180\FC-25\取消B2、B3	2
	0112	3560055E0	Y軸後摺動罩 Y AXIS TELESCOPIC COVER UNIT	7400\SPCCZ	1
	0120	3560057A0	支架 SUPPORTING BRACKET	3180\SS41	2
	0130	3560059A0	Y軸微動開關座 MICRO SWITCH BRACKET, Y AXIS	3160\SS41	1
	0140	3560064A0	斜楔調整板 ADJUSTABLE WEDGE PAD	3200\SS41	9
	0151	3560066C0	Y軸下聯動管座 LOWER CONDUIT BRACKET (Y)	7180\SPCC	1
	0160	3560067B0	Y軸上聯動管座 UPPER CONDUIT BRACKET (Y)	7210\SPCC	1
	0170	3560076A0	嵌條壓板 PUSHING PAD, WEDGE	7120\SPCC	3
	0180	3560079A0	底座側蓋板 SIDE COVER, BASE	7510\SPCC	2
	0190	3560133A0	嵌條 GIB	1180\FC-25	1
	0200	3560259A0	括屑片左前(X軸) LEFT SIDE REAR WIPER(X)	4380\NBR	2
	0210	3560260A0	括屑片左後(X軸) LEFT SIDE REAR WIPER(X)	4380\NBR	2
	0220	3560261A0	括屑片前右(Y軸) RIGHT SIDE FRONT WIPER(Y)	4380\NBR	2
	0230	3560262A0	括屑片前左(Y軸) LEFT SIDE FRONT WIPER(X)	4380\NBR	2
	0240	3560263A0	括屑片前右二(Y軸) RIGHT SIDE FRONT WIPER 2(Y)	4380\NBR	2
	0250	3560264A0	括屑片前左二(Y軸) LEFT SIDE FRONT WIPER 2(X)	4380\NBR	2
	0262	3570001D0	工作台 TABLE	1050\FC-30\3570001A2	1
	0270	3570002A0	嵌條 GIB	1180\FC-25	2
	0281	3570003B0	嵌條座(右後左前) GIB BRACKET	1100\FC-25\3560031C2	2
	0291	3570004B0	嵌條座(左後右前) GIB BRACKET	1100\FC-25\3560033B2	2
	0301	3570005B0	嵌條 GIB	1180\FC-25	4

<續下頁>

台灣力得衛宇龍科技股份有限公司

*單階材料用量清單

製表日期: 99-08-17

第2頁

主作品號	序號	元作品號	品名 英文品名	規 格	月量
2F13005	0310	3570006B0	X軸右碰塊座支架 RIGHT DOG BRACKET SUPPORTER(7210\SPCC	1
	0320	3570007B0	X軸左碰塊座支架 LEFT DOG BRACKET SUPPORTER(X	7210\SPCC	1
	0330	3570121A0	X軸微動開關座(一) MICRO SWITCH BRACKET, X AXIS	7160\SPCC	1
	0340	3570122A0	X軸微動開關座(二) MICRO SWITCH BRACKET, X AXIS	7160\SPCC	1
	0351	3570009C0	工作台前飾板 FRONT PLATE, TABLE	7510\SPCC	1
	0360	3570010B0	工作台後蓋板 REAR COVER, TABLE	7510\SPCC	1
	0370	3570011C0	X軸摺動防屑罩 X AXIS TELESCOPIC COVER	7500\2t SPCCZ	2
	0381	3570016B0	側面嵌條檔片 STOPPING PAD, SIDE GIB	7180\SPCC	6
	0390	3570125A0	左前支架 LEFT SIDE FRONT BRACKET	3210\SS41	2
	0400	3570123A0	左前延伸座 SADDLE EXTENSION BRACKET(L)	1180\3570123A2\FC-30	2
	0410	3570126A0	右前支架 RIGHT SIDE FRONT BRACKET	3210\SS41	2
	0420	3570124A0	右前延伸座 SADDLE EXTENSION BRACKET(R)	1180\FC-30\3570124A2	2
	0431	3570042B0	Y軸前摺動罩 Y AXIS TELESCOPIC COVER UNIT	7400\SPCCZ	1
	0440	3570043B0	Y軸摺動罩支架 TELESCOPIC COVER BRACKET	3210\SS41	2
	0454	3570047F0	底座 BASE	1030\FC-25\3560000C2	1
	0460	3570048C0	鞍座 SADDLE	1040\FC-25\3560001B2	1
	0470	3580048A0	碰塊座 DOG BRACKET	4140\AL(200m/m*2軌)	2
	0481	4640026038	方型聯動管 WIRE CONDUIT	CECBO01-26*38-142(18P)/R50	1
	0490	4800143204	微動開關 MICRO SWITCH	BNS819-B02-D12-61-12-10BALLU	2
	0570	3560058A0	支架 SUPPORTING BRACKET	3180\SS41	2
	0584	3560423E0	底座後檔板 BASE REAR PLATE	7180\SPCC	1
	0591	3560424B0	Y軸後擋片 (Y) REAR PLATE	7210\SPCC	2
	0611	3570128B0	上油管座 UPPER OIL PIPE BRACKET	7210\SPCC	1
	0620	3560517B0	油管下固定座 LOWER PIPE BRACKET	7210\SPCC	1
	0630	4180018115	直型高壓油管 HIGH-PRESSURE HOSE	1/8"R1x1150L	1
	0641	3560499C0	油冷機支架 OIL COOLER SUPPORTER	7210\SPCC	1

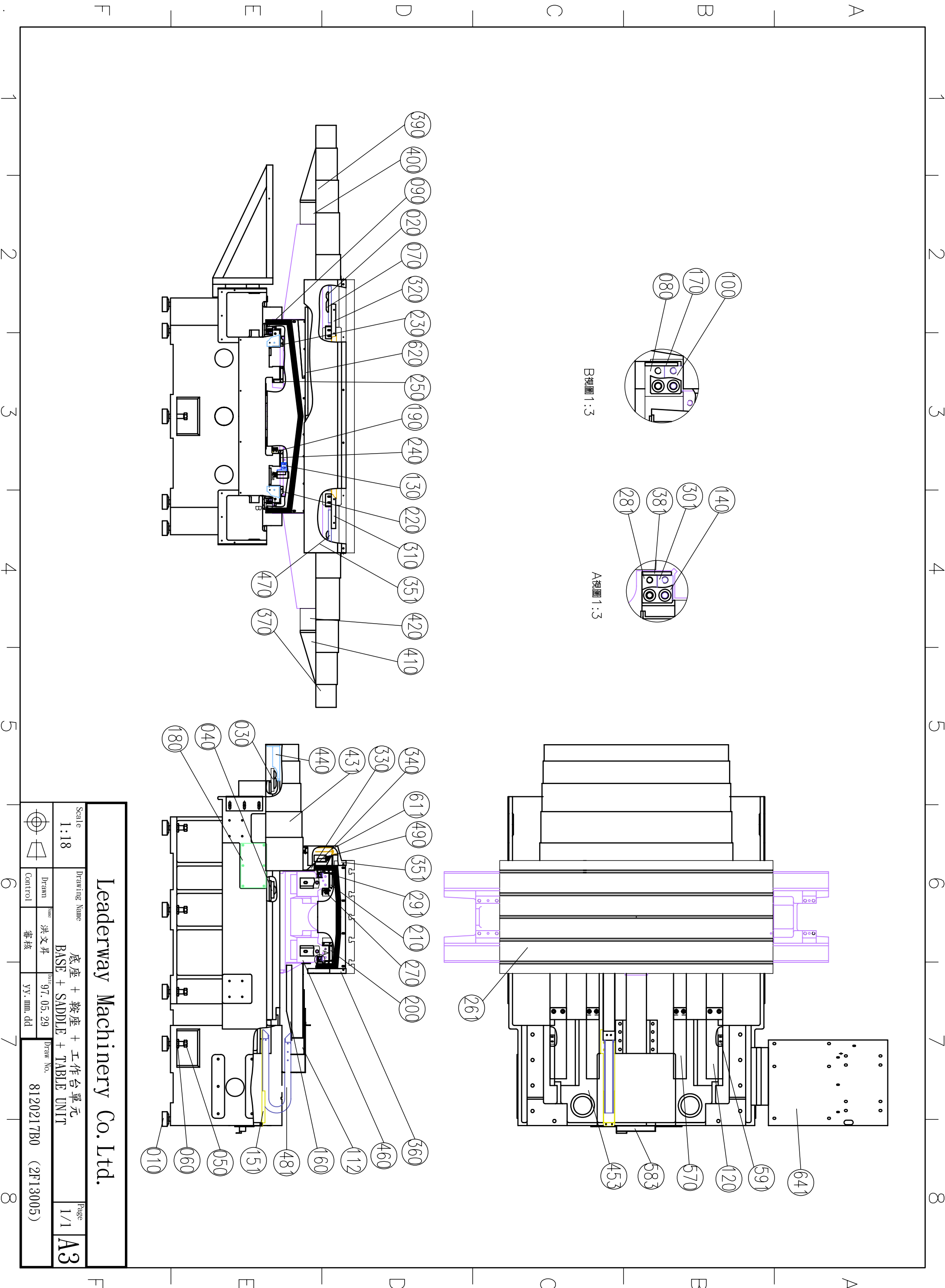

Leaderway Machinery Co. Ltd.

Scale		Drawing Name		Page	
1:18		底座 + 鞍座 + 工作台單元 BASE + SADDLE + TABLE UNIT		1/1	
Drawn	Name	Date	Draw No.	A3	
Control	洪文昇	97.05.29	8120217B0 (2F13005)		
	審核	yy-mm-dd			

台灣力得衛宇龍科技股份有限公司

*單階材料用量清單

製表日期: 99-08-17

第1頁

主件品號	序號	元件品號	品名 英文品名	規 格	月量
2F16001			配重單元 COUNTER BALANCE UNIT	V1100/MV1100S/MV1300S	
	0010	3560010A0	鏈條滾輪 ROLLER	3260\S45C	4
	0020	3560011A0	配重隔環 COUNTER BALANCE SPACER	3230\S45C	8
	0031	3560029B0	鏈輪軸 SHAFT SPROCKET	3260\S45C	4
	0040	3560048B0	配重螺絲固定座 FIXED SEAT	3310\S45C	2
	0050	3560229A0	鏈條連結螺絲 CHAIN CONNECTING BOLT	4310\SNM8 #80	4
	0060	3560483A0	配重 COUNTER BALANCE	3070\SS41\3560483A2	1
	0071	3570027C0	滑軌上固定板 UPPER FIXED PLATE, GUIDING R	3180\SS41	1
	0080	3570028B0	配重導桿 GUIDING ROD, COUNTER BALANCE	4290\圓棒	1
	0091	3570029B0	滑軌下固定板 LOWER FIXED PLATE, GUIDING R	3180\SS41	1
	0100	4060600062	C型扣環(孔用) C TYPE RETAINER RING	R-62	4
	0120	4400206206	深槽滾珠軸承 BEARING	6206ZZ 30*62*16	8
	0130	4610080061	鏈條 CHAIN	80x61P(1549.4mm)(附半目2只)	2
	0140	3570025A0	配重滑塊 SLIDING BLOCK, COUNTER BALANC	4370\MC	4
	0150	3570026A0	滑塊固定板 FIXED BRACKET, SLIDING BLOCK	3180\SS41	4
	0161	3560030D0	鏈輪軸固定座 SPROCKET SHAFT BRACKET	1210\FC-25\3560030B2	2

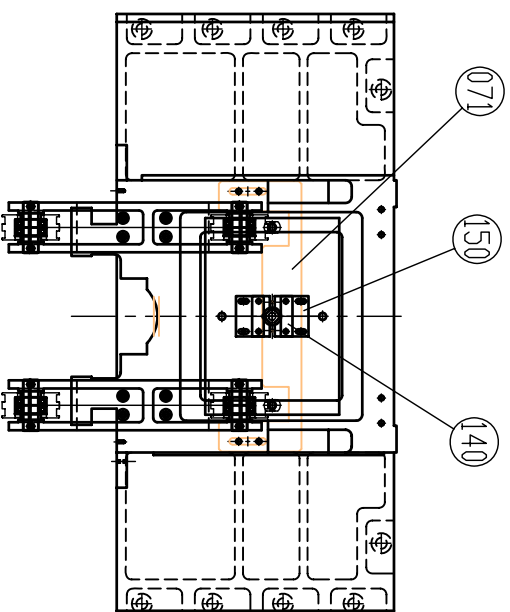
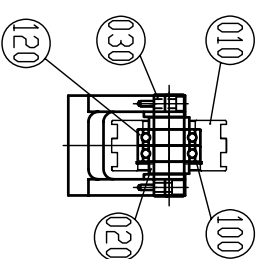
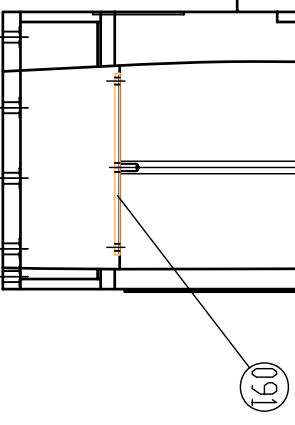
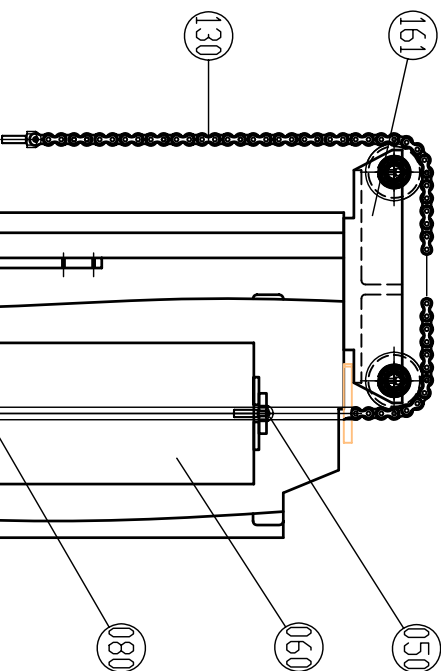
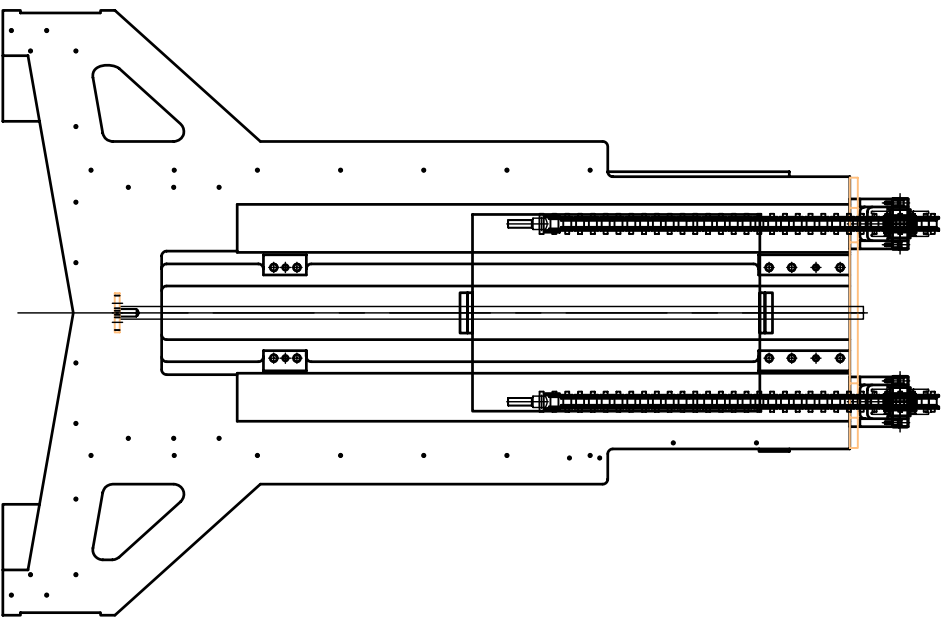

V-1100\MV-1100S\MV-1300S

Leaderway Machinery Co. Ltd.

Scale
1:12

Drawing Name

配重單元
COLUMN UNIT

Page

1/1
A4

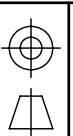

Drawn

Control

徐維駿
審核

Date
97.05.16
yy.mm.dd

Draw No.

8120110B0(2F16001)

台灣力得衛宇龍科技股份有限公司

*單階材料用量清單

製表日期: 99-08-17

第1頁

主件品號	序號	元件品號	品名 英文品名	規 格	月量
2F16003			配重單元 COUNTER BALANCE UNIT	MV1100D/MV1300D	
	0010	3560010A0	鏈條滾輪 ROLLER	3260\S45C	4
	0020	3560011A0	配重隔環 COUNTER BALANCE SPACER	3230\S45C	8
	0031	3560029B0	鏈輪軸 SHAFT SPROCKET	3260\S45C	4
	0040	3560229A0	鏈條連結螺絲 CHAIN CONNECTING BOLT	4310\SNCM8 #80	4
	0052	3560030D0	鏈輪軸固定座 SPROCKET SHAFT BRACKET	1210\FC-25\3560030B2	2
	0061	3570027C0	滑軌上固定板 UPPER FIXED PLATE, GUIDING R	3180\SS41	1
	0070	3570028B0	配重導桿 GUIDING ROD, COUNTER BALANCE	4290\圓棒	1
	0081	3570029B0	滑軌下固定板 LOWER FIXED PLATE, GUIDING R	3180\SS41	1
	0090	3570103A0	配重 COUNTER BALANCE	3070\3570103A2\SS41	1
	0100	4060600062	C型扣環(孔用) C TYPE RETAINER RING	R-62	4
	0110	4400206206	深槽滾珠軸承 BEARING	6206ZZ 30*62*16	8
	0121	4610080053	鏈條 CHAIN	80x53P(1346.2mm)(附全目2只)	2
	0130	3570025A0	配重滑塊 SLIDING BLOCK,COUNTER BALANC	4370\MC	4
	0140	3570026A0	滑塊固定板 FIXED BRACKET, SLIDING BLOCK	3180\SS41	4

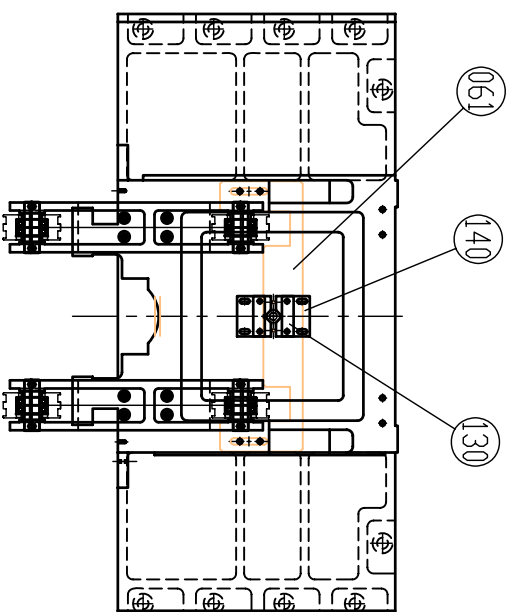
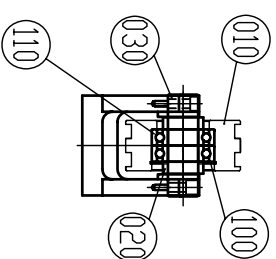
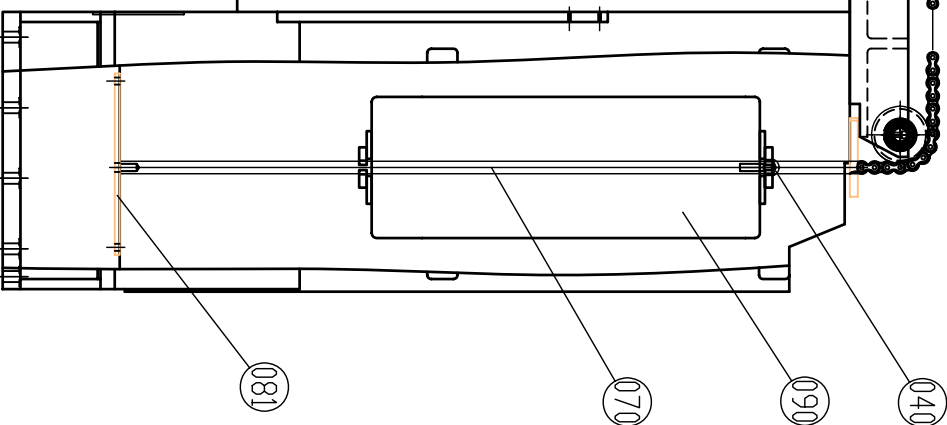
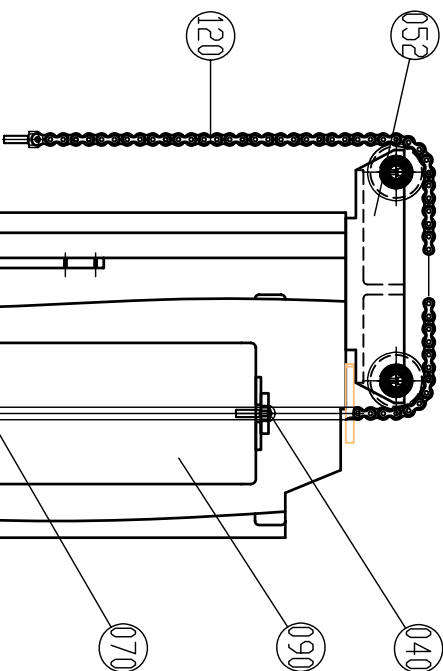
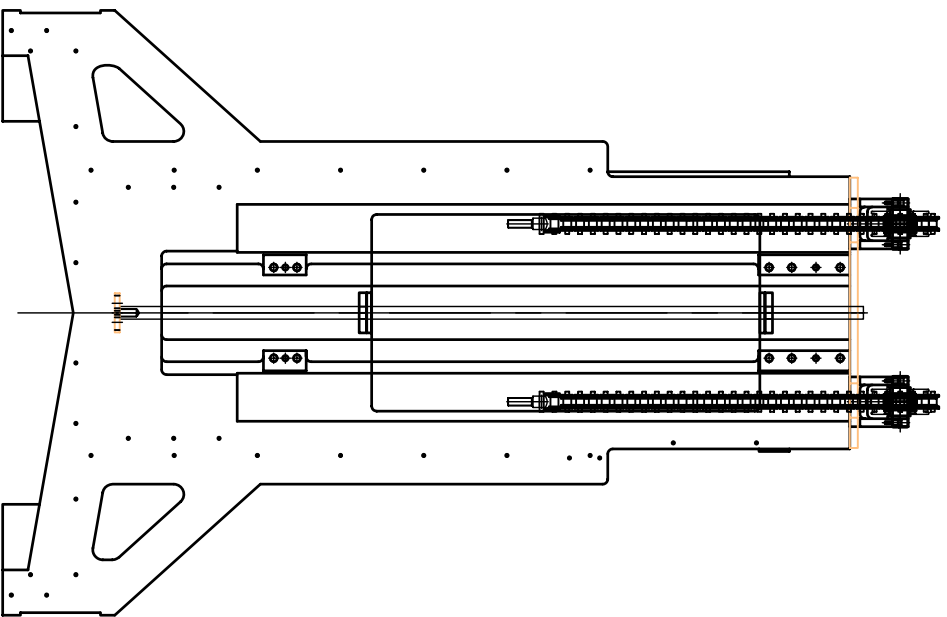

MV-1100D\MV-1300D

Leaderway Machinery Co. Ltd.

Scale
1:12

Drawing Name

配重單元
COLUMN UNIT

Page

1/1
A4

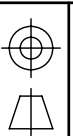

Drawn

Control

徐維駿
審核

Date
97.05.16
yy.mm.dd

Draw No.

8120153B0(2F16003)

台灣力得衛宇龍科技股份有限公司

*單階材料用量清單

製表日期: 97-06-13

第1頁

主件品號	序號	元件品號	品名 英文品名	規 格	量
2F21003			X軸傳動單元 X AXIS TRANSMISSION UNIT	MV-1100S	
	0011	3170053B0	軸承隔環 BEARING SPACER	3230\SCM4	1
	0021	3170054B0	前迷宮環座 LAMINAL RING BRACKET	3250\SCM4	2
	0031	3170057B0	軸承隔環 BEARING SPACER	3230\SCM4	1
	0040	3170067A0	預拉彈簧檔片 PRELOAD SPRING STOPPER	3230\S45C	1
	0050	3170070A0	Z軸尾端軸承座 REAR BEARING HOUSING	1080\S45C	1
	0060	3170074C0	Z軸軸承座防撞膠塊 RUBBER CUSHION	4370\PU	1
	0070	3560015C0	傳動座 TRANSMISSION HOUSING	1080\FC-25	1
	0081	3560016B0	軸承壓蓋 BEARING CAP	3240\SCM4	1
	0090	3560017B0	防撞膠塊 RUBBER CUSHION	4370\PU	1
	0102	3560018F0	防撞膠塊固定座 RUBBER CUSHION BRACKET	3240\SCM4	1
	0110	3560019B0	防撞膠固定座 RUBBER CUSHION BRACKET	3230\S45C	1
	0121	3560023E0	Z軸尾端軸承座壓板 PUSHING PLATE, Z AXIS BEARING HOUSING	3120\SCM4	1
	0131	3560024B0	軸承隔環 BEARING SPACER	3230\SCM4	1
	0140	3560132B0	尾端座蓋板 REAR BEARING HOUSING COVER	3180\SPCC	1
	0150	3984009A0	滾珠螺桿 X AXIS BALL SCREW	9860\40x1614LxP10	1
	0160	4020401030	鎖緊螺帽 LOCK UNT	MK30	1
	0170	4020402035	鎖緊螺帽 LOCK UNT	MR35(M35xP1.5)	1
	0180	4020403035	鎖緊螺帽 LOCK UNT	MF35(M35xP1.5)	1
	0190	4050175012	壓縮彈簧 COMPRESSIVE SPRING	φ 1.25X φ 7.5X12L	8
	0200	4061306828	迷宮環 LAMINAL RING	FK3-AS 62/2.8/0.82	6
	0210	4402030062	螺桿軸承 BALL SCREW BEARING	BS30M62/15-P4A.DUM	1
	0220	4402435072	螺桿軸承 BALL SCREW BEARING	BS35/72/15TUM	1
	0230	3560026C0	螺帽座 BALLSCREW HOUSING	1080\FC-25	1
	0240	3560027B0	尾端座 REAR BEARING HOUSING	1080\FC-25	1
	0250	3560111B0	傳動座蓋板 TRANSMISSION HOUSING COVER	7180\SPCC	1

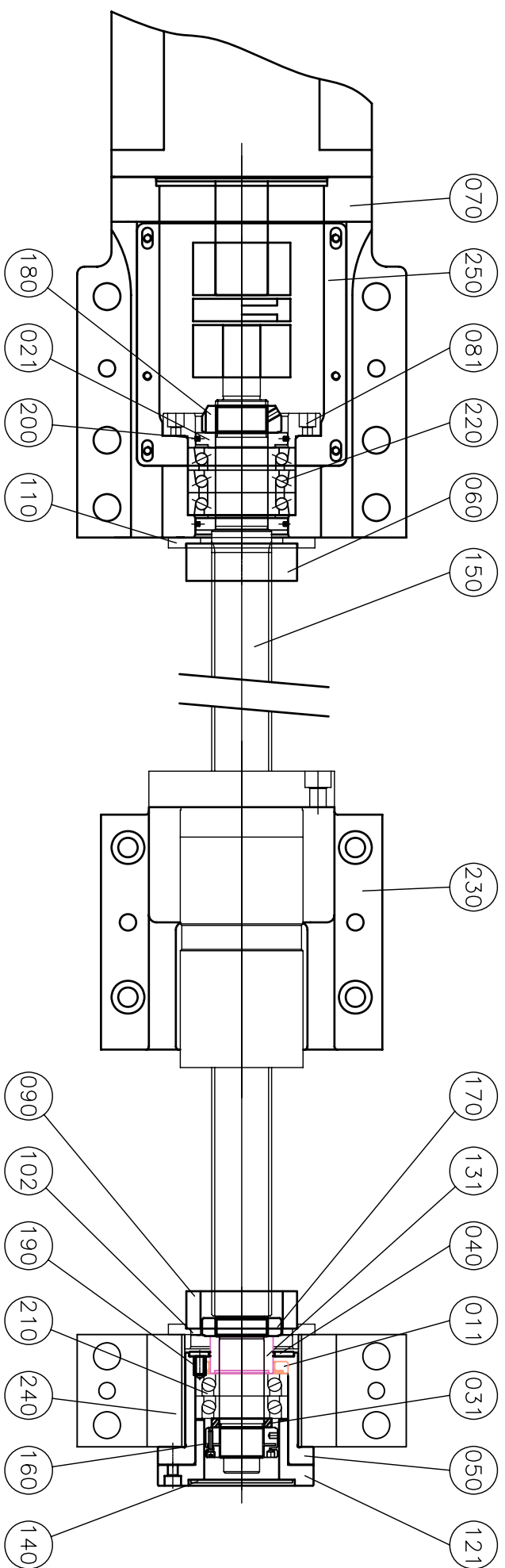

MV-1100S/MV-1100D

Leaderway Machinery Co. Ltd.

Scale		Drawing Name		Page	
1:4		X-AXIS TRANSMISSION UNIT(X軸傳動單元)		1/1	
Drawn		Name		Draw No.	
Control		徐維駿		8120143B0(2F21003)	
		審核		Date	
				97.05.30	
				yy. mm. dd	

A4

台灣力得衛宇龍科技股份有限公司

*單階材料用量清單

製表日期: 99-08-17

第1頁

主件品號	序號	元件品號	品名 英文品名	規 格	月量
2F21004			X軸傳動單元 X AXIS TRANSMISSION UNIT	MV-1300S/MV-1300D	
	0010	3170044C0	壓縮彈簧座 COMPRESSIVE SPRING BRACKET	3240\S45C	1
	0021	3170054B0	前迷宮環座 LAMINAL RING BRACKET	3250\SCM4	3
	0030	3560015C0	傳動座 TRANSMISSION HOUSING	1080\3560015A2\FC-25	1
	0041	3560016B0	軸承壓蓋 BEARING CAP	3240\SCM4	1
	0050	3560019B0	防撞膠固定座 RUBBER CUSHION BRACKET	3230\S45C	1
	0060	3560111B0	傳動座蓋板 TRANSMISSION HOUSING COVER	7180\SPCC	1
	0071	3570032B0	螺帽座 BALLSCREW HOUSING	1080\FC-25\3560026C2	1
	0080	3570033B0	尾端座 REAR BEARING HOUSING	1080\FC-25\3560027A2	1
	0091	3570034B0	軸承壓蓋 BEARING CAP	3240\SCM4	1
	0101	3570035B0	隔環 SPACER	3230\SCM4	1
	0111	3570036C0	彈簧壓蓋 SPRING CAP	3240\S45C	1
	0121	3570037C0	防水隔環 SPACER	3230\SCM4	1
	0130	3570038B0	軸承座 BEARING HOUSING	3250\S45C	1
	0140	3570040B0	防撞膠墊 RUBBER CUSHION	4370\PU	2
	0150	3984018A0	滾珠螺桿 BALL SCREW	9860	1
	0160	4020403035	鎖緊螺帽 LOCK NUT	MF35(M35xP1.5)	1
	0170	4020403040	鎖緊螺帽 LOCK NUT	MF40	1
	0180	4020405035	鎖緊螺帽(軸向) AXIAL LOCK NUT	MKR-35 X1.5P	1
	0190	4050110032	壓縮彈簧 COMPRESSIVE SPRING	扁圓形 ϕ 10x32-1.8x1.1	6
	0200	4061306828	迷宮環 LAMINAL RING	FK3-AS 62/2.8/0.82	12
	0210	4402035072	螺桿軸承 BALL SCREW BEARING		1
	0220	4402435072	螺桿軸承 BALL SCREW BEARING	BS35/72/15TUM	1

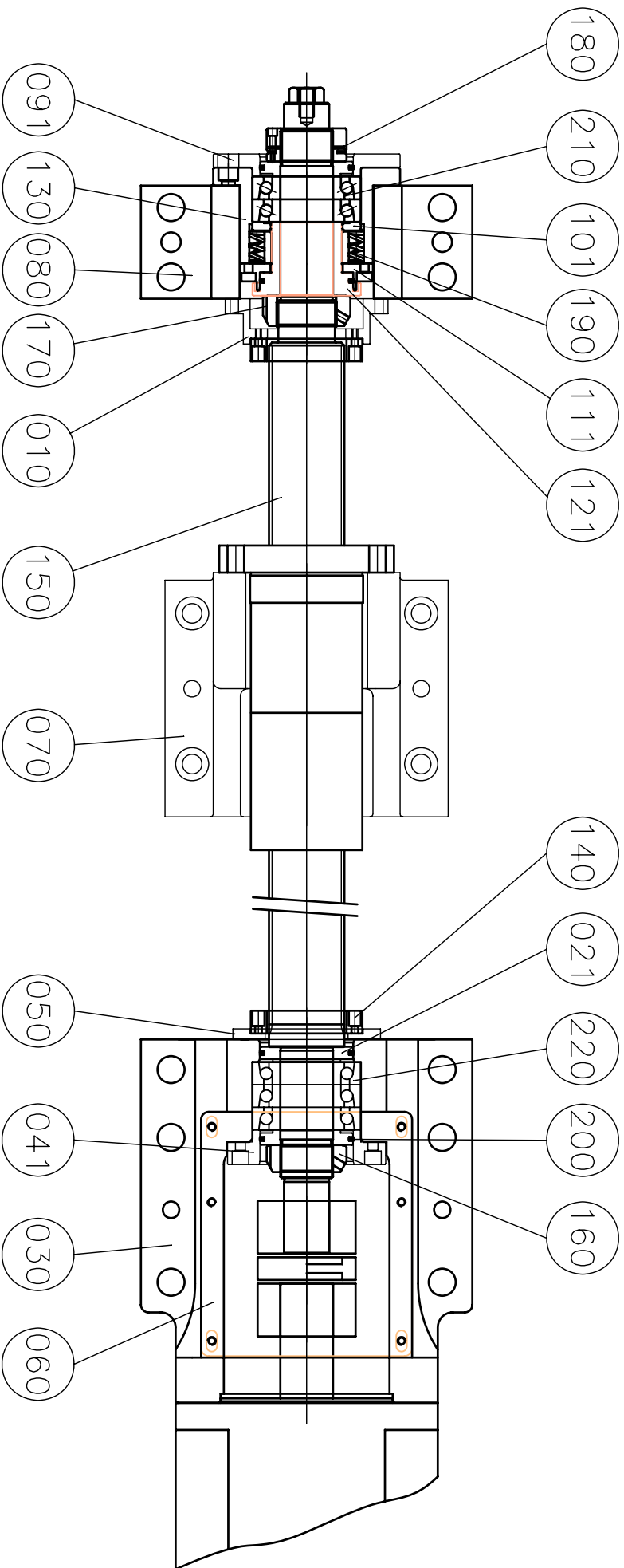

MV-1300S/MV-1300D

Leaderway Machinery Co. Ltd.

Scale 1:4		Drawing Name X-AXIS TRANSMISSION UNIT(X軸傳動單元)		Page 1/1
Drawn Control	Name 徐維駿 審核	Date 97.06.04 yy.mm.dd	Draw No. 8120142B0(2F21004)	A4

台灣力得衛宇龍科技股份有限公司

*單階材料用量清單

製表日期: 97-06-13

第1頁

主件品號	序號	元件品號	品名 英文品名	規 格	量
2F21015			X軸傳動單元 X AXIS TRANSMISSION UNIT	MV1100S/FAGOR/H.D.H	
	0010	3170053B0	軸承隔環 BEARING SPACER	3230\SCM4	1
	0020	3170054B0	前迷宮環座 LAMINAL RING BRACKET	3250\SCM4	2
	0030	3170057B0	軸承隔環 BEARING SPACER	3230\SCM4	1
	0040	3170067A0	預拉彈簧檔片 PRELOAD SPRING STOPPER	3230\S45C	1
	0050	3170070A0	Z軸尾端軸承座 REAR BEARING HOUSING	1080\S45C	1
	0060	3170074C0	Z軸軸承座防撞膠塊 RUBBER CUSHION	4370\PU	1
	0070	3560098B0	傳動座(共用3560015A0木型) TRANSMISSION HOUSING	1080\FC-25	1
	0080	3560016B0	軸承壓蓋 BEARING CAP	3240\SCM4	1
	0090	3560017B0	防撞膠塊 RUBBER CUSHION	4370\PU	1
	0100	3560018F0	防撞膠塊固定座 RUBBER CUSHION BRACKET	3240\SCM4	1
	0110	3560019B0	防撞膠固定座 RUBBER CUSHION BRACKET	3230\S45C	1
	0120	3560023E0	Z軸尾端軸承座壓板 PUSHING PLATE, Z AXIS BEARING	3120\SCM4	1
	0130	3560024B0	軸承隔環 BEARING SPACER	3230\SCM4	1
	0140	3560132B0	尾端座蓋板 REAR BEARING HOUSING COVER	3180\SPCC	1
	0150	3984009A0	滾珠螺桿 X AXIS BALL SCREW	9860\40x1614LxP10	1
	0160	4020401030	鎖緊螺帽 LOCK UNT	MK30	1
	0170	4020402035	鎖緊螺帽 LOCK UNT	MR35(M35xP1.5)	1
	0180	4020403035	鎖緊螺帽 LOCK UNT	MF35(M35xP1.5)	1
	0190	4050175012	壓縮彈簧 COMPRESSIVE SPRING	φ 1.25X φ 7.5X12L	8
	0200	4061306828	迷宮環 LAMINAL RING	FK3-AS 62/2.8/0.82	6
	0210	4402030062	螺桿軸承 BALL SCREW BEARING	BS30M62/15-P4A.DUM	1
	0220	4402435072	螺桿軸承 BALL SCREW BEARING	BS35/72/15TUM	1
	0230	3560026C0	螺帽座 BALLSCREW HOUSING	1080\FC-25	1
	0240	3560027B0	尾端座 REAR BEARING HOUSING	1080\FC-25	1
	0250	3560111B0	傳動座蓋板 TRANSMISSION HOUSING COVER	7180\SPCC	1

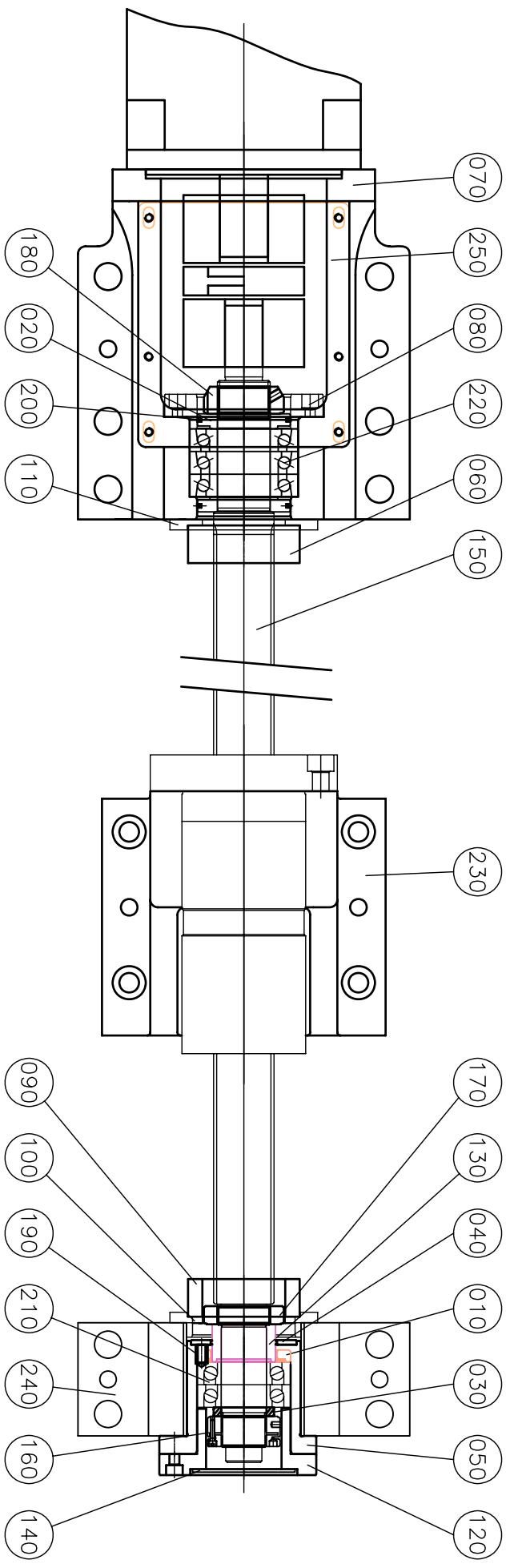

MV-1100S/MV-1100D(HDH, FAGOR)

Leaderway Machinery Co. Ltd.

Scale		Drawing Name		Page	
1:4		X-AXIS TRANSMISSION UNIT(X軸傳動單元)		1/1	
Drawn		Name		Draw No.	
Control		徐維駿		812009500(2F21015)	
		審核			
		Date			
		97.06.04			
		y.y. mm. dd			

A4

台灣力得衛宇龍科技股份有限公司

*單階材料用量清單

製表日期: 99-08-17

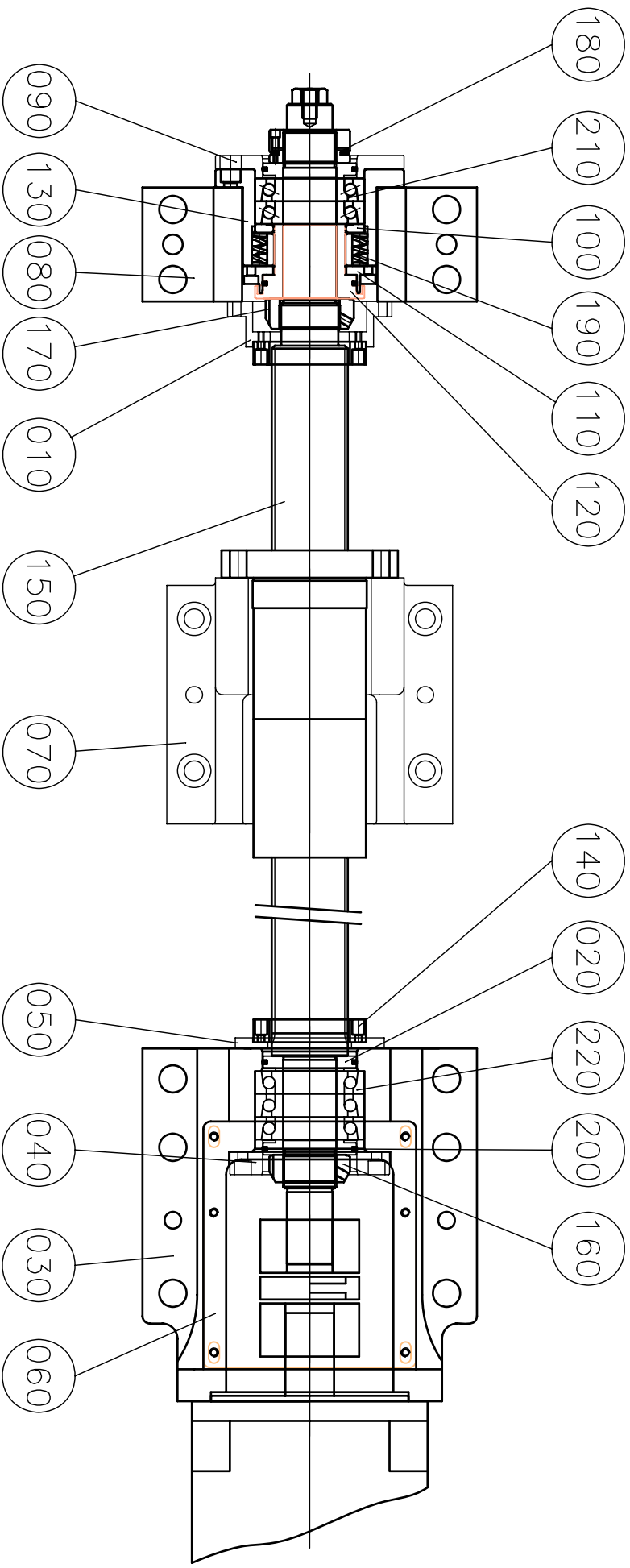

第1頁

主件品號	序號	元件品號	品名 英文品名	規 格	數量
2F21016			X軸傳動單元 X AXIS TRANSMISSION UNIT	MV-1300S/MV-1300D(H.D.H)	
	0010	3170044C0	壓縮彈簧座 COMPRESSIVE SPRING BRACKET	3240\S45C	1
	0020	3170054B0	前迷宮環座 LAMINAL RING BRACKET	3250\SCM4	3
	0030	3560098B0	傳動座 TRANSMISSION HOUSING	1080\FC-25\3560015A2	1
	0040	3560016B0	軸承壓蓋 BEARING CAP	3240\SCM4	1
	0050	3560019B0	防撞膠固定座 RUBBER CUSHION BRACKET	3230\S45C	1
	0060	3560111B0	傳動座蓋板 TRANSMISSION HOUSING COVER	7180\SPCC	1
	0071	3570032B0	螺帽座 BALLSCREW HOUSING	1080\FC-25\3560026C2	1
	0080	3570033B0	尾端座 REAR BEARING HOUSING	1080\FC-25\3560027A2	1
	0090	3570034B0	軸承壓蓋 BEARING CAP	3240\SCM4	1
	0100	3570035B0	隔環 SPACER	3230\SCM4	1
	0110	3570036C0	彈簧壓蓋 SPRING CAP	3240\S45C	1
	0120	3570037C0	防水隔環 SPACER	3230\SCM4	1
	0130	3570038B0	軸承座 BEARING HOUSING	3250\S45C	1
	0140	3570040B0	防撞膠墊 RUBBER CUSHION	4370\PU	2
	0150	3984018A0	滾珠螺桿 BALL SCREW	9860	1
	0160	4020403035	鎖緊螺帽 LOCK NUT	MF35(M35xP1.5)	1
	0170	4020403040	鎖緊螺帽 LOCK NUT	MF40	1
	0180	4020405035	鎖緊螺帽(軸向) AXIAL LOCK NUT	MKR-35 X1.5P	1
	0190	4050110032	壓縮彈簧 COMPRESSIVE SPRING	扁圓形 ϕ 10x32-1.8x1.1	6
	0200	4061306828	迷宮環 LAMINAL RING	FK3-AS 62/2.8/0.82	12
	0210	4402035072	螺桿軸承 BALL SCREW BEARING		1
	0220	4402435072	螺桿軸承 BALL SCREW BEARING	BS35/72/15TUM	1



MV-1300S/MV-1300D(HDH)

Leaderway Machinery Co. Ltd.

Scale 1:4		Drawing Name X-AXIS TRANSMISSION UNIT(X軸傳動單元)		Page 1/1	
Drawn Control		Name 徐維駿 審核		Date 97.06.04 y.y. mm. dd	
		Draw No. 8120223B0(2F21016)			
				A4	

台灣力得衛宇龍科技股份有限公司

*單階材料用量清單

製表日期: 97-06-13

第1頁

主件品號	序號	元件品號	品名 英文品名	規 格	數量
2F22003			Y軸傳動單元 Y AXIS TRANSMISSION UNIT	MV-1100S	
	0011	3170053B0	軸承隔環 BEARING SPACER	3230\SCM4	1
	0021	3170054B0	前迷宮環座 LAMINAL RING BRACKET	3250\SCM4	2
	0031	3170057B0	軸承隔環 BEARING SPACER	3230\SCM4	1
	0040	3170067A0	預拉彈簧檔片 PRELOAD SPRING STOPPER	3230\S45C	1
	0050	3170070A0	Z軸尾端軸承座 REAR BEARING HOUSING	1080\S45C	1
	0060	3560015C0	傳動座 TRANSMISSION HOUSING	1080\FC-25	1
	0071	3560016B0	軸承壓蓋 BEARING CAP	3240\SCM4	1
	0080	3560017B0	防撞膠塊 RUBBER CUSHION	4370\PU	1
	0092	3560018F0	防撞膠塊固定座 RUBBER CUSHION BRACKET	3240\SCM4	1
	0100	3560019B0	防撞膠固定座 RUBBER CUSHION BRACKET	3230\S45C	1
	0111	3560023E0	Z軸尾端軸承座壓板 PUSHING PLATE, Z AXIS BEARING	3120\SCM4	1
	0121	3560024B0	軸承隔環 BEARING SPACER	3230\SCM4	1
	0130	3560132B0	尾端座蓋板 REAR BEARING HOUSING COVER	3180\SPCC	1
	0140	3560346A0	防撞膠塊 RUBBER CUSHION	4370\PU	1
	0150	3984010A0	滾珠螺桿 Y AXIS BALL SCREW	9860\40x1157LxP10	1
	0160	4020401030	鎖緊螺帽 LOCK UNT	MK30	1
	0170	4020402035	鎖緊螺帽 LOCK UNT	MR35(M35xP1.5)	1
	0180	4020403035	鎖緊螺帽 LOCK UNT	MF35(M35xP1.5)	1
	0190	4050175012	壓縮彈簧 COMPRESSIVE SPRING	φ 1.25X φ 7.5X12L	8
	0200	4061306828	迷宮環 LAMINAL RING	FK3-AS 62/2.8/0.82	6
	0210	4402030062	螺桿軸承 BALL SCREW BEARING	BS30M62/15-P4A.DUM	1
	0220	4402435072	螺桿軸承 BALL SCREW BEARING	BS35/72/15TUM	1
	0230	3560027B0	尾端座 REAR BEARING HOUSING	1080\FC-25	1
	0240	3560111B0	傳動座蓋板 TRANSMISSION HOUSING COVER	7180\SPCC	1

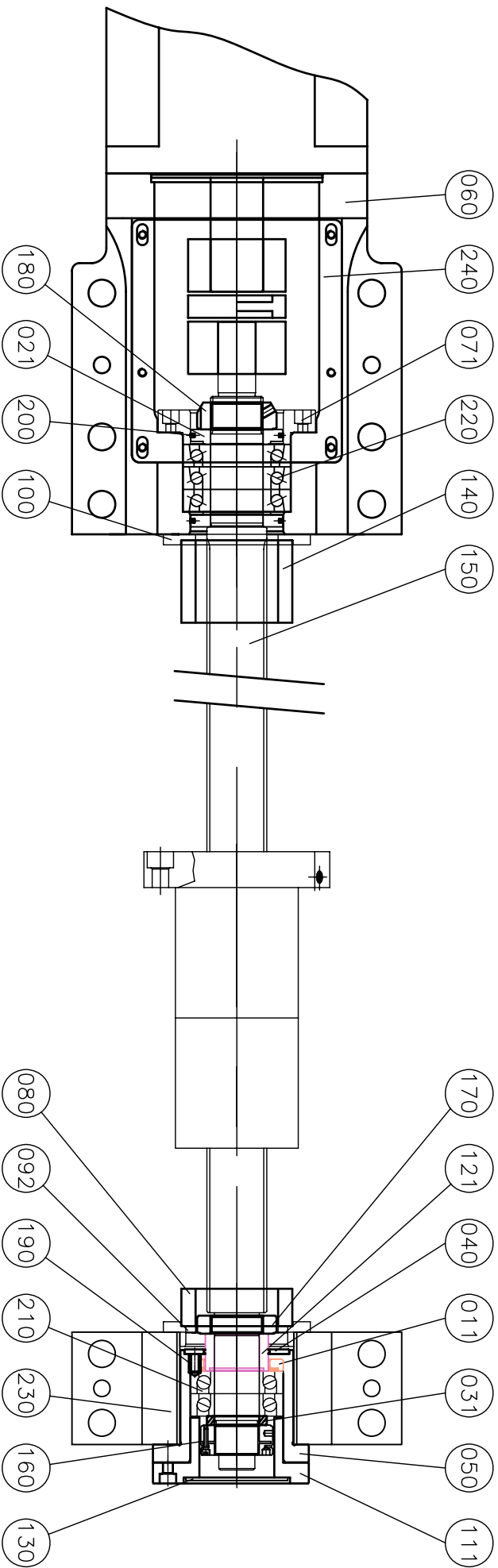

MV-1100S/MV-1100D

Leaderway Machinery Co. Ltd.

Scale 1:4		Drawing Name Y-AXIS TRANSMISSION UNIT(Y軸傳動單元)		Page 1/1	
Drawn Control		Name 徐維駿 審核		Date 97.05.30 yy.mm.dd	
		Draw No. 8120144B0(2F22003)			

台灣力得衛宇龍科技股份有限公司

*單階材料用量清單

製表日期: 99-08-17

第1頁

主件品號	序號	元件品號	品名 英文品名	規 格	月量
2F22004			Y軸傳動單元 Y AXIS TRANSMISSION UNIT	MV-1300S/MV-1300D	
	0010	3170044C0	壓縮彈簧座 COMPRESSIVE SPRING BRACKET	3240\S45C	1
	0021	3170054B0	前迷宮環座 LAMINAL RING BRACKET	3250\SCM4	3
	0030	3560017B0	防撞膠塊 RUBBER CUSHION	4370\PU	1
	0040	3560015C0	傳動座 TRANSMISSION HOUSING	1080\3560015A2\FC-25	1
	0051	3560016B0	軸承壓蓋 BEARING CAP	3240\SCM4	1
	0060	3560019B0	防撞膠固定座 RUBBER CUSHION BRACKET	3230\S45C	1
	0070	3560111B0	傳動座蓋板 TRANSMISSION HOUSING COVER	7180\SPCC	1
	0080	3570033B0	尾端座 REAR BEARING HOUSING	1080\FC-25\3560027A2	1
	0091	3570034B0	軸承壓蓋 BEARING CAP	3240\SCM4	1
	0101	3570035B0	隔環 SPACER	3230\SCM4	1
	0111	3570036C0	彈簧壓蓋 SPRING CAP	3240\S45C	1
	0121	3570037C0	防水隔環 SPACER	3230\SCM4	1
	0130	3570038B0	軸承座 BEARING HOUSING	3250\S45C	1
	0140	3570039A0	防撞膠固定座 RUBBER CUSHION BRACKET	3230\S45C	1
	0150	3570041A0	防撞膠墊 RUBBER CUSHION	4370\PU	1
	0160	3984019A0	滾珠螺桿 BALL SCREW	9860\φ 50xP10	1
	0170	4020403035	鎖緊螺帽 LOCK NUT	MF35(M35xP1.5)	1
	0180	4020403040	鎖緊螺帽 LOCK NUT	MF40	1
	0190	4020405035	鎖緊螺帽(軸向) AXIAL LOCK NUT	MKR-35 X1.5P	1
	0200	4050110032	壓縮彈簧 COMPRESSIVE SPRING	扁圓形 φ 10x32-1.8x1.1	6
	0210	4061306828	迷宮環 LAMINAL RING	FK3-AS 62/2.8/0.82	12
	0220	4402035072	螺桿軸承 BALL SCREW BEARING		1
	0230	4402435072	螺桿軸承 BALL SCREW BEARING	BS35/72/15TUM	1

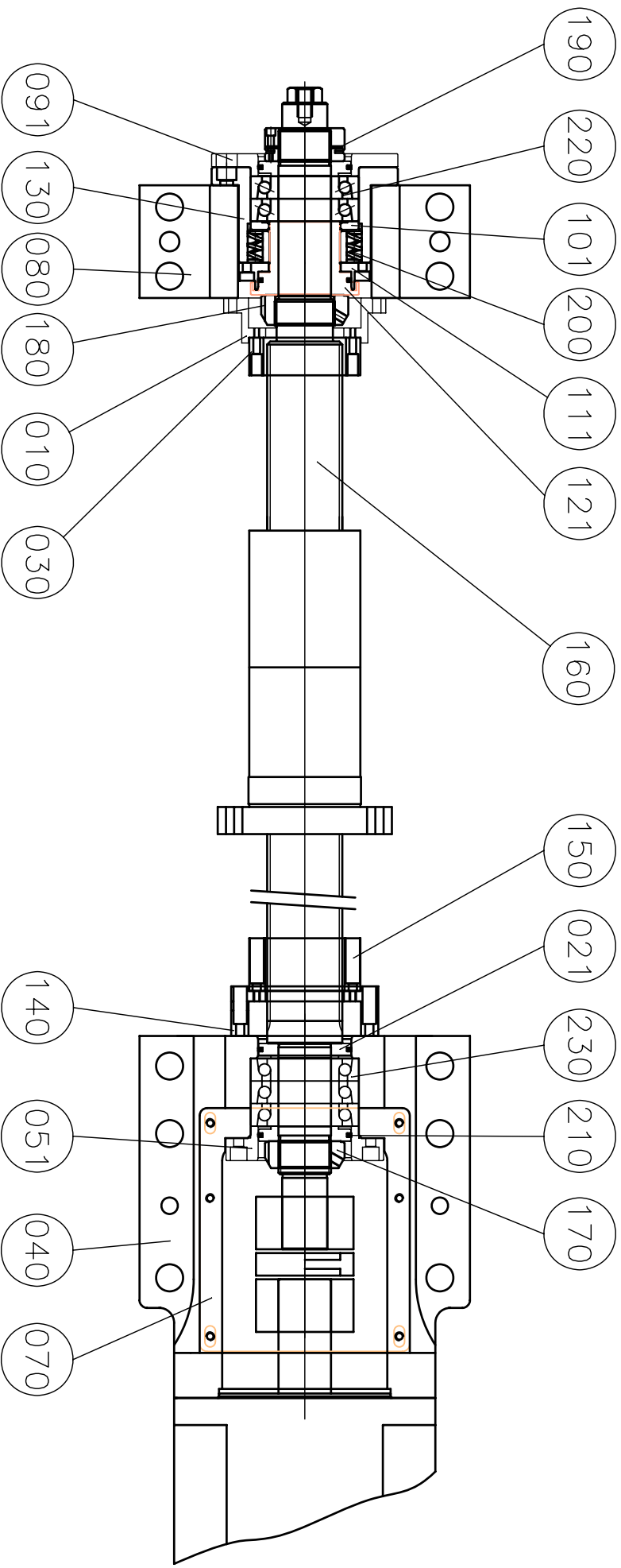

MV-1300S/MV-1300D

Leaderway Machinery Co. Ltd.

Scale 1:4		Drawing Name Y-AXIS TRANSMISSION UNIT(Y軸傳動單元)		Page 1/1
Drawn Control	Name 徐維駿 審核	Date 97.06.04 yy.mm.dd	Draw No. 8120141B0(2F22004)	A4

台灣力得衛宇龍科技股份有限公司

*單階材料用量清單

製表日期: 97-06-13

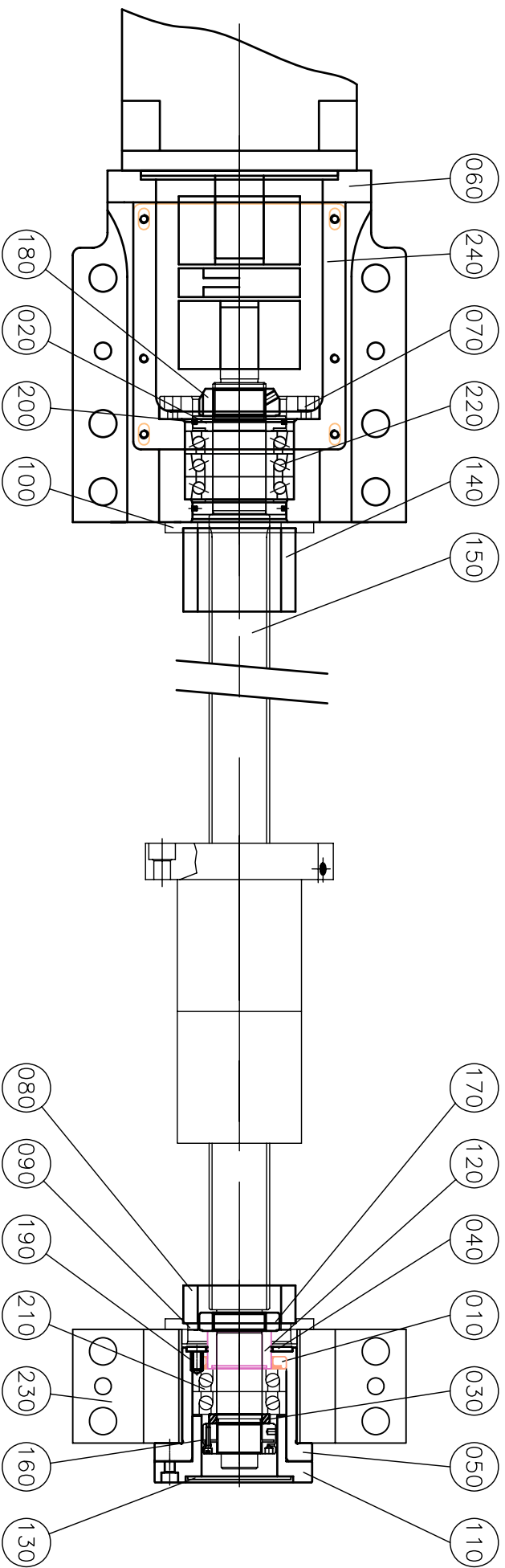

第1頁

主件品號	序號	元件品號	品名 英文品名	規 格	量
2F22013			Y軸傳動單元 Y AXIS TRANSMISSION UNIT	MV1100S/FAGOR/H.D.H	
	0010	3170053B0	軸承隔環 BEARING SPACER	3230\SCM4	1
	0020	3170054B0	前迷宮環座 LAMINAL RING BRACKET	3250\SCM4	2
	0030	3170057B0	軸承隔環 BEARING SPACER	3230\SCM4	1
	0040	3170067A0	預拉彈簧檔片 PRELOAD SPRING STOPPER	3230\S45C	1
	0050	3170070A0	Z軸尾端軸承座 REAR BEARING HOUSING	1080\S45C	1
	0060	3560098B0	傳動座(共用3560015A0木型) TRANSMISSION HOUSING	1080\FC-25	1
	0070	3560016B0	軸承壓蓋 BEARING CAP	3240\SCM4	1
	0080	3560017B0	防撞膠塊 RUBBER CUSHION	4370\PU	1
	0090	3560018F0	防撞膠塊固定座 RUBBER CUSHION BRACKET	3240\SCM4	1
	0100	3560019B0	防撞膠固定座 RUBBER CUSHION BRACKET	3230\S45C	1
	0110	3560023E0	Z軸尾端軸承座壓板 PUSHING PLATE, Z AXIS BEARING	3120\SCM4	1
	0120	3560024B0	軸承隔環 BEARING SPACER	3230\SCM4	1
	0130	3560132B0	尾端座蓋板 REAR BEARING HOUSING COVER	3180\SPCC	1
	0140	3560346A0	防撞膠塊 RUBBER CUSHION	4370\PU	1
	0150	3984010A0	滾珠螺桿 Y AXIS BALL SCREW	9860\40x1157LxP10	1
	0160	4020401030	鎖緊螺帽 LOCK UNT	MK30	1
	0170	4020402035	鎖緊螺帽 LOCK UNT	MR35(M35xP1.5)	1
	0180	4020403035	鎖緊螺帽 LOCK UNT	MF35(M35xP1.5)	1
	0190	4050175012	壓縮彈簧 COMPRESSIVE SPRING	φ 1.25X φ 7.5X12L	8
	0200	4061306828	迷宮環 LAMINAL RING	FK3-AS 62/2.8/0.82	6
	0210	4402030062	螺桿軸承 BALL SCREW BEARING	BS30M62/15-P4A.DUM	1
	0220	4402435072	螺桿軸承 BALL SCREW BEARING	BS35/72/15TUM	1
	0230	3560027B0	尾端座 REAR BEARING HOUSING	1080\FC-25	1
	0240	3560111B0	傳動座蓋板 TRANSMISSION HOUSING COVER	7180\SPCC	1



MV-1100S/MV-1100D(HDH, FAGOR)

Leaderway Machinery Co. Ltd.

Scale 1:4		Drawing Name Y-AXIS TRANSMISSION UNIT(Y軸傳動單元)		Page 1/1	
Drawn Control		Name 徐維駿 審核		Date 97.06.04 yy.mm.dd	
 		Draw No. 8120096C0(2F22013)			
				A4	

台灣力得衛宇龍科技股份有限公司

*單階材料用量清單

製表日期: 99-08-17

第1頁

主件品號	序號	元件品號	品名 英文品名	規 格	月量
2F22014			Y軸傳動單元 Y AXIS TRANSMISSION UNIT	MV-1300S/MV-1300D(H.D.H)	
	0010	3170044C0	壓縮彈簧座 COMPRESSIVE SPRING BRACKET	3240\S45C	1
	0020	3170054B0	前迷宮環座 LAMINAL RING BRACKET	3250\SCM4	3
	0030	3560017B0	防撞膠塊 RUBBER CUSHION	4370\PU	1
	0040	3560098B0	傳動座 TRANSMISSION HOUSING	1080\FC-25\3560015A2	1
	0050	3560016B0	軸承壓蓋 BEARING CAP	3240\SCM4	1
	0060	3560019B0	防撞膠固定座 RUBBER CUSHION BRACKET	3230\S45C	1
	0070	3560111B0	傳動座蓋板 TRANSMISSION HOUSING COVER	7180\SPCC	1
	0080	3570033B0	尾端座 REAR BEARING HOUSING	1080\FC-25\3560027A2	1
	0090	3570034B0	軸承壓蓋 BEARING CAP	3240\SCM4	1
	0100	3570035B0	隔環 SPACER	3230\SCM4	1
	0110	3570036C0	彈簧壓蓋 SPRING CAP	3240\S45C	1
	0120	3570037C0	防水隔環 SPACER	3230\SCM4	1
	0130	3570038B0	軸承座 BEARING HOUSING	3250\S45C	1
	0140	3570039A0	防撞膠固定座 RUBBER CUSHION BRACKET	3230\S45C	1
	0150	3570041A0	防撞膠墊 RUBBER CUSHION	4370\PU	1
	0160	3984019A0	滾珠螺桿 BALL SCREW	9860\φ 50xP10	1
	0170	4020403035	鎖緊螺帽 LOCK NUT	MF35(M35xP1.5)	1
	0180	4020403040	鎖緊螺帽 LOCK NUT	MF40	1
	0190	4020405035	鎖緊螺帽(軸向) AXIAL LOCK NUT	MKR-35 X1.5P	1
	0200	4050110032	壓縮彈簧 COMPRESSIVE SPRING	扁圓形 φ 10x32-1.8x1.1	6
	0210	4061306828	迷宮環 LAMINAL RING	FK3-AS 62/2.8/0.82	12
	0220	4402035072	螺桿軸承 BALL SCREW BEARING		1
	0230	4402435072	螺桿軸承 BALL SCREW BEARING	BS35/72/15TUM	1

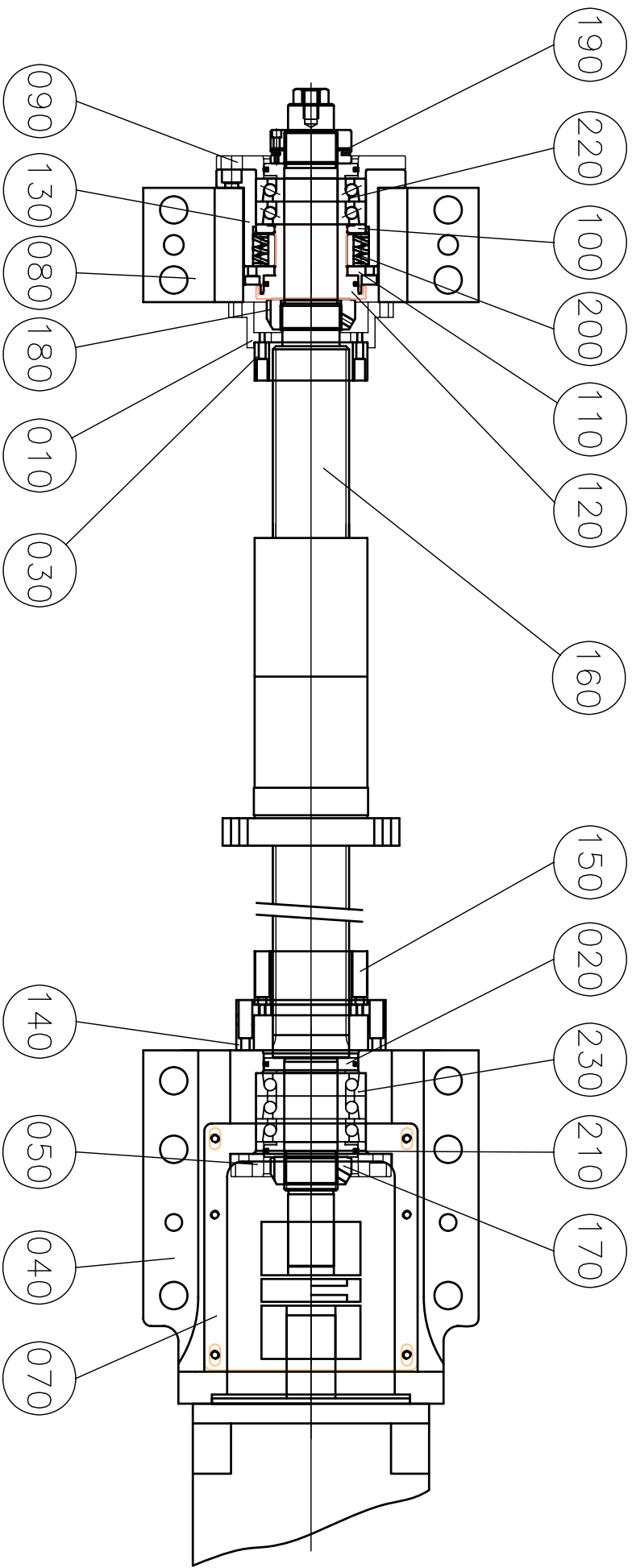

MV-1300S/MV-1300D(HDH)

Leaderway Machinery Co. Ltd.

Scale 1:4		Drawing Name Y-AXIS TRANSMISSION UNIT(Y軸傳動單元)		Page 1/1
Drawn Control	Name 徐維駿 審核	Date 97.06.04 yy.mm.dd	Draw No. 8120224B0(2F22014)	A4



台灣力得衛宇龍科技股份有限公司

*單階材料用量清單

製表日期: 97-06-26

第1頁

主件品號	序號	元件品號	品名 英文品名	規 格	月量
2F23003			Z軸傳動單元 Z AXIS TRANSMISSION UNIT	MV-1100S/MV-1300S	
	0011	3170053B0	軸承隔環 BEARING SPACER	3230\SCM4	1
	0021	3170054B0	前迷宮環座 LAMINAL RING BRACKET	3250\SCM4	2
	0031	3170057B0	軸承隔環 BEARING SPACER	3230\SCM4	1
	0040	3170070A0	Z軸尾端軸承座 REAR BEARING HOUSING	1080\S45C	1
	0050	3170074C0	Z軸軸承座防撞膠塊 RUBBER CUSHION	4370\PU	1
	0060	3560015C0	傳動座 TRANSMISSION HOUSING	1080\FC-25	1
	0071	3560016B0	軸承壓蓋 BEARING CAP	3240\SCM4	1
	0080	3560479A0	防撞膠塊 RUBBER CUSHION	4370\PU	1
	0090	3560019B0	防撞膠固定座 RUBBER CUSHION BRACKET	3230\S45C	2
	0101	3560021B0	軸承隔環 BEARING SPACER	3230\SCM4	1
	0110	3560022A0	預拉彈簧擋片 PRELOAD SPRING STOPPER	3230\S45C	1
	0121	3560023E0	Z軸尾端軸承座壓板 PUSHING PLATE, BEARING HOUSING(Z)	3120\SCM4	1
	0130	3560132B0	尾端座蓋板 REAR BEARING HOUSING COVER	3180\SPCC	1
	0140	3984011A0	滾珠螺桿 Z AXIS BALL SCREW	9860\ φ 40xP10	1
	0150	4020401030	鎖緊螺帽 LOCK UNT	MK30	1
	0160	4020402035	鎖緊螺帽 LOCK UNT	MR35(M35xP1.5)	1
	0170	4020403035	鎖緊螺帽 LOCK UNT	MF35(M35xP1.5)	1
	0180	4050175012	壓縮彈簧 COMPRESSIVE SPRING	φ 1.25X φ 7.5X12L	8
	0190	4061306828	迷宮環 LAMINAL RING	FK3-AS 62/2.8/0.82	6
	0200	4402030062	螺桿軸承 BALL SCREW BEARING	BS30M62/15-P4A.DUM	1
	0210	4402435072	螺桿軸承 BALL SCREW BEARING	BS35/72/15TUM	1
	0220	3560027B0	尾端座 REAR BEARING HOUSING	1080\FC-25	1
	0230	3560111B0	傳動座蓋板 TRANSMISSION HOUSING COVER	7180\SPCC	1

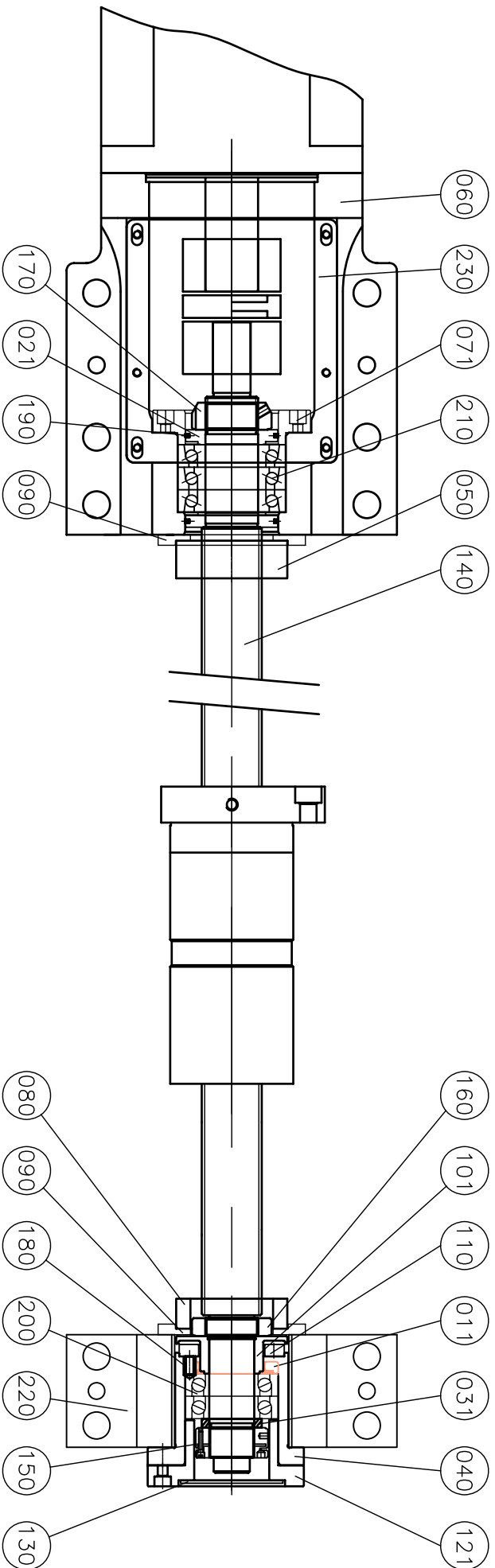

MV-1100S/MV-1300S

Leaderway Machinery Co. Ltd.

Scale		Drawing Name		Page	
1:4		Z-AXIS TRANSMISSION UNIT(Z軸傳動單元)		1/1	
Drawn		Name		Draw No.	
Control		徐維駿		8120145B0(2F23003)	
		審核			
		Date			
		97.05.30			
		yy.mm.dd			

A4

台灣力得衛宇龍科技股份有限公司

*單階材料用量清單

製表日期: 99-08-17

第1頁

主件品號	序號	元件品號	品名 英文品名	規 格	月量
2F23011			Z軸傳動單元 Z AXIS TRANSMISSION UNIT	MV1100S/FAGOR/H.D.H	
	0010	3170053B0	軸承隔環 BEARING SPACER	3230\SCM4	1
	0020	3170054B0	前迷宮環座 LAMINAL RING BRACKET	3250\SCM4	2
	0030	3170057B0	軸承隔環 BEARING SPACER	3230\SCM4	1
	0040	3170070A0	Z軸尾端軸承座 REAR BEARING HOUSING	1080\S45C	1
	0050	3170074C0	Z軸軸承座防撞膠塊 RUBBER CUSHION	4370\PU	1
	0060	3560098B0	傳動座 TRANSMISSION HOUSING	1080\FC-25\3560015A2	1
	0070	3560016B0	軸承壓蓋 BEARING CAP	3240\SCM4	1
	0080	3560479A0	防撞膠塊 RUBBER CUSHION	4370\PU	1
	0090	3560019B0	防撞膠固定座 RUBBER CUSHION BRACKET	3230\S45C	2
	0100	3560021B0	軸承隔環 BEARING SPACER	3230\SCM4	1
	0110	3560022A0	預拉彈簧擋片 PRELOAD SPRING STOPPER	3230\S45C	1
	0120	3560023E0	Z軸尾端軸承座壓板 PUSHING PLATE, BEARING HOUSI	3120\SCM4	1
	0130	3560132B0	尾端座蓋板 REAR BEARING HOUSING COVER	3180\SPCC	1
	0140	3984011A0	滾珠螺桿 Z AXIS BALL SCREW	9860\ φ 40xP10	1
	0150	4020401030	鎖緊螺帽 LOCK NUT	MK30	1
	0160	4020402035	鎖緊螺帽 LOCK NUT	MR35(M35xP1.5)	1
	0170	4020403035	鎖緊螺帽 LOCK NUT	MF35(M35xP1.5)	1
	0180	4050175012	壓縮彈簧 COMPRESSIVE SPRING	φ 1.25X φ 7.5X12L	8
	0190	4061306828	迷宮環 LAMINAL RING	FK3-AS 62/2.8/0.82	6
	0200	4402030062	螺桿軸承 BALL SCREW BEARING	BS30M62/15-P4A.DUM	1
	0210	4402435072	螺桿軸承 BALL SCREW BEARING	BS35/72/15TUM	1
	0220	3560027B0	尾端座 REAR BEARING HOUSING	1080\FC-25\3560027A2	1
	0230	3560111B0	傳動座蓋板 TRANSMISSION HOUSING COVER	7180\SPCC	1

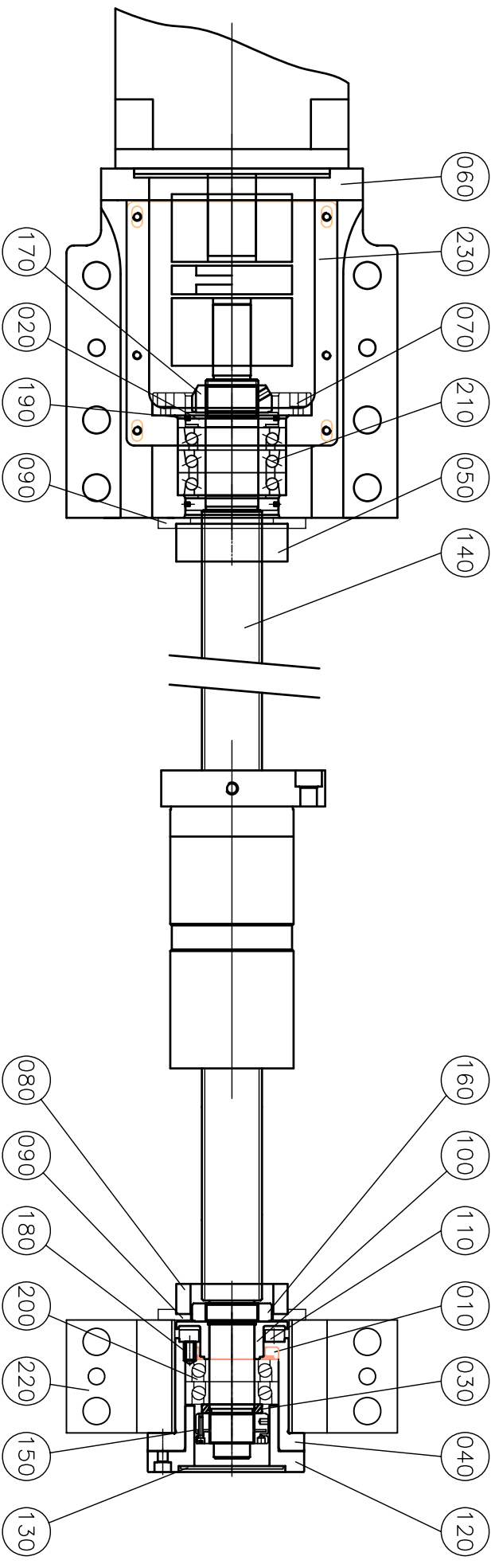

MV-1100S/MV-1300S(HDH,FAGOR)

Leaderway Machinery Co. Ltd.

Scale 1:4		Drawing Name Z-AXIS TRANSMISSION UNIT(Z軸傳動單元)		Page 1/1
Drawn Control	Name 徐維駿 審核	Date 97.06.04 yy.mm.dd	Draw No. 8120097C0(2F23011)	A4

台灣力得衛宇龍科技股份有限公司

*單階材料用量清單

製表日期: 99-08-17

第1頁

主件品號	序號	元件品號	品名 英文品名	規 格	月量
2F23012			Z軸傳動單元 Z AXIS TRANSMISSION UNIT	MV1100D/MV1300D(H.D.H)	
	0010	3170053B0	軸承隔環 BEARING SPACER	3230\SCM4	1
	0020	3170054B0	前迷宮環座 LAMINAL RING BRACKET	3250\SCM4	2
	0030	3170057B0	軸承隔環 BEARING SPACER	3230\SCM4	1
	0040	3170070A0	Z軸尾端軸承座 REAR BEARING HOUSING	1080\S45C	1
	0050	3560098B0	傳動座 TRANSMISSION HOUSING	1080\FC-25\3560015A2	1
	0060	3560016B0	軸承壓蓋 BEARING CAP	3240\SCM4	1
	0070	3560019B0	防撞膠固定座 RUBBER CUSHION BRACKET	3230\S45C	2
	0080	3560021B0	軸承隔環 BEARING SPACER	3230\SCM4	1
	0090	3560022A0	預拉彈簧擋片 PRELOAD SPRING STOPPER	3230\S45C	1
	0100	3560023E0	Z軸尾端軸承座壓板 PUSHING PLATE,BEARING HOUSI	3120\SCM4	1
	0110	3560132B0	尾端座蓋板 REAR BEARING HOUSING COVER	3180\SPCC	1
	0120	3560373A0	防撞膠塊 RUBBER CUSHION	4370\PU	1
	0130	3560374A0	防撞膠塊 RUBBER CUSHION	4370\PU	1
	0140	3984011A0	滾珠螺桿 Z AXIS BALL SCREW	9860\ φ 40xP10	1
	0150	4020401030	鎖緊螺帽 LOCK NUT	MK30	1
	0160	4020402035	鎖緊螺帽 LOCK NUT	MR35(M35xP1.5)	1
	0170	4020403035	鎖緊螺帽 LOCK NUT	MF35(M35xP1.5)	1
	0180	4050175012	壓縮彈簧 COMPRESSIVE SPRING	φ 1.25X φ 7.5X12L	8
	0190	4061306828	迷宮環 LAMINAL RING	FK3-AS 62/2.8/0.82	6
	0200	4402030062	螺桿軸承 BALL SCREW BEARING	BS30M62/15-P4A.DUM	1
	0210	4402435072	螺桿軸承 BALL SCREW BEARING	BS35/72/15TUM	1
	0220	3560027B0	尾端座 REAR BEARING HOUSING	1080\FC-25\3560027A2	1
	0230	3560111B0	傳動座蓋板 TRANSMISSION HOUSING COVER	7180\SPCC	1

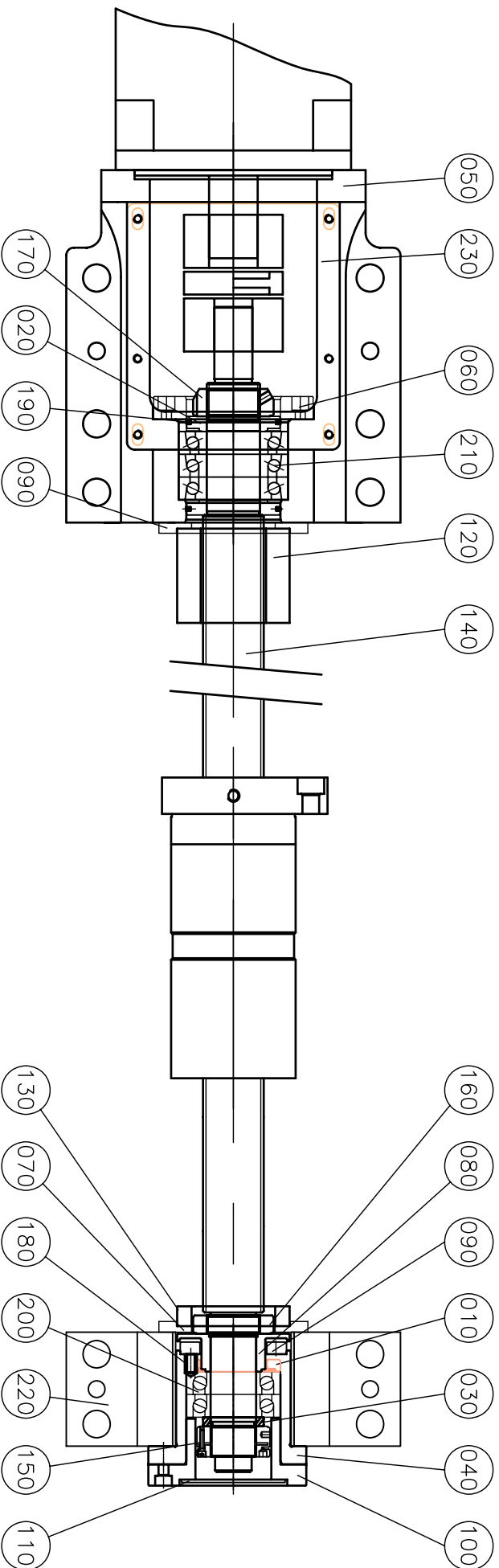

MV-1100D/MV-1300D(HDH)

Leaderway Machinery Co. Ltd.

Scale 1:4		Drawing Name Z-AXIS TRANSMISSION UNIT(Z軸傳動單元)		Page 1/1
Drawn Control	Name 徐維駿 審核	Date 97.06.04 yy.mm.dd	Draw No. 8120225B0(2F23012)	A4

台灣力得衛宇龍科技股份有限公司

*單階材料用量清單

製表日期: 99-08-17

第1頁

主件品號	序號	元件品號	品名 英文品名	規 格	月量
2F27001			打刀單元 BOSSTING CYLINDER UNIT	V-1100/MV-1100S	
	0011	3500019B0	固定軸套 FIXED ROD	3290\S45C	4
	0020	3560045A0	打刀缸支柱 BOOSTING CYLINDER SUPPORTING	3300\六角鐵	4
	0030	3560046B0	固定座 BRACKET	3180\SS41	1
	0040	3560047A0	增壓缸固定座 TOOL RELEASE CYLINDER BRACKE	3180\SS41	1
	0050	3560182A0	浮動打刀拉座 TOOL RELEASE CYLINDER SEAT	3250\S45C	1
	0060	3980001A0	增壓缸(3Tx13L) TOOL RELEASE CYLINDER	9880	1

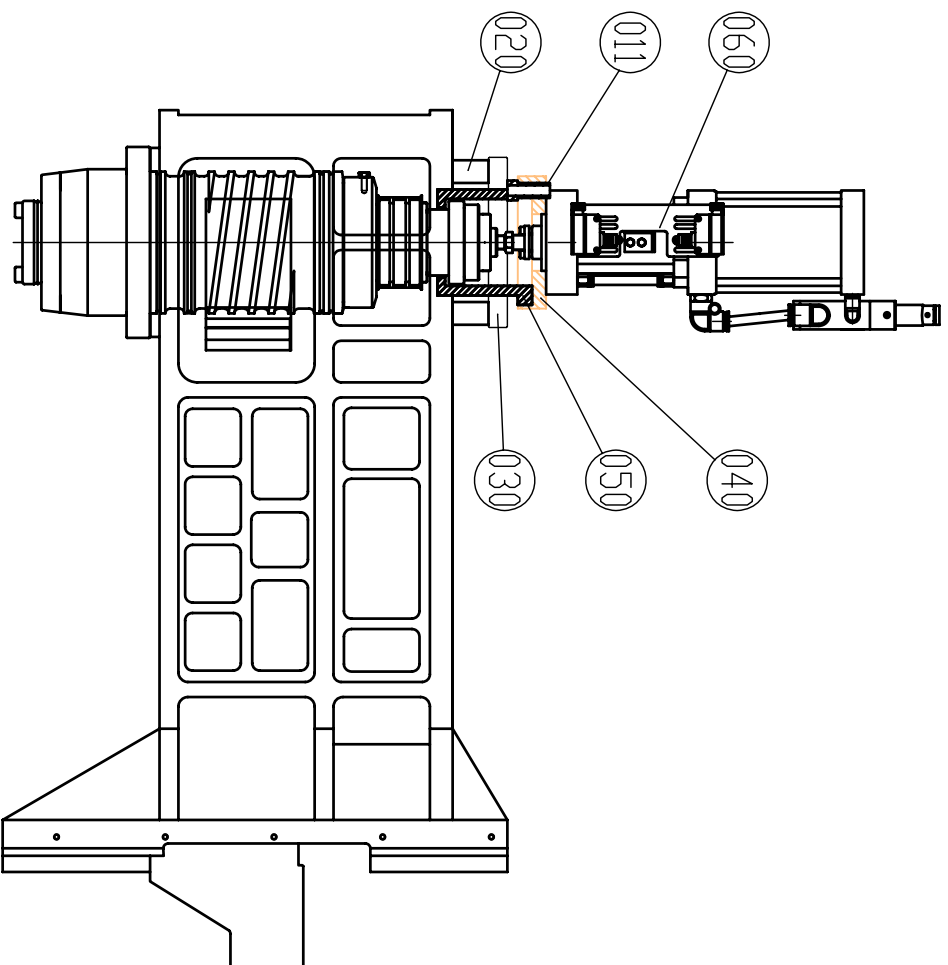
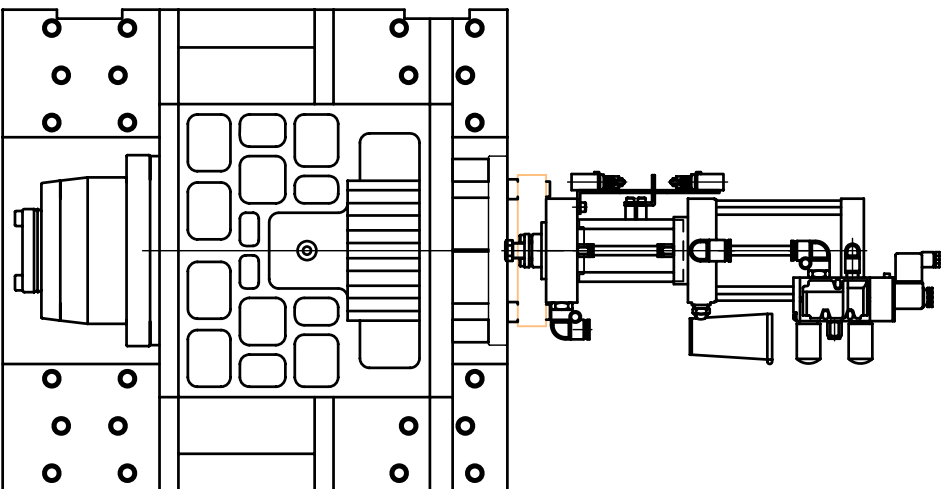

V-1100\MV-1100S\MV-1300S

Leaderway Machinery Co. Ltd.

Scale		Drawing Name		Page	
1:8		打刀單元 ROSSING CYLINDER UNIT		1/1	
Drawn		Date		A4	
Control		yy. mm. dd		8120389A0(2F27001)	
徐維駿		97.06.02			
審核		yy. mm. dd			

台灣力得衛宇龍科技股份有限公司

*單階材料用量清單

製表日期: 99-08-17

第1頁

主件品號	序號	元件品號	品名 英文品名	規 格	月量
2F27014			打刀單元(CTS) BOOSTING CYLINDER UNIT	取消此單元改用2F27023單元	
	0010	3980001A0	增壓缸(3Tx13L) TOOL RELEASE CYLINDER	9880	1
	0020	3560393A0	打刀缸支柱 BOOSTING CYLINDER SUPPORTING	3300\六角鐵	4
	0031	3560394A0	固定座 BRACKET	3180\SS41	1
	0050	4250200302	梭動閥(3口2位止回閥) CHECK VALVE	TXLT/3(CTS功能使用)	1
	0060	4220021814	直型雙外牙鐵接頭 STRAIGHT MALE STUD	1/8"PTx1/4"H	1
	0070	4180014040	直型高壓油管 HIGH-PRESSURE HOSE	1/4"R1x400L	1
	0080	4220623814	L型雙外牙鐵接頭 MALE STUD ELBOW	3/8"PT-1/4"H	1
	0090	4180038800	直型高壓油管 HIGH-PRESSURE HOSE	3/8"R1x8000L	1
	0100	3560045A0	打刀缸支柱 BOOSTING CYLINDER SUPPORTING	3300\六角鐵	4

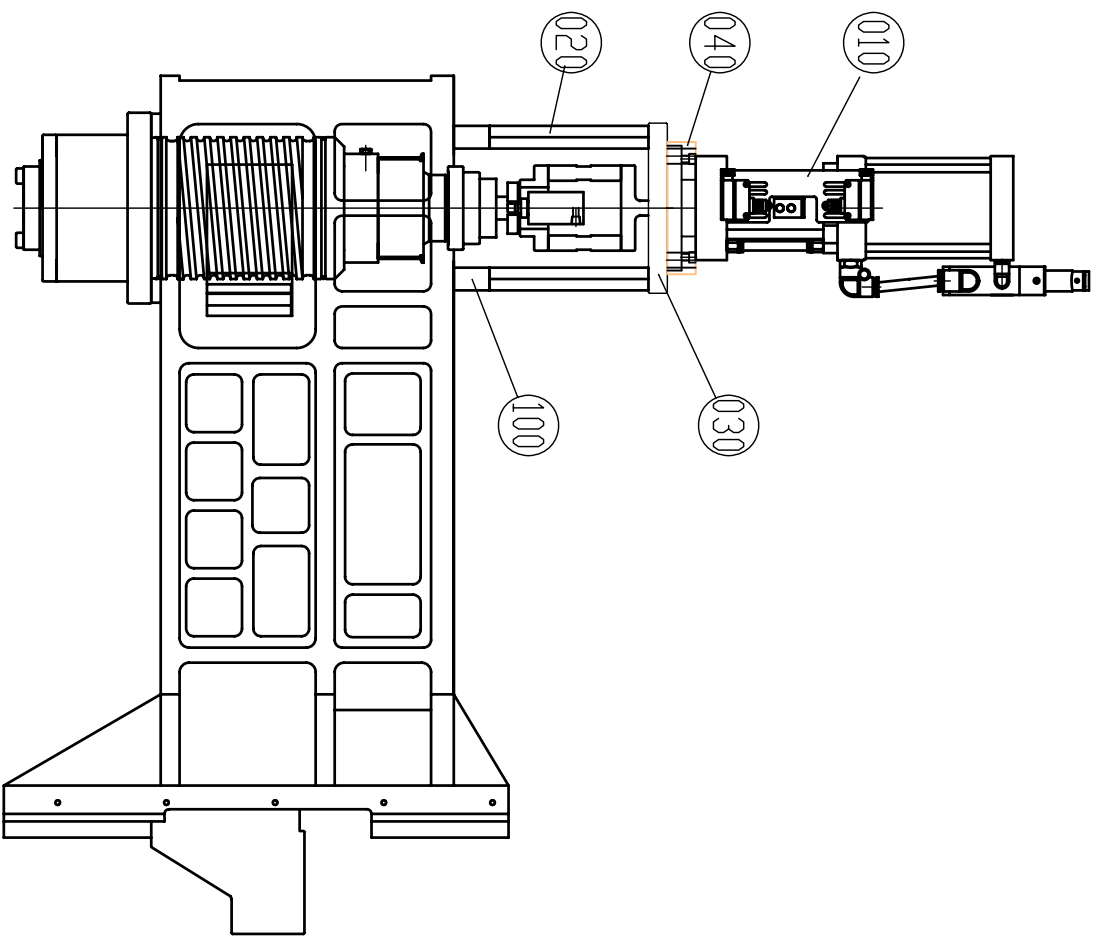
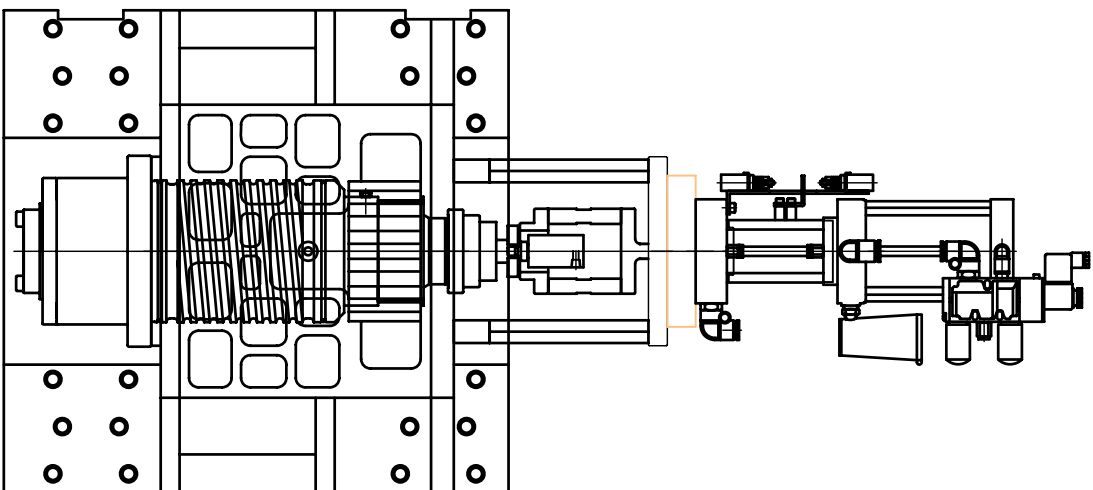

V-1100\MV-1100S\MV-1300S

Leaderway Machinery Co. Ltd.

Scale		Drawing Name		Page	
1:8		打刀單元(CTS) BOSSTING CYLINDER UNIT(CTS)		1/1	
Drawn		Date		Draw No.	
Control		yy.mm.dd		8120262B0(2F27014)	
徐維駿		97.06.02			
審核					

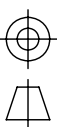

台灣力得衛宇龍科技股份有限公司

*單階材料用量清單

製表日期: 99-08-17

第1頁

主件品號	序號	元件品號	品名 英文品名	規 格	月量
2F27003			打刀單元 BOSSTING CYLINDER UNIT	MV1100D/MV1300D	
	0010	3560372A0	浮動打刀拉座 TOOL RELEASE CYLINDER SEAT	3250\S45C	1
	0022	3570046A0	打刀缸座 CYLINDER SEAT	3180\SS41	1
	0030	3570050A0	打刀缸支架 BOOSTING CYLINDER SUPPORTING	3300\S45C	4
	0042	3980025A0	打刀缸組件 TOOL RELEASE CYLINDER	9880\4Tx17L	1

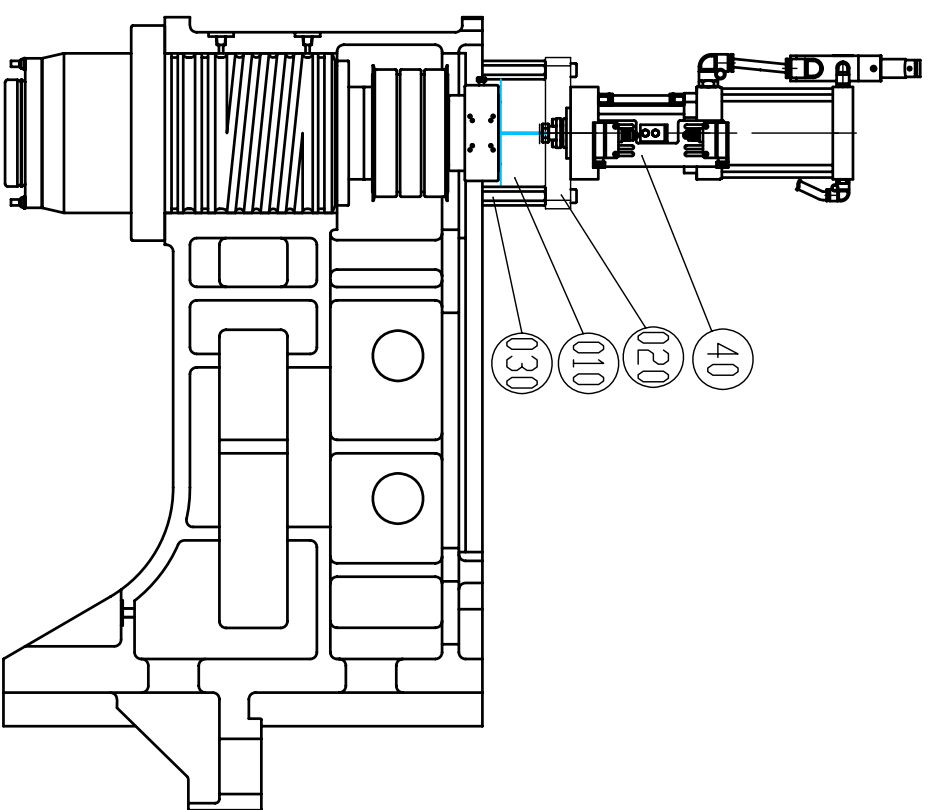
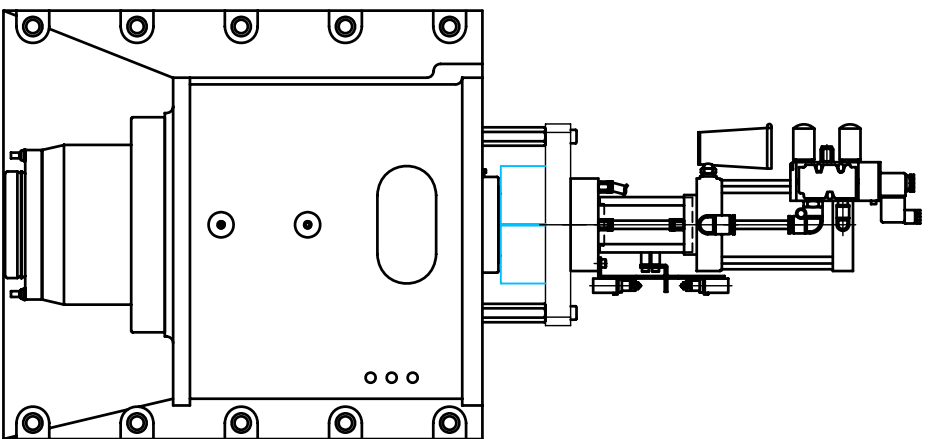

MV-1100D\MV-1300D

Leaderway Machinery Co. Ltd.

Scale		Drawing Name		Page	
1:9		打刀單元 BOSSING CYLINDER UNIT		1/1	
Drawn		Date		A4	
Control		97.06.02		8120390A0(2F27003)	
Name		Draw No.			
洪文昇					

台灣力得衛宇龍科技股份有限公司

*單階材料用量清單

製表日期: 99-08-17

第1頁

主件品號	序號	元件品號	品名 英文品名	規 格	月量
2F27016			打刀單元(CTS) BOSSTING CYLINDER UNIT	MV1100D/MV1300D	
	0010	3980025A0	打刀缸組件 TOOL RELEASE CYLINDER	9880\4Tx17L	1
	0021	3560496B0	打刀缸支架 BOOSTING CYLINDER SUPPORTING	3300\六角鐵	4
	0030	3570046A0	打刀缸座 CYLINDER SEAT	3180\SS41	1
	0040	4250200302	梭動閥(3口2位止回閥) CHECK VALVE	TXLT/3(CTS功能使用)	1
	0050	4220021814	直型雙外牙鐵接頭 STRAIGHT MALE STUD	1/8"PTx1/4"H	1
	0060	4180014040	直型高壓油管 HIGH-PRESSURE HOSE	1/4"R1x400L	1
	0070	4220623814	L型雙外牙鐵接頭 MALE STUD ELBOW	3/8"PT-1/4"H	1
	0080	4180038800	直型高壓油管 HIGH-PRESSURE HOSE	3/8"R1x8000L	1

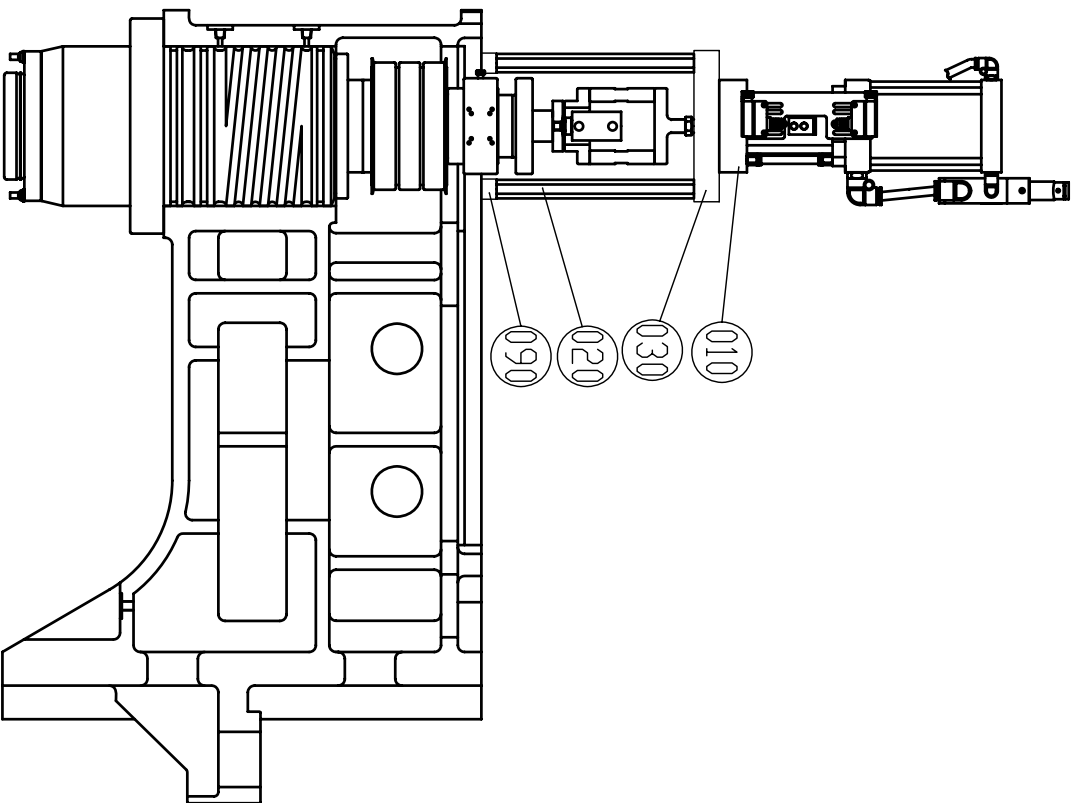
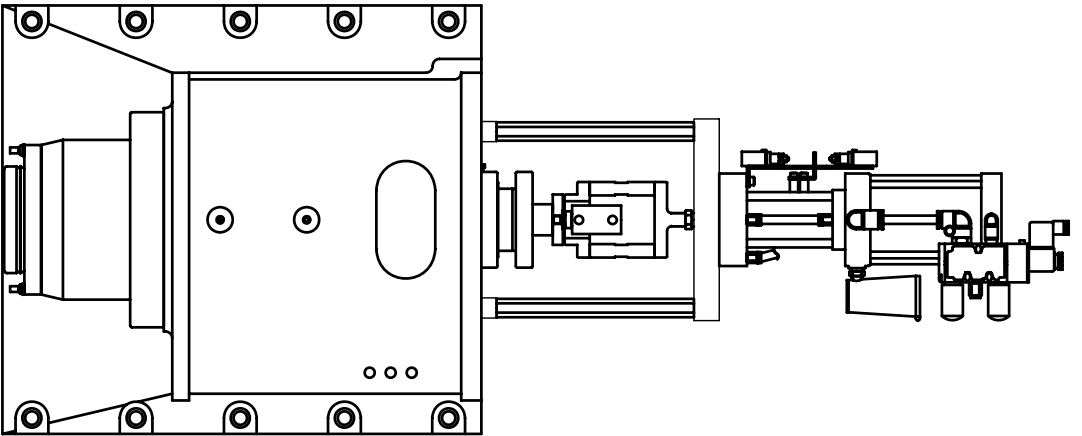

MV-1100D\MV-1300D

Leaderway Machinery Co. Ltd.

Scale		Drawing Name		Page	
1:9		打刀單元(CTS) BOSSTING CYLINDER UNIT(CTS)		1/1	
Drawn		Name		A4	
Control		洪文昇		Date	
		97.06.02		Draw No.	
				8120391A0(2F27016)	

台灣力得衛宇龍科技股份有限公司

*單階材料用量清單

製表日期: 99-08-17

第1頁

主件品號	序號	元件品號	品名 英文品名	規 格	月量
2F28001			主軸皮帶輪單元 SPINDLE BELT UNIT	V1100/MV1100S/F α 15/10K	
	0010	3560318B0	主軸馬達調整板 ADJUSTABLE PLATE	3170\SS41	1
	0020	3971020A0	主軸馬達皮帶輪 PULLEY	3270\S45C(5GT/60T/φ 48)	1
	0030	3600135A0	軸壓蓋(φ 48) SHAFT END COVER	3240\S45C	1
	0040	4061248055	迫緊環 PACKING RING	TLK300 48x55	3
	0050	3600137A0	隔環(φ 48) SPACER	3230\S45C	2
	0061	4601040935	齒型皮帶(剖溝) PULLEY BELT	5GT*40*935	1

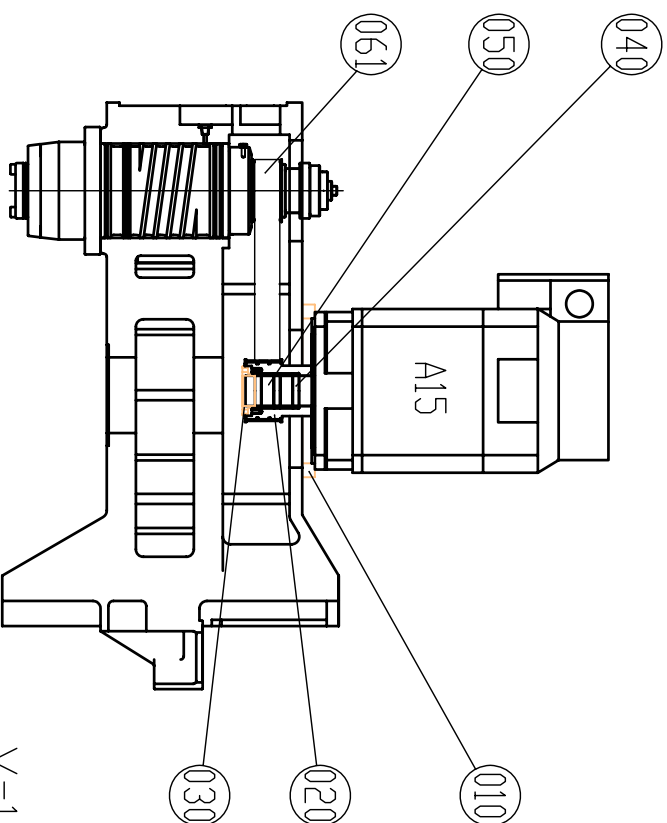
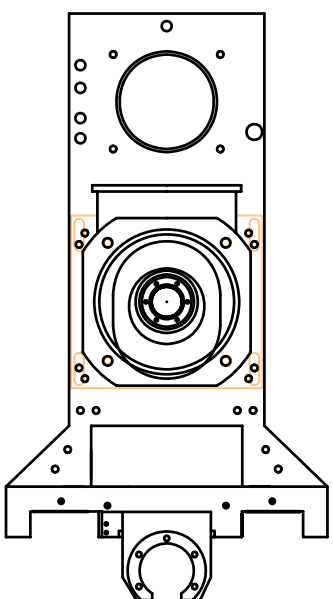

V-1100\MV-1100S\MV-1300S

Leaderway Machinery Co. Ltd.

Scale		Drawing Name		Page	
1:12		主軸皮帶輪單元 SPINDLE BELT UNIT		1/1	
Drawn		Name		Date	
Control		徐維駿 審核		97.06.06	
		Draw No.		Unit	
		8120175B0 (2F28001)		yy. mm. dd	
				A4	



台灣力得衛宇龍科技股份有限公司

*單階材料用量清單

製表日期: 97-06-13

第1頁

主件品號	序號	元件品號	品名 英文品名	規 格	日量
2F28014			主軸皮帶輪單元 SPINDLE BELT UNIT	V1100/MV1100S/F α 15/8K	
	0010	3560318B0	主軸馬達調整板 ADJUSTABLE PLATE	3170\SS41	1
	0020	3971038A0	齒型皮帶輪(8YU/48T- φ 48) PULLEY	3270\S45C	1
	0030	3600135A0	軸壓蓋(φ 48) SHAFT END COVER	3240\S45C	1
	0040	4061248055	迫緊環 PACKING RING	TLK300 48x55	3
	0050	3600137A0	隔環(φ 48) SPACER	3230\S45C	2
	0061	4600351016	齒型皮帶 PULLEY BELT	8YU-1016-35	1

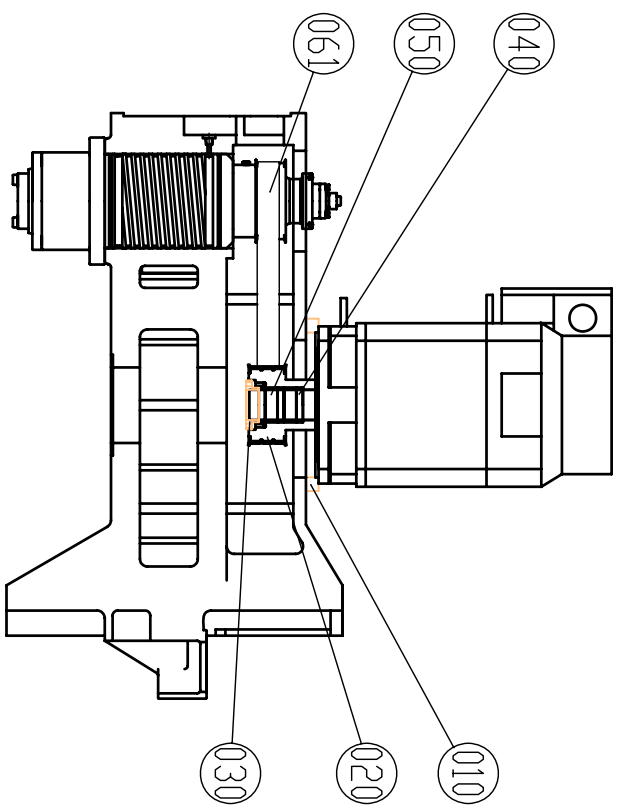
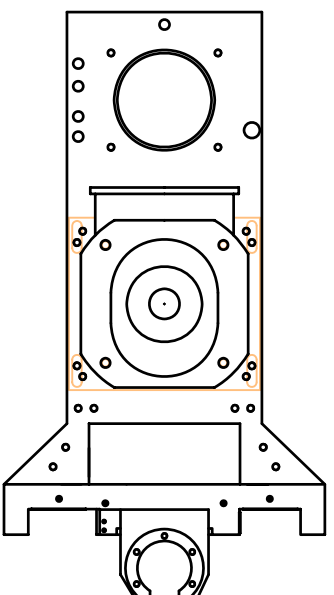

V-1100\MV-1100S

Leaderway Machinery Co. Ltd.

Scale		Drawing Name		Page	
1:1		主軸皮帶輪單元 SPINDLE BELT UNIT		1/1	
Drawn		Name		A4	
Control		徐維駿			
		審核			
		DATE		Draw No.	
		97.06.06		8120163B0 (2F28014)	
		y.y. mm. dd			

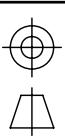

台灣力得衛宇龍科技股份有限公司

*單階材料用量清單

製表日期: 97-06-13

第1頁

主件品號	序號	元件品號	品名 英文品名	規 格	日量
2F28018			主軸皮帶輪單元 SPINDLE BELT UNIT	V-1100S/MV-1100S	
	0010	3560318B0	主軸馬達調整板 ADJUSTABLE PLATE	3170\SS41	1
	0020	3971016A0	齒型皮帶輪(5GT-75T) PULLEY	3270\V1100	1
	0030	3560044A0	馬達軸端蓋 SHAFT END COVER	3170\S45C	1
	0042	4600240970	齒型皮帶 PULLEY BELT	5GT-970-40	1

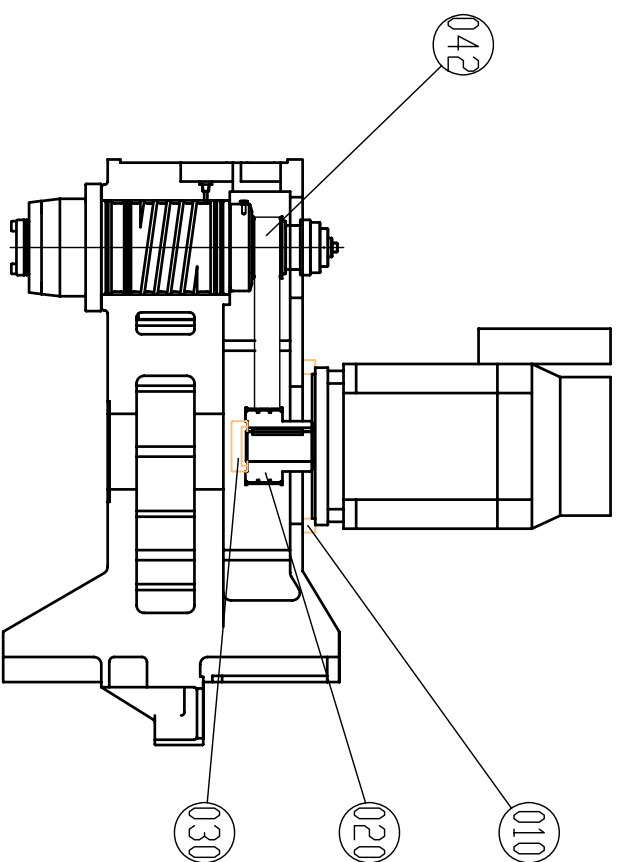
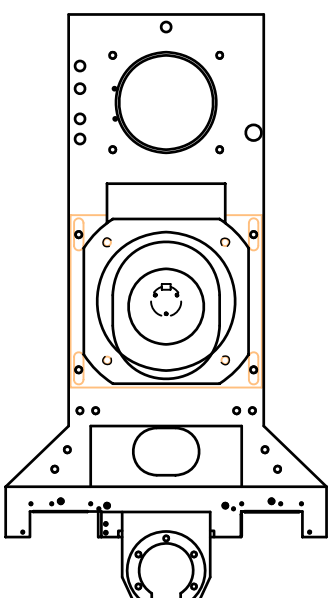

V-1100\MV-1100S

Leaderway Machinery Co. Ltd.

Scale		Drawing Name		Page	
1:12		主軸皮帶輪單元 SPINDLE BELT UNIT		1/1	
Drawn		Date		Draw No.	
Control		yv. mm. dd		8120173B0 (2F28018)	
徐維駿		97.06.06			
審核					

A4

台灣力得衛宇龍科技股份有限公司

*單階材料用量清單

製表日期: 97-06-13

第1頁

主件品號	序號	元件品號	品名 英文品名	規 格	日量
2F28022			主軸皮帶輪單元 SPINDLE BELT UNIT	MV1100S/1300S HDH 260M	
	0010	3560105B0	主軸馬達調整板 ADJUSTABLE PLATE	3170\SS41	1
	0021	3971052A0	齒型皮帶輪(8YU-48T) PULLEY	3270\S45C	1
	0030	4061242055	迫緊環 PACKING RING	TOLLOK 42x55	1
	0042	4600351016	齒型皮帶 PULLEY BELT	8YU-1016-35	1
	0050	3560583A0	墊塊 PAD	3310\SS41	4

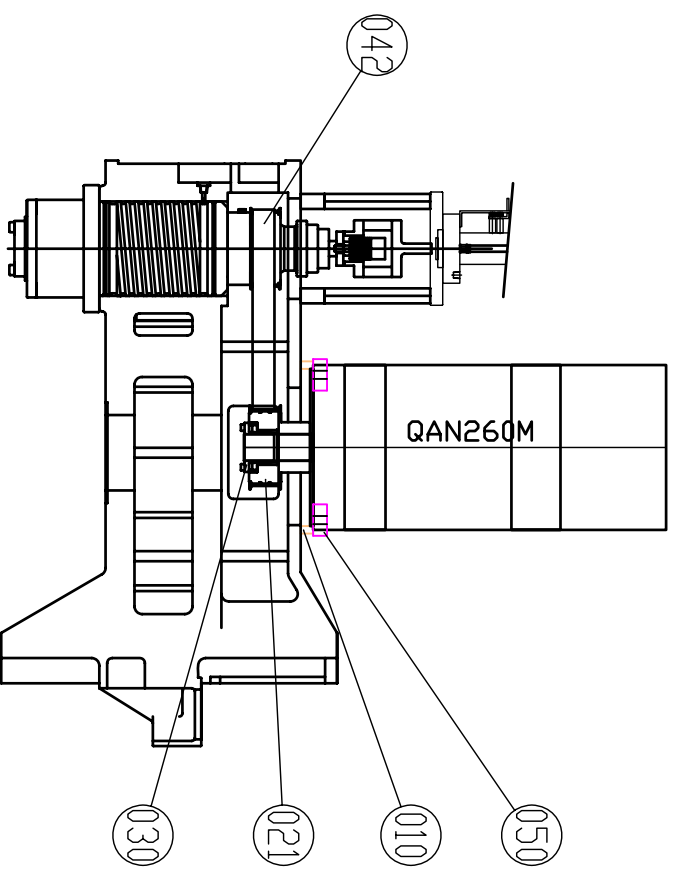
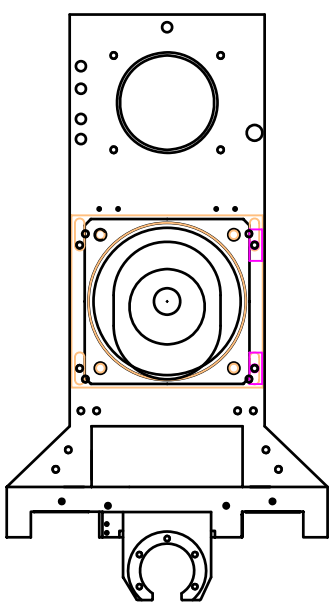

V-1100\MV-1100S\MV-1300S

Leaderway Machinery Co. Ltd.

Scale		Drawing Name		Page	
1:12		主軸皮帶輪單元 SPINDLE BELT UNIT		1/1	
Drawn		Name		A4	
Control		Date		Draw No.	
徐維駿		97.06.09		8120361A0(2F28022)	
審核		yy.mm.dd			



台灣力得衛宇龍科技股份有限公司

*單階材料用量清單

製表日期: 99-08-17

第1頁

主件品號	序號	元件品號	品名 英文品名	規 格	月量
2F28024			主軸皮帶輪單元(G-B) SPINDLE BELT UNIT	MV1100S-MV1300S+Gear Box	
	0010	3980029A0	ZF齒輪箱組件 GEAR BOX UNIT	9270\LDV-3220	1
	0021	3570129B0	馬達整調板 ADJUSTABLE PLATE	3170\SS41	1
	0030	3971046A0	齒型皮帶輪(8YU/56T-φ48) PULLEY	3270\S45C	1
	0041	4600401080	齒型皮帶 PULLEY BELT	8YU-1080-40	1
	0051	4430412221	定積脫壓給油泵浦 LUBRICANT PUMP	MS-12W-220V單相-總高345	1
	0060	4510100001	油表 COOLANT LEVEL GAUGE	3''	1
	0071	3560596B0	油槽 OIL TROUGH	7520\SPCC	1
	0081	3570131C0	蓋板(油槽) OIL TROUGH COVER	7540\SPCC	1
	0090	4800408508	浮動開關含接桿 FLOATING SWITCH	M8-P=1.25/85L	1
	0110	3560597A0	銅管組 COPPER TUBING	4420\3/8銅管	1
	0120	3603203B0	管接頭 CONNECTOR	3240\SS41	1
	0130	4710021424	繼電器附燈 RELAY	MY-2NJ DC24V	2
	0140	4712081520	繼電器座 RELAY BRACKET	PYF-08A-E-T OMB	2
	0151	4710201901	電磁接觸器 ELECTROMAGNETIC CONTACTOR	DILM901D1	1
	0160	4721480633	歐式端子台 TERMINAL BLOCK	280-633	2
	0170	4721880314	端子台側板 SIDE PLATE, TERMINAL BLOCK	WAGO 280-314	1
	0180	4722349117	終端檔塊 STOPPER	WAGO 249-117	2
	0190	4710800106	線路保護器 LINE PROTECTION	FAZNS1P6A	1
	0200	4710315024	電源供應器 POWER SUPPLY	S150-24V(6.5A)	1
	0210	4510120001	塑膠油杯 OIL-TANK		1

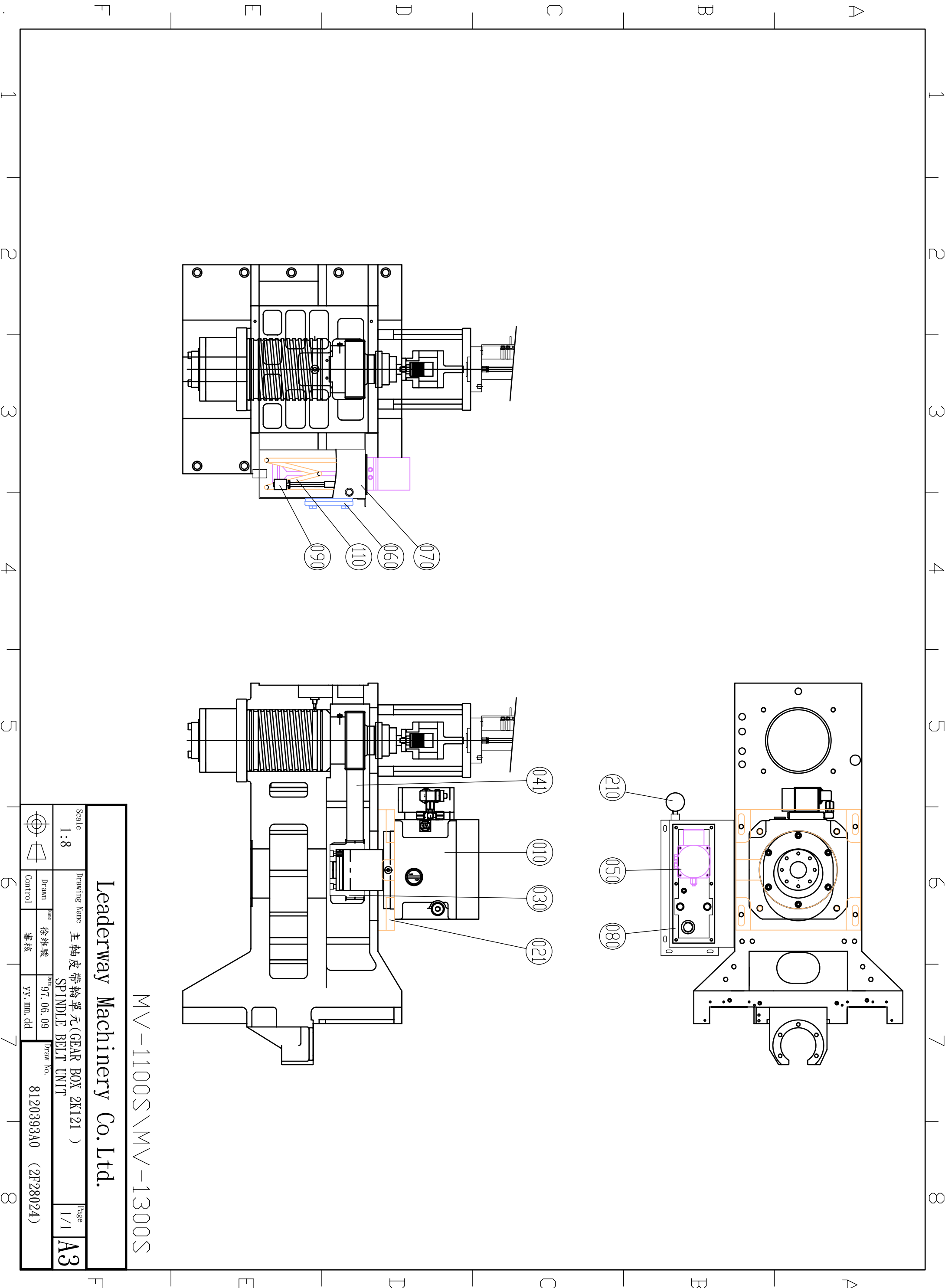

MV-1100S\MV-1300S

Leaderway Machinery Co. Ltd.

Scale		Drawing Name		Page	
1:8		主軸皮帶輪單元(GEAR BOX 2K121) SPINDLE BELT UNIT		1/1	
Drawn	Checked	Draw No.	8120393A0 (2F28024)		
Control	審核	YY. mm. dd			
		97. 06. 09			

台灣力得衛宇龍科技股份有限公司

*單階材料用量清單

製表日期: 99-08-17

第1頁

主件品號	序號	元件品號	品名 英文品名	規 格	月量
2F28004			主軸皮帶輪單元 SPINDLE BELT UNIT	MV1100D/MV1300D	
	0010	3560318B0	主軸馬達調整板 ADJUSTABLE PLATE	3170\SS41	1
	0020	3971032A0	齒型皮帶輪(8YU/45T) PULLEY	3270\S45C	1
	0030	3600135A0	軸壓蓋(\$ 48) SHAFT END COVER	3240\S45C	1
	0040	4061248055	迫緊環 PACKING RING	TLK300 48x55	3
	0050	3600137A0	隔環(\$ 48) SPACER	3230\S45C	2
	0060	4600501128	齒型皮帶 PULLEY BELT	8YU-1128-50	1

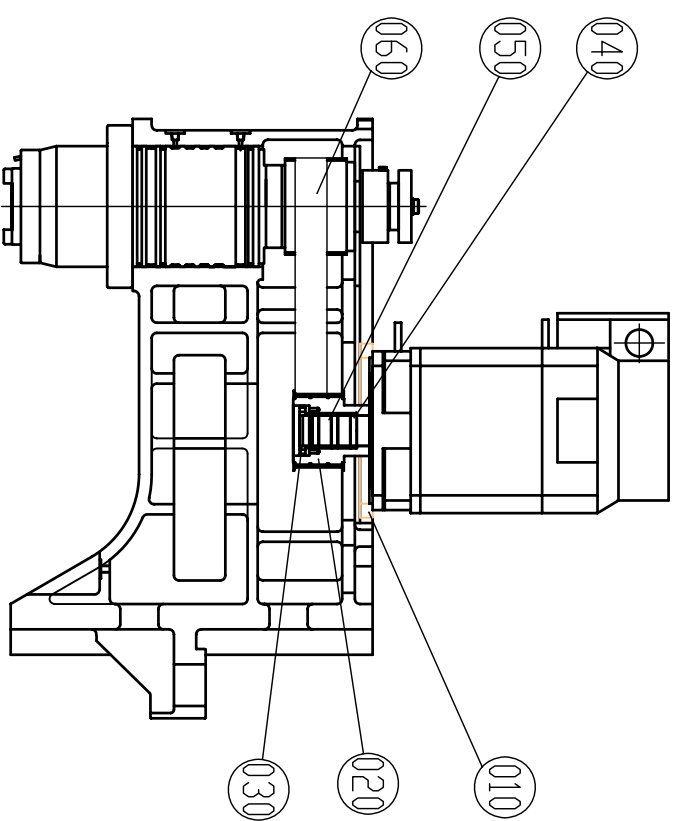
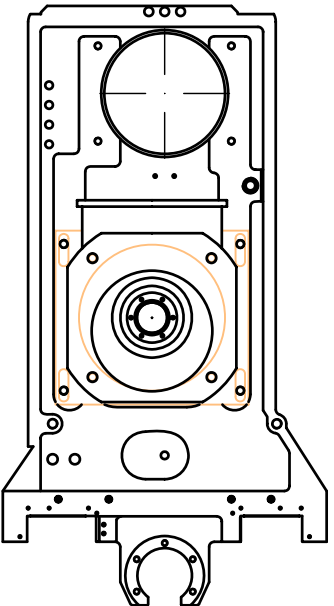

MV-1100D\MV-1300D

Leaderway Machinery Co. Ltd.

Scale		Drawing Name		Page	
1:12		主軸皮帶輪單元 SPINDLE BELT UNIT		1/1 A4	
Drawn	Name	Date	Draw No.		
Control	徐維駿	97.06.03	8120150B0(2F28004)		
	審核	yy.mm.dd			



台灣力得衛宇龍科技股份有限公司

*單階材料用量清單

製表日期: 99-08-17

第1頁

主件品號	序號	元件品號	品名 英文品名	規 格	月量
2F28016			主軸皮帶輪單元(G-B) SPINDLE BELT UNIT	MV1100D-MV1300D+Gear Box	
	0010	3980029A0	ZF齒輪箱組件 GEAR BOX UNIT	9270\LDV-3220	1
	0021	3570129B0	馬達整調板 ADJUSTABLE PLATE	3170\SS41	1
	0030	3971041A0	齒型皮帶輪(8YU/60T) PULLEY	3270\S45C	1
	0040	4600501200	齒型皮帶 PULLEY BELT	8YU-1200-50	1
	0051	4430412221	定積脫壓給油泵浦 LUBRICANT PUMP	MS-12W-220V單相-總高345	1
	0060	4510100001	油表 COOLANT LEVEL GAUGE	3''	1
	0071	3570130C0	油槽 OIL TROUGH	7520\SPCC	1
	0082	3570131C0	蓋板(油槽) OIL TROUGH COVER	7540\SPCC	1
	0090	4800408508	浮動開關含接桿 FLOATING SWITCH	M8-P=1.25/85L	1
	0110	3570135A0	銅管組 COPPER TUBING	4420\3/8銅管	1
	0120	3603203B0	管接頭 CONNECTOR	3240\SS41	1
	0130	4710021424	繼電器附燈 RELAY	MY-2NJ DC24V	2
	0140	4712081520	繼電器座 RELAY BRACKET	PYF-08A-E-T OMB	2
	0151	4710201901	電磁接觸器 ELECTROMAGNETIC CONTACTOR	DILM901D1	1
	0160	4721480633	歐式端子台 TERMINAL BLOCK	280-633	2
	0170	4721880314	端子台側板 SIDE PLATE, TERMINAL BLOCK	WAGO 280-314	1
	0180	4722349117	終端檔塊 STOPPER	WAGO 249-117	2
	0190	4710800106	線路保護器 LINE PROTECTION	FAZNS1P6A	1
	0200	4710315024	電源供應器 POWER SUPPLY	S150-24V(6.5A)	1
	0210	4510120001	塑膠油杯 OIL-TANK		1

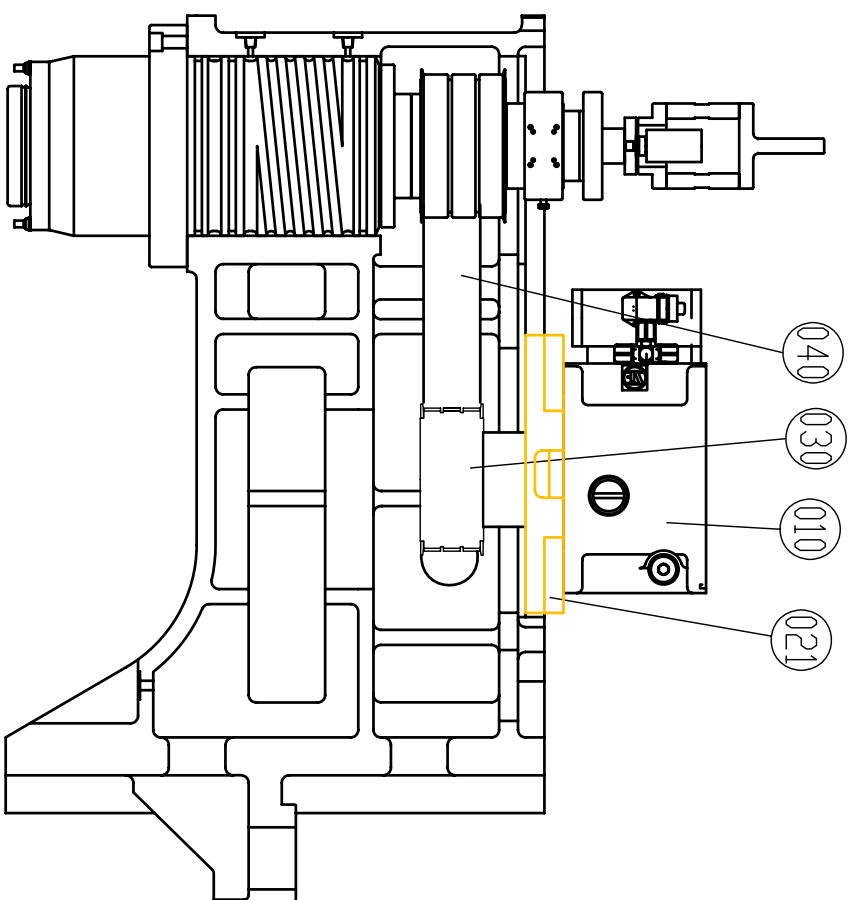
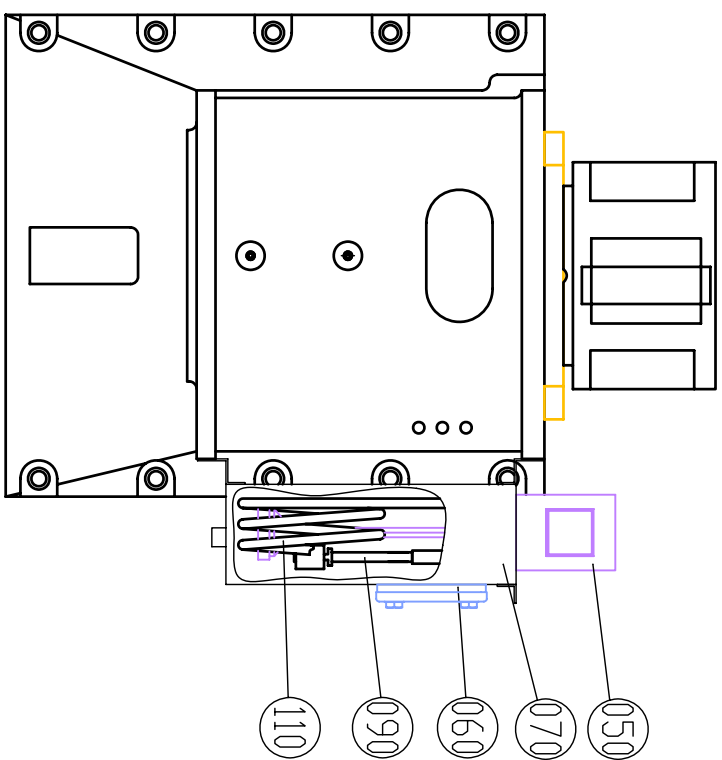
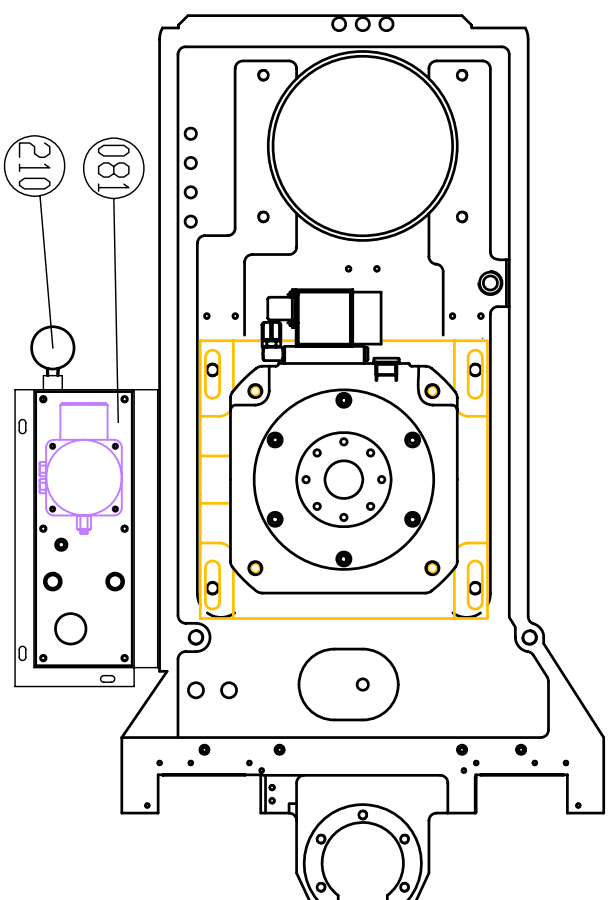

MV-1100D\MV-1300D

Leaderway Machinery Co. Ltd.

Scale 1:8		Drawing Name 主軸皮帶輪單元(GEAR BOX 2K121) SPINDLE BELT UNIT		Page 1/1	A3
Drawn Control	Name 洪文昇	Date 97.06.02	Draw No. 8120301B0 (2F28016)		

台灣力得衛宇龍科技股份有限公司

*單階材料用量清單

製表日期: 99-08-17

第1頁

主件品號	序號	元件品號	品名 英文品名	規 格	月量
2F28025			主軸皮帶輪單元(G-B) SPINDLE BELT UNIT	MV1100D/1300D+Gear Box(2K25C	
	0011	4430412221	定積脫壓給油泵浦 LUBRICANT PUMP	MS-12W-220V單相-總高345	1
	0020	4510100001	油表 COOLANT LEVEL GAUGE	3''	1
	0031	3570130C0	油槽 OIL TROUGH	7520\SPCC	1
	0041	3570131C0	蓋板(油槽) OIL TROUGH COVER	7540\SPCC	1
	0050	4800408508	浮動開關含接桿 FLOATING SWITCH	M8-P=1.25/85L	1
	0070	3570135A0	銅管組 COPPER TUBING	4420\3/8銅管	1
	0080	3603203B0	管接頭 CONNECTOR	3240\SS41	1
	0090	4710021424	繼電器附燈 RELAY	MY-2NJ DC24V	2
	0100	4712081520	繼電器座 RELAY BRACKET	PYF-08A-E-T OMB	2
	0111	4710201901	電磁接觸器 ELECTROMAGNETIC CONTACTOR	DILM901D1	1
	0120	4721480633	歐式端子台 TERMINAL BLOCK	280-633	2
	0130	4721880314	端子台側板 SIDE PLATE,TERMINAL BLOCK	WAGO 280-314	1
	0140	4722349117	終端檔塊 STOPPER	WAGO 249-117	2
	0150	4710800106	線路保護器 LINE PROTECTION	FAZNS1P6A	1
	0160	4710315024	電源供應器 POWER SUPPLY	S150-24V(6.5A)	1
	0170	3980090A0	ZF齒輪箱組件(2K250) GEAR BOX UNIT	9270\適用H.D.H QAN 260M馬達	1
	0180	3570154A0	馬達調整板 ADJUSTABLE PLATE	3170\SS41	1
	0190	3560583A0	墊塊 PAD	3180\SS41	4
	0200	3971049A0	齒型皮帶輪(8YU-72T) PULLEY	3270\S45C	1
	0210	4600230122	齒型皮帶 PULLEY BELT	8YU-1224-60	1
	0220	4510120001	塑膠油杯 OIL-TANK		1

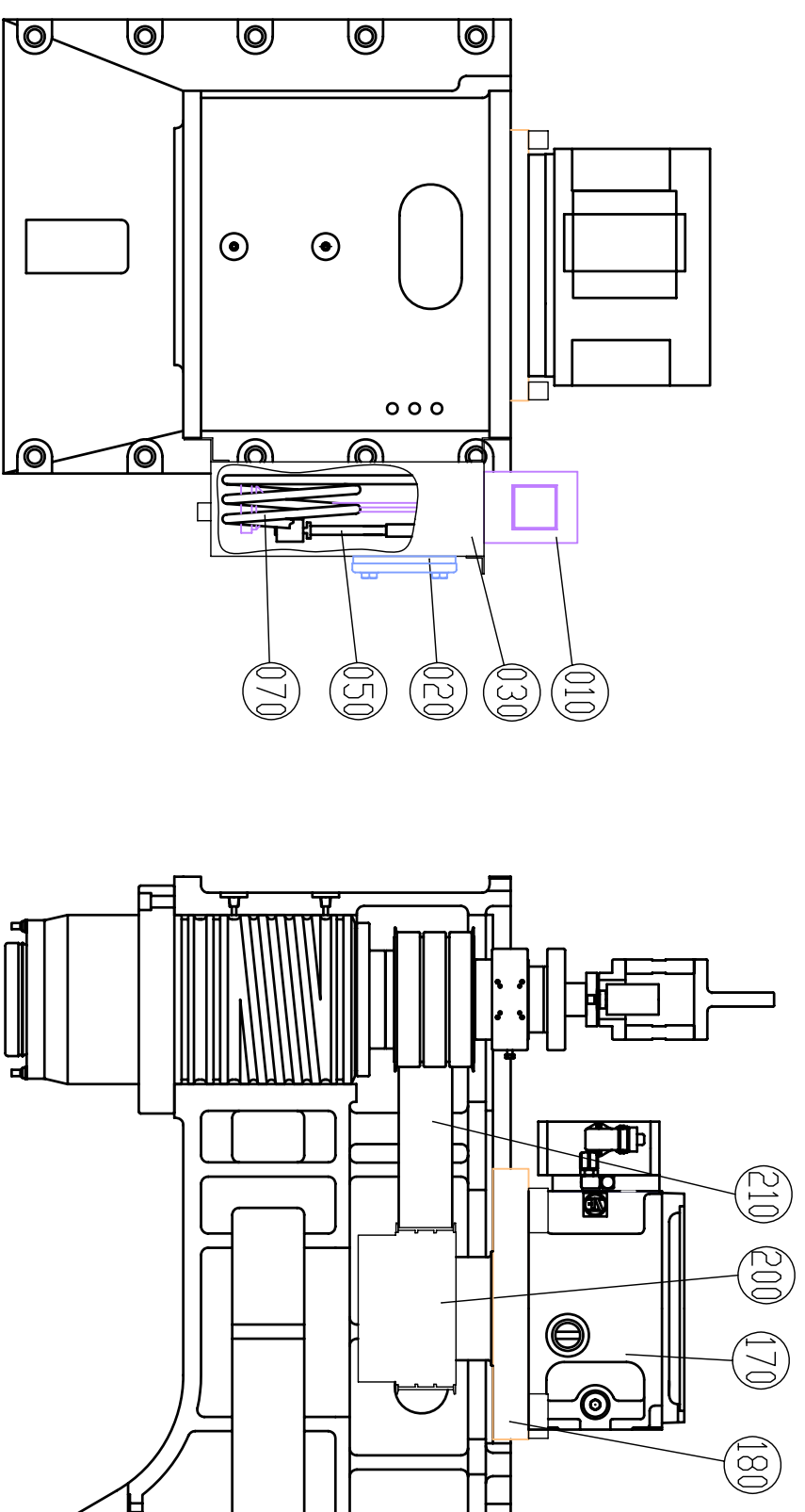
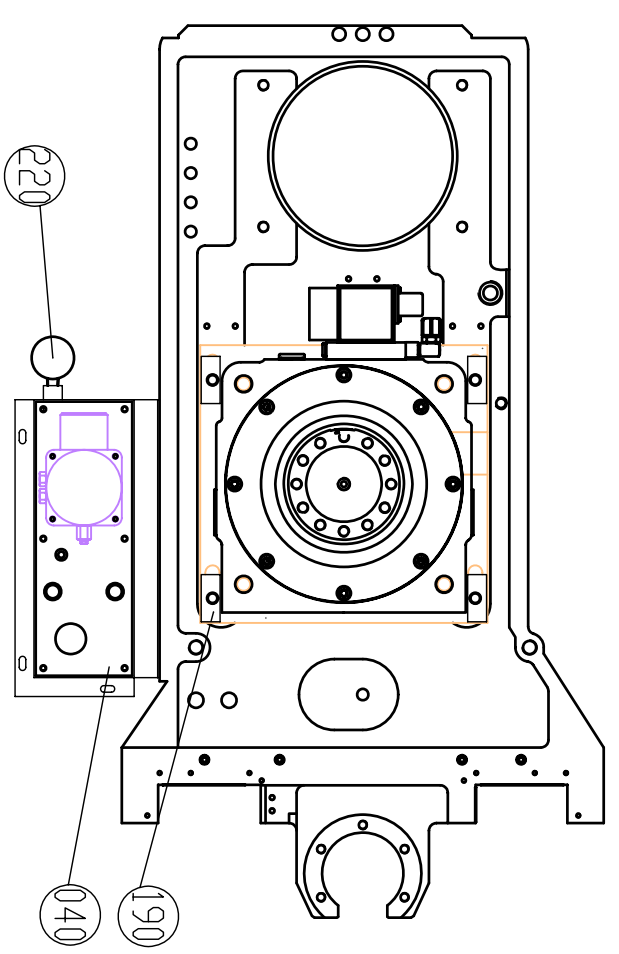

MV-1100D\MV-1300D

Leaderway Machinery Co. Ltd.

Scale 1:8		Drawing Name 主軸皮帶輪單元(GEAR BOX 2K250) SPINDLE BELT UNIT		Date 97.06.02		Page 1/1	
Drawn 洪文昇		Name Control		Date 97.06.02		Draw No. 8120346A0 (2F28025)	
Control		Control		Control		Control	

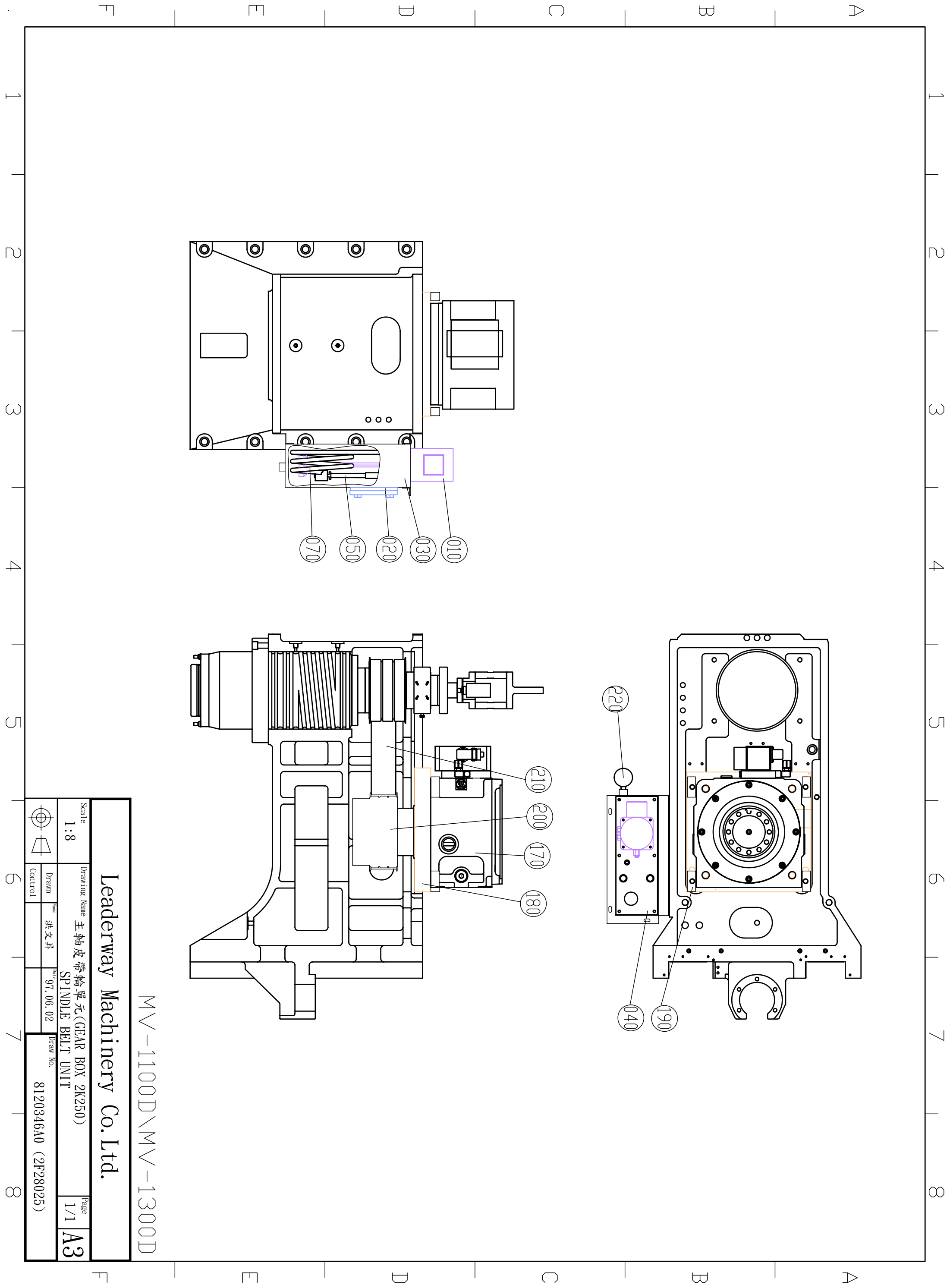

台灣力得衛宇龍科技股份有限公司

*單階材料用量清單

製表日期: 99-08-17

第1頁

主件品號	序號	元件品號	品名 英文品名	規 格	月量
2F28030			主軸皮帶輪單元 SPINDLE BELT UNIT	MV1100D/1300D/8YU-60T	
	0010	3971054A0	齒型皮帶輪(8YU-60T) PULLEY	3270\S45C	1
	0020	4600231184	齒型皮帶 PULLEY BELT	8YU-1184-50	1
	0030	3560318B0	主軸馬達調整板 ADJUSTABLE PLATE	3170\SS41	1
	0040	3600135A0	軸壓蓋(\$ 48) SHAFT END COVER	3240\S45C	1
	0050	4061248055	迫緊環 PACKING RING	TLK300 48x55	3
	0060	3600137A0	隔環(\$ 48) SPACER	3230\S45C	2

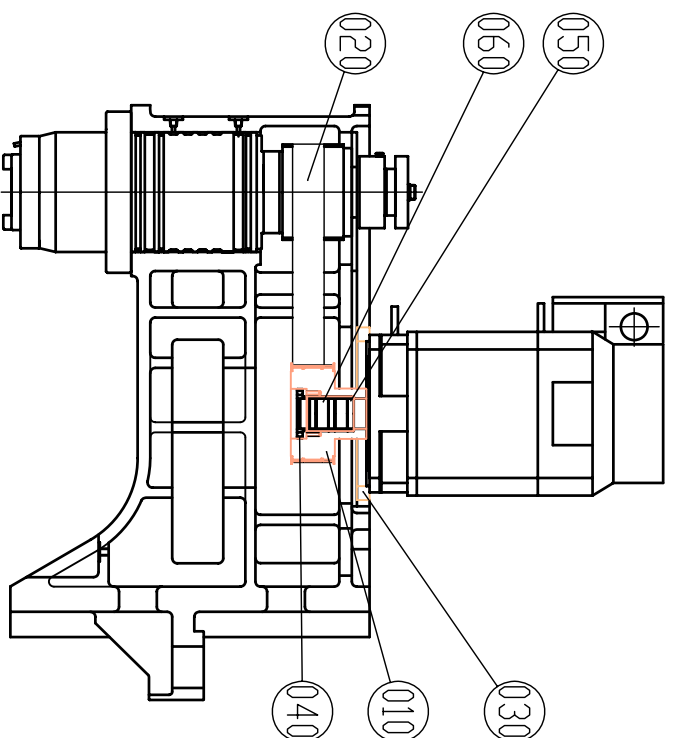
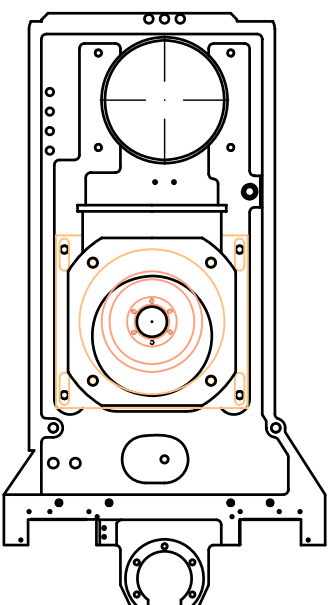

MV-1100D\MV-1300D

Leaderway Machinery Co. Ltd.

Scale		Drawing Name		Page	
1:12		主軸皮帶輪單元 SPINDLE BELT UNIT		1/1	
Drawn		Date		Draw No.	
Name		yy. mm. dd		8120392A0 (2F28030)	
Control		yy. mm. dd			
徐維駿		97. 06. 03			
審核					



台灣力得衛宇龍科技股份有限公司

*單階材料用量清單

製表日期: 97-06-13

第1頁

主件品號	序號	元件品號	品名 英文品名	規 格	用 量
2F50001			外型護罩單元 ENCLOSURE GUARD UNIT	V1100/MV1100S	
	0010	3520130A0	前門下門輪座 LOWER DOOR WHEEL BRACKET	7110\SPCC	4
	0020	3540068A0	右下連桿B支架 LOWER CONNECTING ROD BRACKET(R)	7210\SPCC	2
	0030	3540069A0	右前下連接板 FRONT CONNECTING PLATE(R)	7210\SPCC	2
	0040	3540111A0	飾板固定座 PLATE BRACKET	7210\SPCC	5
	0051	3560136C0	右門 RIGHT DOOR	7480\SPCC	1
	0061	3560141C0	左門 LEFT DOOR	7480\SPCC	1
	0070	3560142B0	上門軌 UPPER DOOR GUIDE	7130\SPCC	1
	0080	3560146B0	前門壓克力 ACRYLIC PLATE, FRONT DOOR	4360\ACRY	2
	0090	3560147B0	下門軌 LOWER DOOR GUIDE	3130\平鐵	1
	0100	3560148B0	前門側擋板 FRONT DOOR PLATE	7210\SPCC	2
	0110	3560149A0	上門輪座 DOOR WHEEL BRACKET	7110\SPCC	2
	0120	3560150B0	護罩支架	7210\SPCC	4
	0130	3560163B0	右蓄屑盤 CHIP PLATE (R)	7520\SPCC	1
	0140	3560164C0	左蓄屑盤 CHIP PLATE (L)	7520\SPCC	1
	0150	3560168B0	前門上檔板 UPPER COVER, FRONT DOOR	7210\SPCC	2
	0160	3560169B0	壓克力壓板 LOCKING PLATE, DOOR ACRYLIC PLATE	7120\SPCC	2
	0170	3560233A0	前飾板	7510\SPCC	1
	0180	3560234A0	右下飾板 (R) LOWER PLATE	7510\SPCC	1
	0190	3560246A0	左下連桿 (L) LOWER CONNECTING ROD	7210\SPCC	2
	0202	3560271E0	右護罩 RIGHT COVER	7500\SPCC	1
	0210	3560291B0	右上蓋板 RINGHT SIDE COVER	7510\SPCC	1
	0232	3560401E0	左護罩 LEFT COVER	7500\SPCC	1
	0242	3520054C0	門輪 DOOR WHEEL	3260\S45C	4
	0250	3520055A0	門輪 DOOR WHEEL	3260\S45C	4
	0263	3560273D0	護罩壓克力 SIDE DOOR ACRYLIC PLATE	4360\ACRY	2
	0270	3560443A0	左蓄屑盤側蓋 SIDE COVER,CHIP PLATE (L)	7180\SPCC	1
	0280	4060600028	C型扣環(孔用) C TYPE RETAINER RING	R-28	4
	0290	4060700012	C型扣環(軸用) C TYPE RETAINER RING	S-12	4
	0300	4300400600	管型把手(自然色) HAHDLE	U1-600L	2
	0310	4300401421	把手(染黑) HAHDLE	A-42-A	4
	0320	4400206001	深槽滾珠軸承 BEARING	6001ZZ 12x28x8	4
	0330	4402000628	軸承 BEARING	628ZZ 8*24*8 日本	12
	0340	4720735024	長臂工作燈 WORKING LIGHT	HS35P	1
	0350	3500159A0	水槍風槍座 WATER GUN BRACKET	7210\SPCC	1
	0362	3560501C0	電磁閥座 VALVE BRACKET	7210\SPCC	1

<續下頁>

台灣力得衛宇龍科技股份有限公司

*單階材料用量清單

製表日期: 97-06-13

第2頁

主件品號	序號	元件品號	品名 英文品名	規 格	用量
2F50001	0373	3560503D0	左後護罩 (L) REAR COVER	7500\SPCC	1
	0380	3560385A0	蓄屑盤亞管 CHIP PLATE PIPE	4420\鐵管	1
	0400	4210361200	噴水管(Y TYPE) NOZZLE TUBE	1/2"轉接頭*Y型接頭*2-1/2"扁嘴	2
	0410	4210012015	噴水管 NOZZLE TUBE	1/2"轉接頭*軟管x15*1-1/4"扁嘴	2
	0420	3560300B0	護罩前飾條 RUBBER RIBBON, TELESCOPIC BARREL	4510\SUS 303	1
	0430	3560579A0	側門飾條 RUBBER RIBBON	4510\SUS303光面	2
	0441	3500414B0	側門把手座 SIDE DOOR HANDLE BRACKET	7180\SPCC	4
	0450	4090500403	鎖頭 LOCK	C-403(長型)七星小S	4

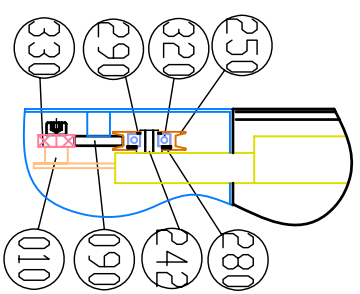

A試圖 1 : 5

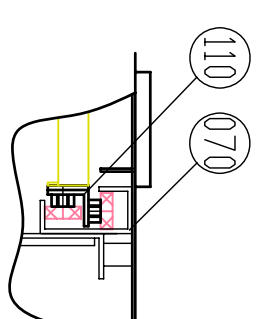
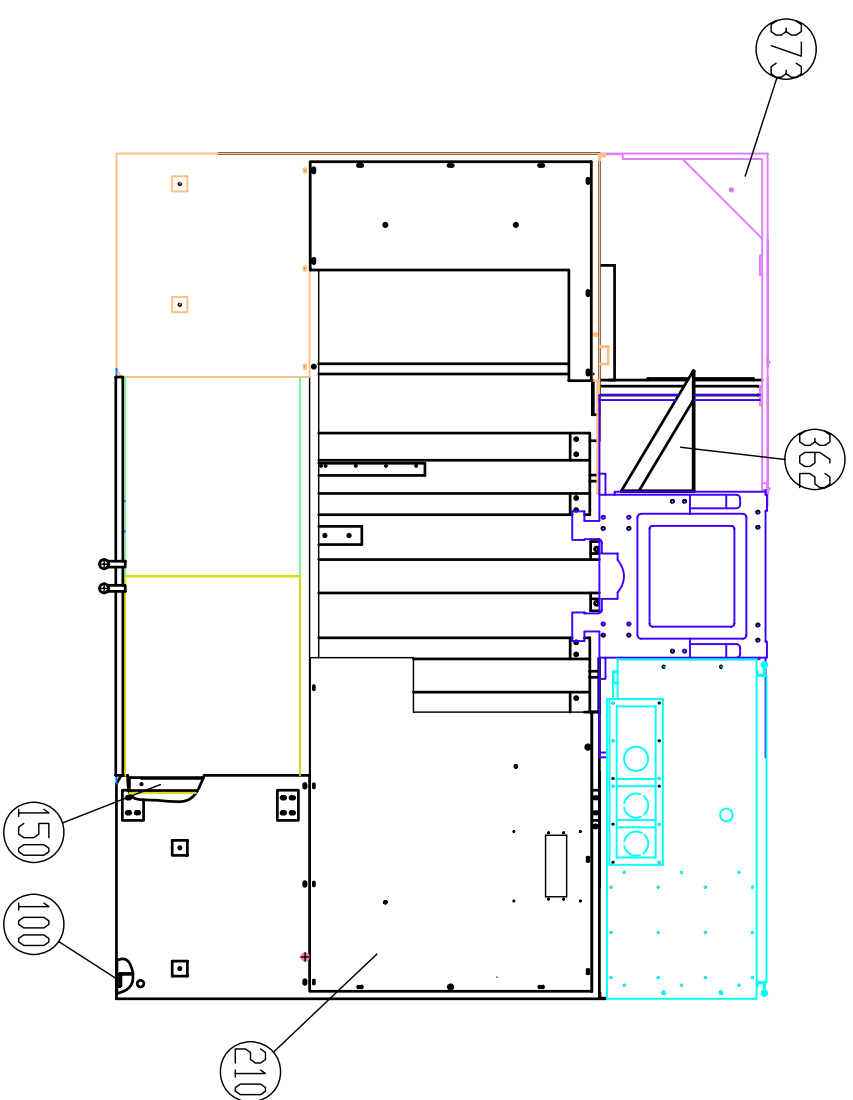

B試圖 1 : 5

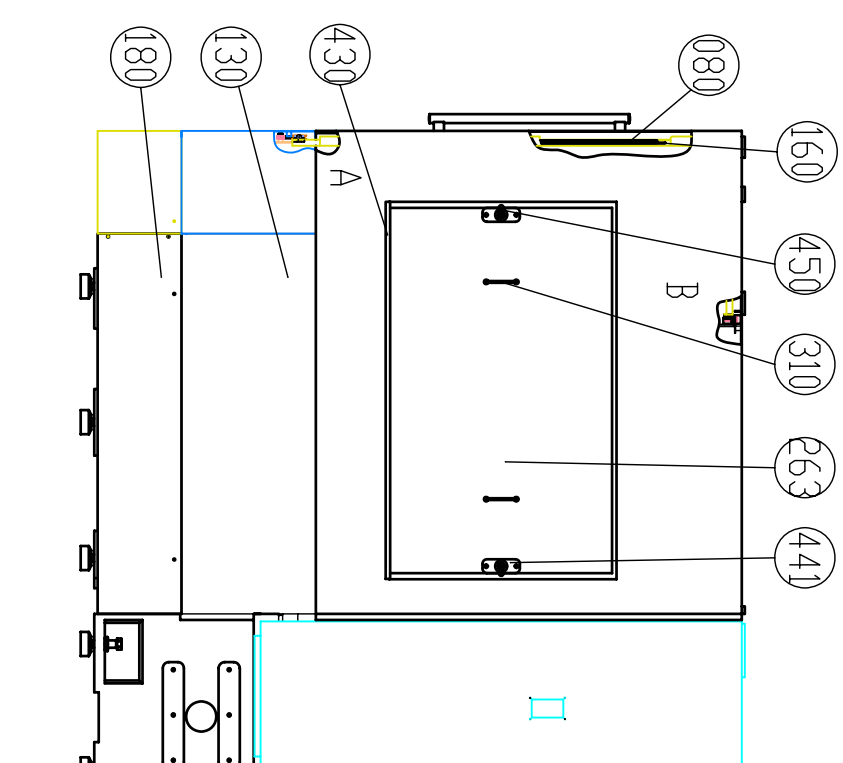
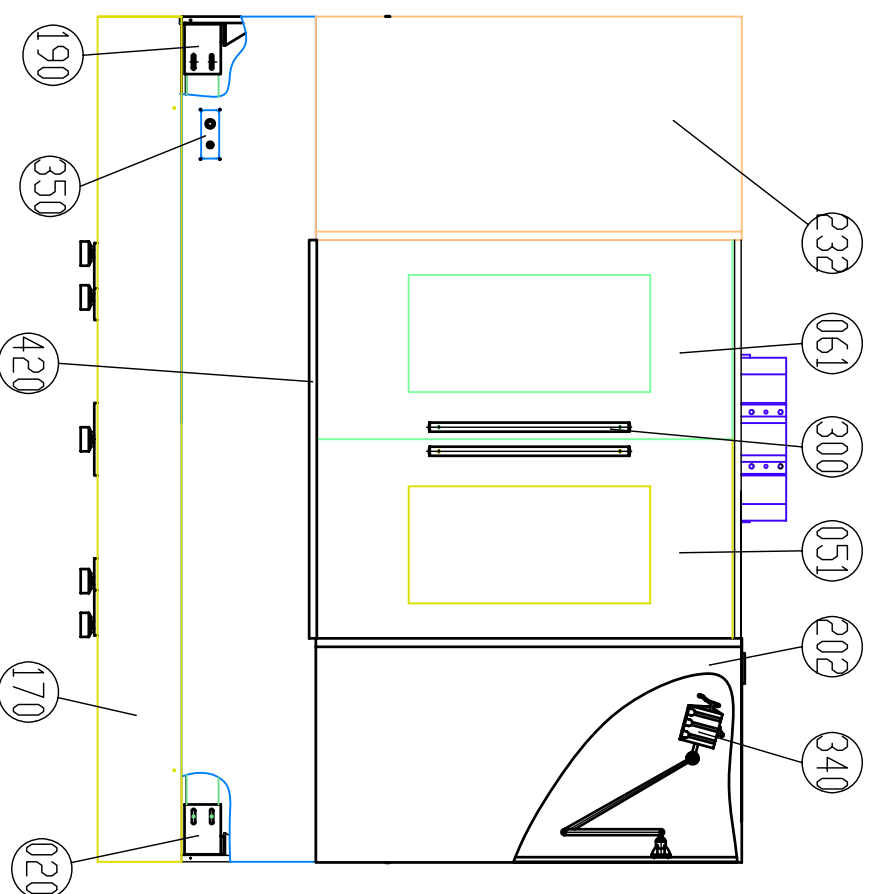
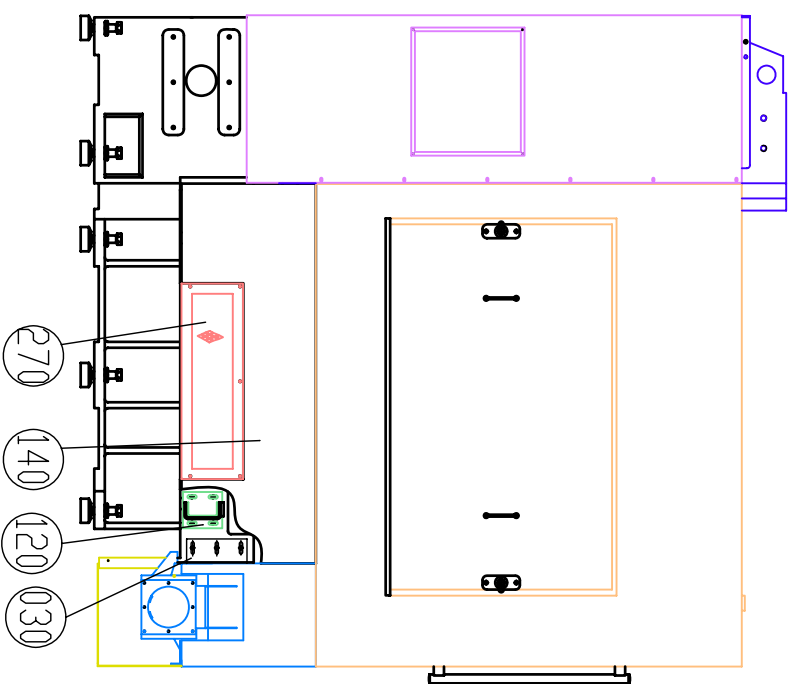

A B C D E F

1 2 3 4 5 6 7 8

A B C D E F

Leaderway Machinery Co. Ltd.

Scale		Drawing Name		Page	
1:25		V-1100\MV-1100S外型護罩單元		1/1	
Drawn		Date		Draw No.	
Control		97.06.06		8120114B0 (2F50001)	
		洪文昇			
		V-1100\MV-1100S COVER UNIT			

A3

台灣力得衛宇龍科技股份有限公司

*單階材料用量清單

製表日期: 97-06-19

第1頁

主件品號	序號	元件品號	品名 英文品名	規 格	用量
2F50003			外型護罩單元 ENCLOSURE GUARD UNIT	MV1100D	
	0010	3520130A0	前門下門輪座 LOWER DOOR WHEEL BRACKET	7110\SPCC	4
	0020	3540068A0	右下連桿B支架 LOWER CONNECTING ROD BRACKET(R)	7210\SPCC	2
	0030	3540069A0	右前下連接板 FRONT CONNECTING PLATE(R)	7210\SPCC	2
	0040	3540111A0	飾板固定座 PLATE BRACKET	7210\SPCC	5
	0050	3560146B0	前門壓克力 ACRYLIC PLATE, FRONT DOOR	4360\ACRY	2
	0060	3560147B0	下門軌 LOWER DOOR GUIDE	3130\平鐵	1
	0070	3560150B0	護罩支架 ENCLOSURE BRACKET	7210\SPCC	4
	0080	3560163B0	右蓄屑盤 CHIP PLATE (R)	7520\SPCC	1
	0090	3560164C0	左蓄屑盤 CHIP PLATE (L)	7520\SPCC	1
	0100	3560169B0	壓克力壓板 LOCKING PLATE, DOOR ACRYLIC PLATE	7120\SPCC	2
	0110	3560233A0	前飾板 FRONT PLATE	7510\SPCC	1
	0120	3560234A0	右下飾板 (R) LOWER PLATE	7510\SPCC	1
	0130	3560246A0	左下連桿 (L)LOWER CONNECTING ROD	7210\SPCC	2
	0162	3520054C0	門輪 DOOR WHEEL	3260\SA45C	4
	0170	3520055A0	門輪 DOOR WHEEL	3260\SA45C	4
	0183	3560273D0	護罩壓克力 SIDE DOOR ACRYLIC PLATE	4360\ACRY	2
	0190	3560443A0	左蓄屑盤側蓋 SIDE COVER,CHIP PLATE (L)	7180\SPCC	1
	0200	4060600028	C型扣環(孔用) C TYPE RETAINER RING	R-28	4
	0210	4060700012	C型扣環(軸用) C TYPE RETAINER RING	S-12	4
	0220	4300400600	管型把手(自然色) HAHDLE	U1-600L	2
	0230	4300401421	把手(染黑) HAHDLE	A-42-A	4
	0240	4400206001	深槽滾珠軸承 BEARING	6001ZZ 12x28x8	4
	0250	4402000628	軸承 BEARING	628ZZ 8*24*8 日本	16
	0260	4720735024	長臂工作燈 WORKING LIGHT	HS35P	1
	0270	3500159A0	水槍風槍座 WATER GUN BRACKET	7210\SPCC	1
	0293	3560501C0	電磁閥座 VALVE BRACKET	7210\SPCC	1
	0304	3560466F0	左護罩 LEFT COVER	7500\SPCC	1
	0313	3560467E0	右護罩 RIGHT COVER	7500\SPCC	1
	0320	3560469A0	上門軌 UPPER DOOR GUIDE	3130\SS41	2
	0331	3560470B0	右上蓋板(二) RINGHT SIDE COVER(2)	7510\SPCC	1
	0341	3560471B0	左門 LEFT DOOR	7480\SPCC	1
	0351	3560472B0	右門 RIGHT DOOR	7480\SPCC	1
	0360	3560482A0	右上蓋板(一) RINGHT SIDE COVER(1)	7510\SPCC	1
	0370	3570114A0	前門上檔板 UPPER COVER, FRONT DOOR	7210\SPCC	2
	0380	3570116A0	上門輪座 DOOR WHEEL BRACKET	7110\SPCC	6

<續下頁>

台灣力得衛宇龍科技股份有限公司

*單階材料用量清單

製表日期: 97-06-19

第2頁

主件品號	序號	元件品號	品名 英文品名	規 格	用量
2F50003	0390	4210012015	噴水管 NOZZLE TUBE	1/2"轉接頭*軟管x15*1-1/4"扁嘴	2
	0400	4210361200	噴水管(Y TYPE) NOZZLE TUBE	1/2"轉接頭*Y型接頭*2-1/2"扁嘴	2
	0410	3560300B0	護罩前飾條 RUBBER RIBBON, TELESCOPIC BARREL	4510\SUS 303	1
	0420	3560385A0	蓄屑盤亞管 CHIP PLATE PIPE	4420\鐵管	1
	0432	3560503E0	左後護罩 (L) REAR COVER	7500\SPCC	1
	0440	3560579A0	側門飾條 RUBBER RIBBON	4510\SUS303光面	2
	0451	3500414B0	側門把手座 SIDE DOOR HANDLE BRACKET	7180\SPCC	4
	0460	4090500403	鎖頭 LOCK	C-403(長型)七星小S	4
	0470	3560634A0	左右門出貨固定板 SHIPPING BRACKET	7200/3t SPCC	2

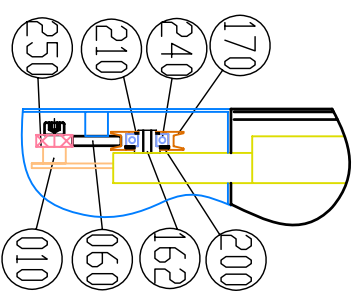

A視圖 1 : 5

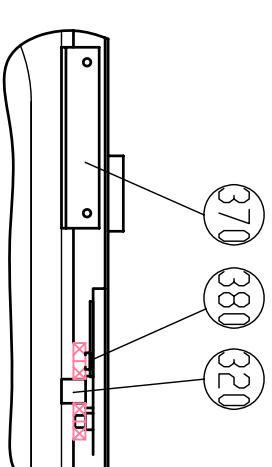
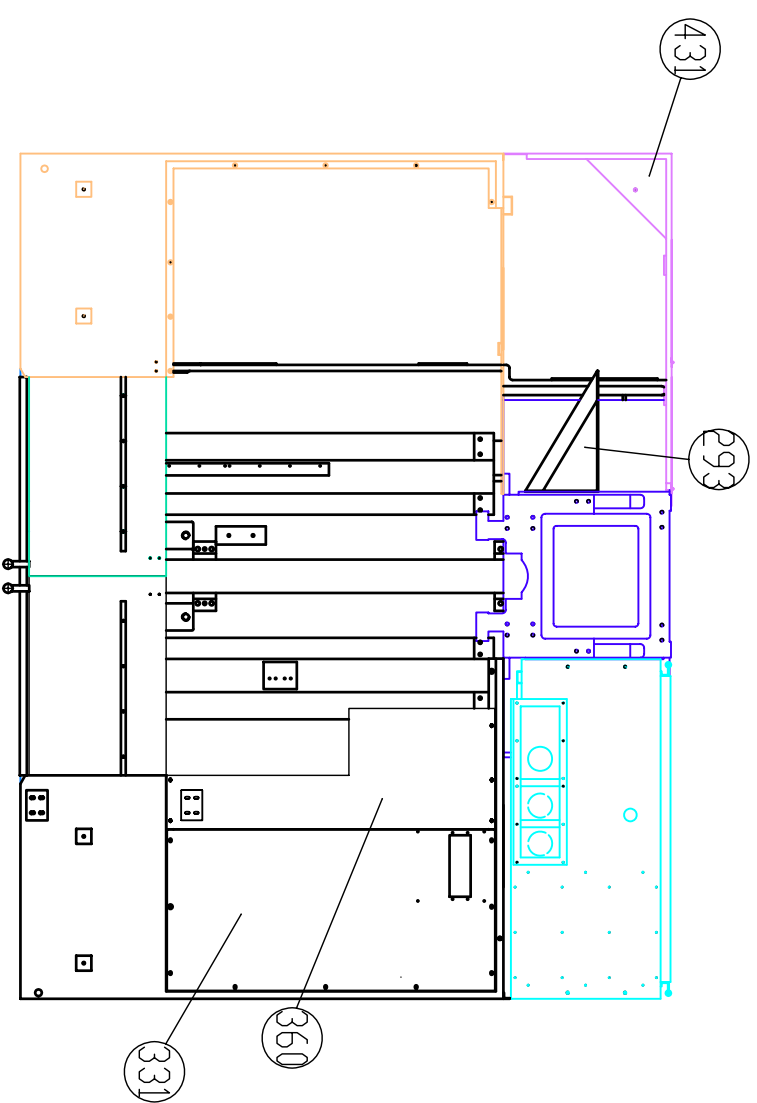

B視圖 1 : 5

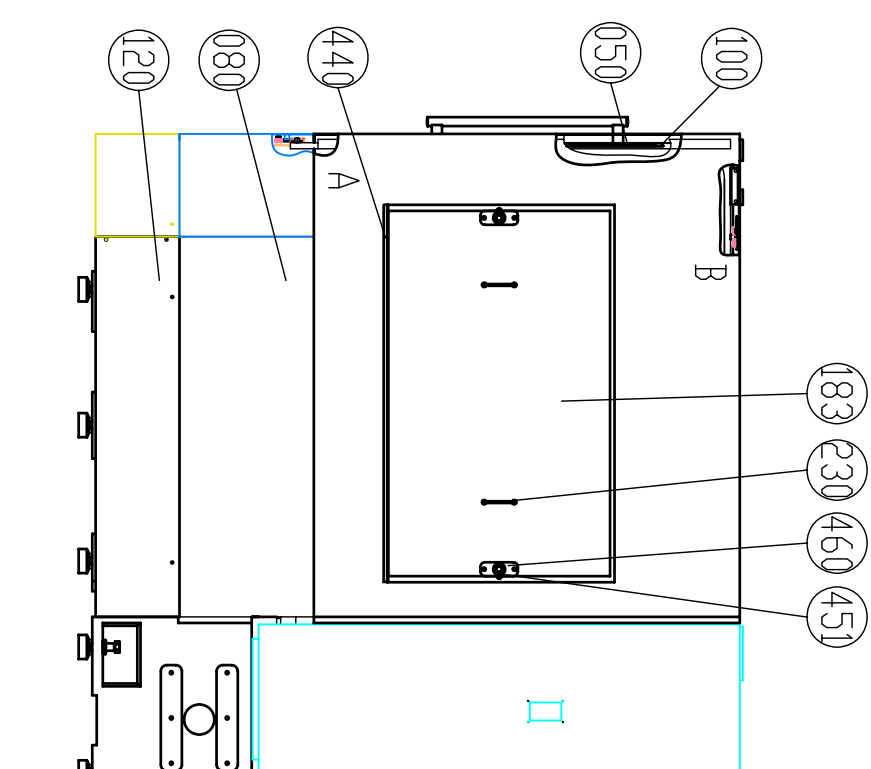
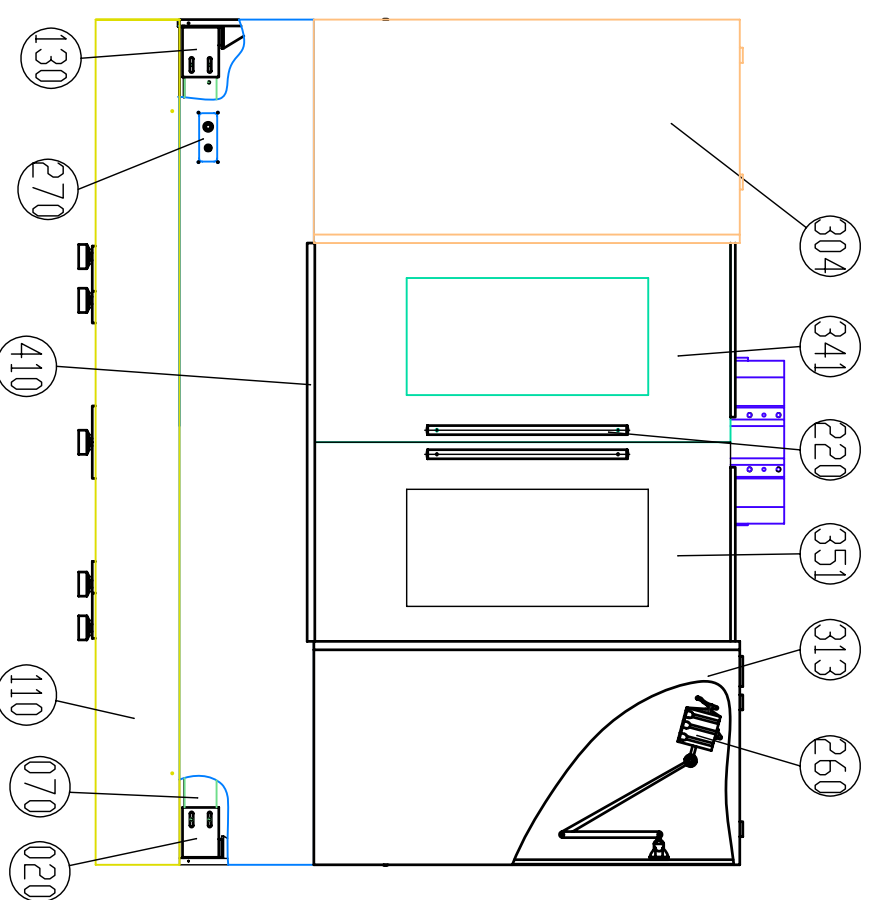
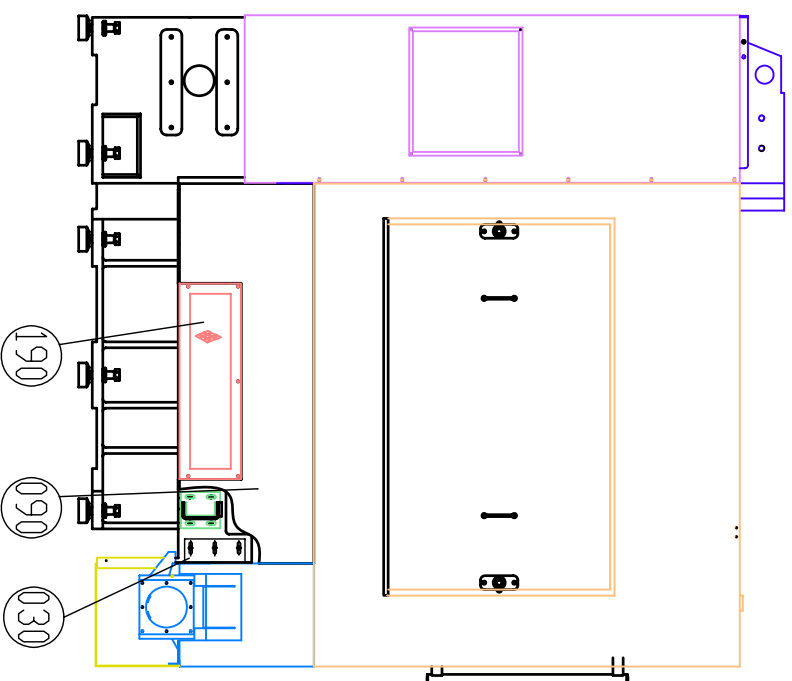

A B C D E F

1 2 3 4 5 6 7 8

F E D C B A

Leaderway Machinery Co. Ltd.

Scale		Drawing Name		Page	
1:25		MV-1100D外型護罩單元 MV-1100D COVER UNIT		1/1	
Drawn	洪文昇	Date	97.06.16	Draw No.	8120230B0 (2F50003)
Control					

A3

1 2 3 4 5 6 7 8

台灣力得衛宇龍科技股份有限公司

*單階材料用量清單

製表日期: 99-08-17

第1頁

主作品號	序號	元作品號	品名 英文品名	規 格	月量
2F50004			外型護罩單元 ENCLOSURE GUARD UNIT	MV-1300S	
	0010	3520130A0	前門下門輪座 LOWER DOOR WHEEL BRACKET	7110\SPCC	4
	0020	3540068A0	右下連桿B支架 LOWER CONNECTING ROD BRACKET	7210\SPCC	2
	0030	3540069A0	右前下連接板 FRONT CONNECTING PLATE(R)	7210\SPCC	2
	0050	3560148B0	前門側擋板 FRONT DOOR PLATE	7210\SPCC	2
	0060	3560168B0	前門上檔板 UPPER COVER, FRONT DOOR	7210\SPCC	2
	0081	3560239B0	分油座固定板 OIL DISTRIBUTOR BRACKET	7210\SPCC	1
	0090	3560246A0	左下連桿 (L)LOWER CONNECTING ROD	7210\SPCC	2
	0100	3560443A0	左蓄屑盤側蓋 SIDE COVER,CHIP PLATE (L)	7180\SPCC	1
	0111	3570074B0	右門 RIGHT DOOR	7480\SPCC	1
	0121	3570075B0	左門 LEFT DOOR	7480\SPCC	1
	0130	3570076A0	上門軌 UPPER DOOR GUIDE	7130\SPCC	1
	0140	3570077A0	前門壓克力 ACRYLIC PLATE, FRONT DOOR	4360\ACRY	2
	0150	3570078A0	下門軌 LOWER DOOR GUIDE	3130\平鐵	2
	0160	3570079A0	上門輪座 DOOR WHEEL BRACKET	7110\SPCC	2
	0171	3570080B0	護罩支架 ENCLOSURE BRACKET	7210\SPCC\MV1300S-D	4
	0180	3570082A0	右蓄屑盤 CHIP PLATE (R)	7520\SPCC	1
	0190	3570083B0	左蓄屑盤 CHIP PLATE (L)	7520\SPCC	1
	0200	3570084A0	前門壓克力壓板 LOCKING PLATE, DOOR ACRYLIC	7120\SPCC	2
	0213	3570085D0	右護罩 RIGHT GUARD	7500\SPCC	1
	0224	3570086E0	左護罩 LEFT GUARD	7500\SPCC	1
	0233	3570093E0	右上蓋板(二) RINGHT SIDE COVER(2)	7510\SPCC	1
	0241	3570094C0	右上蓋板(一) RINGHT SIDE COVER(1)	7510\SPCC	1
	0250	3570101A0	護罩前飾條 RUBBER RIBBON, TELESCOPIC BA	4510\SUS 303	1
	0262	3520054C0	門輪 DOOR WHEEL	3260\S45C	4
	0270	3520055A0	門輪 DOOR WHEEL	3260\S45C	4
	0283	3560273D0	護罩壓克力 SIDE DOOR ACRYLIC PLATE	4360\ACRY	2
	0290	4300400600	管型把手(自然色) HAHDLE	U1-600L	2
	0300	4300401421	把手(染黑) HAHDLE	A-42-A	4
	0310	4400206001	深槽滾珠軸承 BEARING	6001ZZ 12x28x8	4
	0320	4402000628	軸承 BEARING	628ZZ 8*24*8 日本	12

<續下頁>

台灣力得衛宇龍科技股份有限公司

*單階材料用量清單

製表日期: 99-08-17

第2頁

主作品號	序號	元作品號	品名 英文品名	規 格	數量
2F50004	0330	4720735024	長臂工作燈 WORKING LIGHT	HS35P	1
	0340	4060600028	C型扣環(孔用) C TYPE RETAINER RING	R-28	4
	0350	4060700012	C型扣環(軸用) C TYPE RETAINER RING	S-12	4
	0360	3560234A0	右下飾板 (R) LOWER PLATE	7510\SPCC	1
	0380	3570089A0	前飾板(一) FRONT PLATE(1)	7510\SPCC	1
	0390	3570090A0	前飾板(二) FRONT PLATE(2)	7510\SPCC	1
	0400	3540111A0	飾板固定座 PLATE BRACKET	7210\SPCC	10
	0413	3560501D0	電磁閥座 VALVE BRACKET	7210\SPCC\MV1100S-D	1
	0430	4210012015	噴水管 NOZZLE TUBE	1/2"轉接頭*軟管x15*1-1/4"扁	2
	0440	4210361200	噴水管(Y TYPE) NOZZLE TUBE	1/2"轉接頭*Y型接頭*2-1/2"扁	2
	0450	3500159A0	水槍風槍座 WATER GUN / AIR GUN SEAT	7210\SPCC	1
	0460	3560385A0	蓄屑盤亞管 CHIP PLATE PIPE	4420\鐵管	1
	0493	3570151D0	左後護罩 (L) REAR GUARD	7500\SPCC	1
	0500	3560579A0	側門飾條 RUBBER RIBBON	4510\SUS303光面	2
	0511	3500414B0	側門把手座 SIDE DOOR HANDLE BRACKET	7180\SPCC	4
	0520	4090500403	鎖頭 LOCK	C-403(長型)七星小S	4

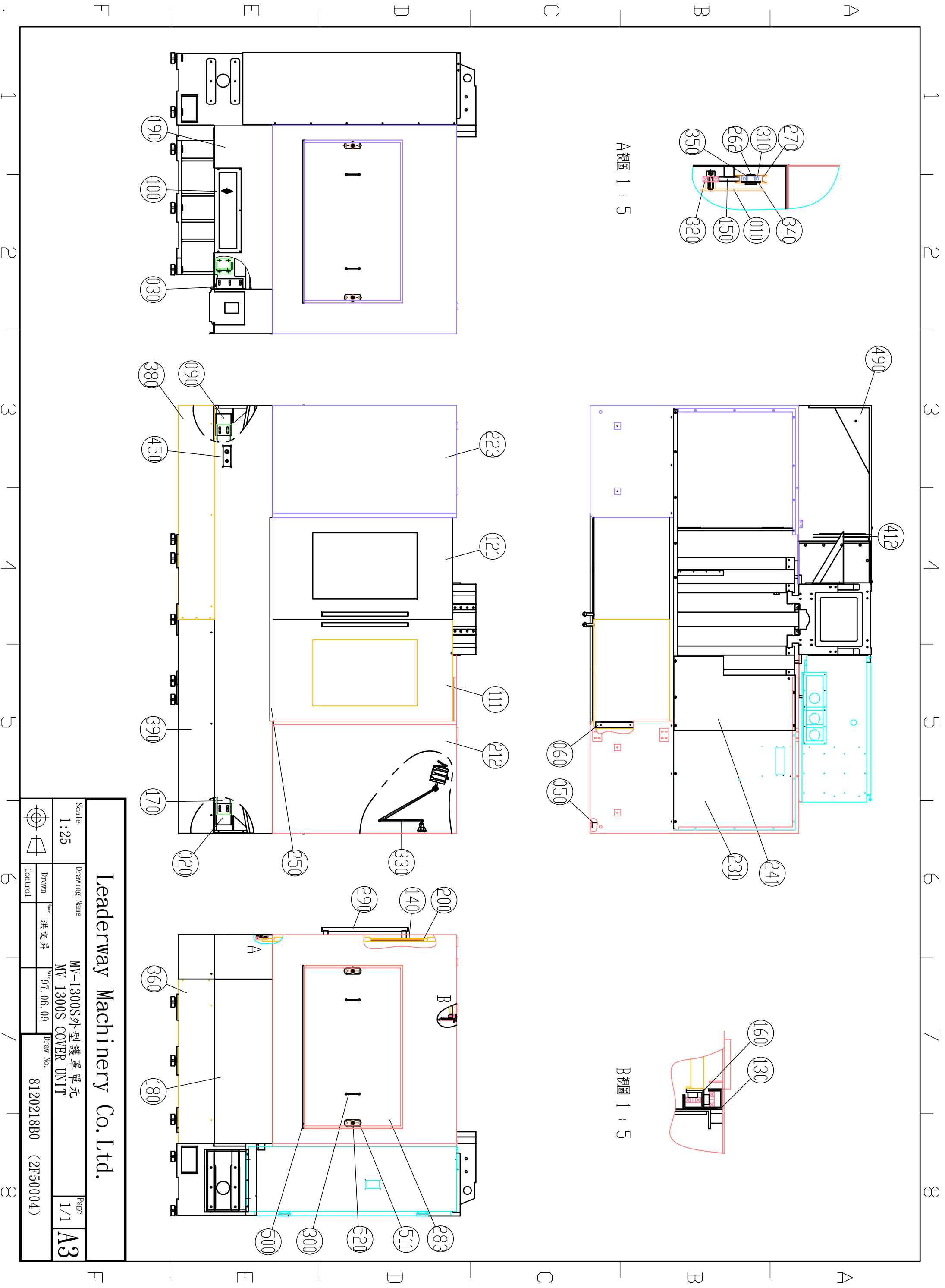

A視圖 1:5

B視圖 1:5

Leaderway Machinery Co. Ltd.

Scale 1:25		Drawing Name MV-1300S外型護罩單元 MV-1300S COVER UNIT		Page 1/1
Drawn Control	洪文昇	Date 97.06.09	Draw No. 8120218B0 (2F50004)	Page A3

台灣力得衛宇龍科技股份有限公司

*單階材料用量清單

製表日期: 99-08-17

第1頁

主作品號	序號	元作品號	品名 英文品名	規 格	用量
2F50005			外型護罩單元 ENCLOSURE GUARD UNIT	MV-1300D	
	0010	3520130A0	前門下門輪座 LOWER DOOR WHEEL BRACKET	7110\SPCC	4
	0020	3540068A0	右下連桿B支架 LOWER CONNECTING ROD BRACKET	7210\SPCC	2
	0030	3540069A0	右前下連接板 FRONT CONNECTING PLATE(R)	7210\SPCC	2
	0050	3570114A0	前門上檔板 UPPER COVER, FRONT DOOR	7210\SPCC	2
	0071	3560239B0	分油座固定板 OIL DISTRIBUTOR BRACKET	7210\SPCC	1
	0080	3560246A0	左下連桿 (L)LOWER CONNECTING ROD	7210\SPCC	2
	0090	3560443A0	左蓄屑盤側蓋 SIDE COVER,CHIP PLATE (L)	7180\SPCC	1
	0101	3570113B0	右門 RIGHT DOOR	7480\SPCC	1
	0111	3570112B0	左門 LEFT DOOR	7480\SPCC	1
	0121	3570115B0	上門軌 UPPER DOOR GUIDE	3130\SS41	2
	0130	3570077A0	前門壓克力 ACRYLIC PLATE, FRONT DOOR	4360\ACRY	2
	0140	3570078A0	下門軌 LOWER DOOR GUIDE	3130\平鐵	2
	0151	3570080B0	護罩支架 ENCLOSURE BRACKET	7210\SPCC\MV1300S-D	4
	0160	3570082A0	右蓄屑盤 CHIP PLATE (R)	7520\SPCC	1
	0170	3570083B0	左蓄屑盤 CHIP PLATE (L)	7520\SPCC	1
	0180	3570084A0	前門壓克力壓板 LOCKING PLATE, DOOR ACRYLIC	7120\SPCC	2
	0193	3570107E0	右護罩 RIGHT GUARD	7500\SPCC	1
	0204	3570106F0	左護罩 LEFT GUARD	7500\SPCC	1
	0212	3570110C0	右上蓋板(二) RINGHT SIDE COVER(2)	7510\SPCC	1
	0221	3570109B0	右上蓋板(一) RINGHT SIDE COVER(1)	7510\SPCC	1
	0230	3570101A0	護罩前飾條 RUBBER RIBBON, TELESCOPIC BA	4510\SUS 303	1
	0242	3520054C0	門輪 DOOR WHEEL	3260\S45C	4
	0250	3520055A0	門輪 DOOR WHEEL	3260\S45C	4
	0263	3560273D0	護罩壓克力 SIDE DOOR ACRYLIC PLATE	4360\ACRY	2
	0270	4300400600	管型把手(自然色) HAHDLE	U1-600L	2
	0280	4300401421	把手(染黑) HAHDLE	A-42-A	4
	0290	4400206001	深槽滾珠軸承 BEARING	6001ZZ 12x28x8	4
	0300	4402000628	軸承 BEARING	628ZZ 8*24*8 日本	16
	0310	4720735024	長臂工作燈 WORKING LIGHT	HS35P	1
	0320	4060600028	C型扣環(孔用) C TYPE RETAINER RING	R-28	4

<續下頁>

台灣力得衛宇龍科技股份有限公司

*單階材料用量清單

製表日期: 99-08-17

第2頁

主作品號	序號	元作品號	品名 英文品名	規 格	月量
2F50005	0330	4060700012	C型扣環(軸用) C TYPE RETAINER RING	S-12	4
	0340	3570116A0	上門輪座 DOOR WHEEL BRACKET	7110\SPCC	6
	0354	3560501D0	電磁閥座 VALVE BRACKET	7210\SPCC\MV1100S-D	1
	0370	3560234A0	右下飾板 (R) LOWER PLATE	7510\SPCC	1
	0390	3570089A0	前飾板(一) FRONT PLATE(1)	7510\SPCC	1
	0400	3570090A0	前飾板(二) FRONT PLATE(2)	7510\SPCC	1
	0410	3540111A0	飾板固定座 PLATE BRACKET	7210\SPCC	10
	0420	3560481A0	前門出貨固定架 SHIPPING BRACKET	7210\SPCC	2
	0430	4210361200	噴水管(Y TYPE) NOZZLE TUBE	1/2"轉接頭*Y型接頭*2-1/2"扁	2
	0440	4210012015	噴水管 NOZZLE TUBE	1/2"轉接頭*軟管x15*1-1/4"扁	2
	0450	3500159A0	水槍風槍座 WATER GUN / AIR GUN SEAT	7210\SPCC	1
	0460	3560385A0	蓄屑盤亞管 CHIP PLATE PIPE	4420\鐵管	1
	0493	3570151D0	左後護罩 (L) REAR GUARD	7500\SPCC	1
	0500	3560579A0	側門飾條 RUBBER RIBBON	4510\SUS303光面	2
	0511	3500414B0	側門把手座 SIDE DOOR HANDLE BRACKET	7180\SPCC	4
	0520	4090500403	鎖頭 LOCK	C-403(長型)七星小S	4
	0530	3560634A0	左右門出貨固定板 SHIPPING BRACKET	7200\SPCC	2

scale 1 : 5

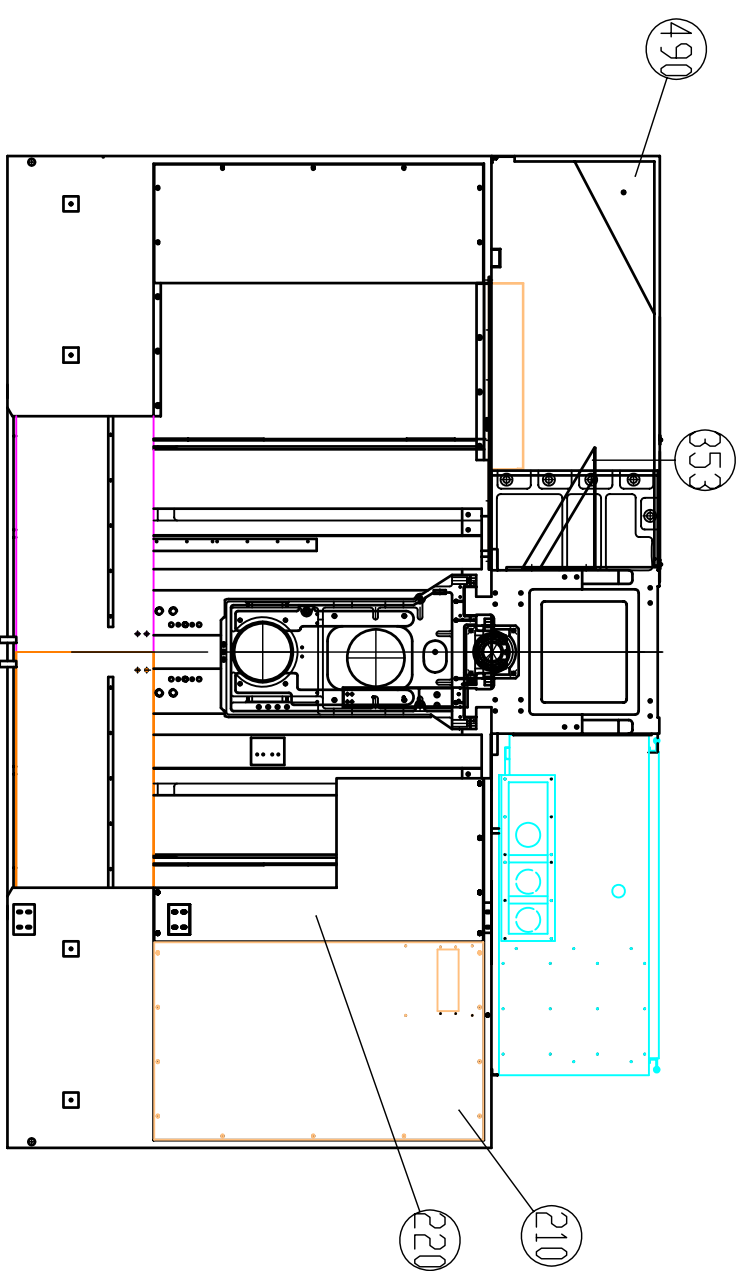
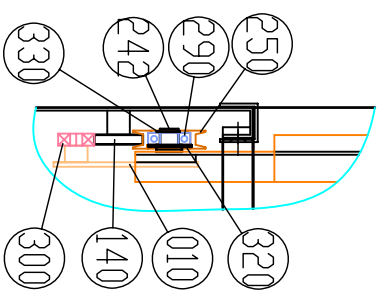

scale 1 : 5

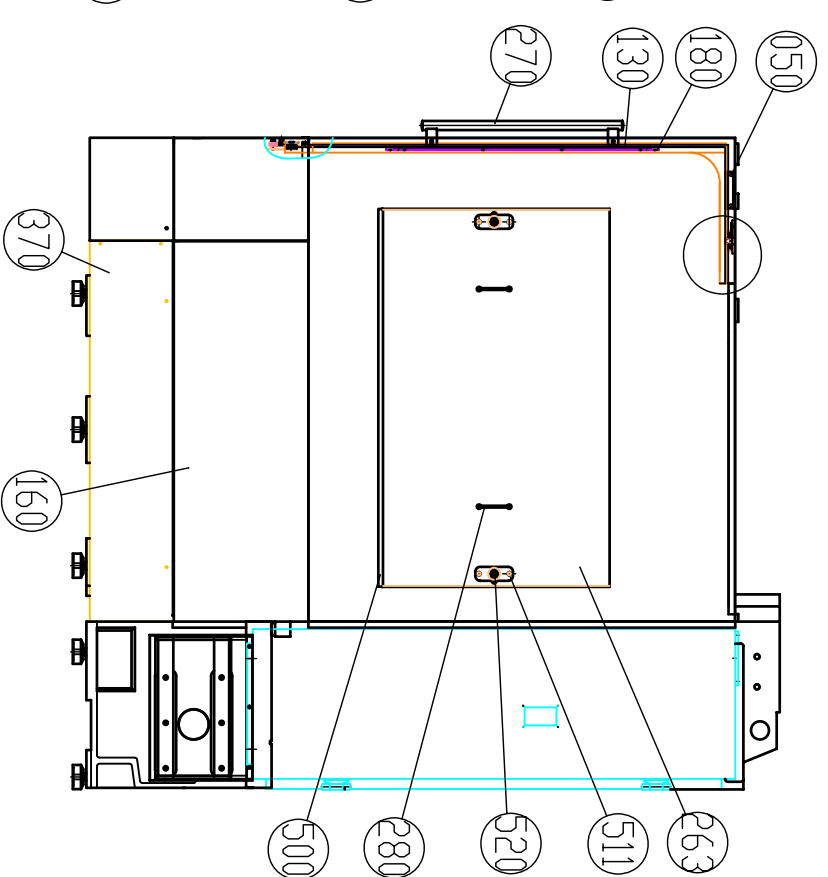
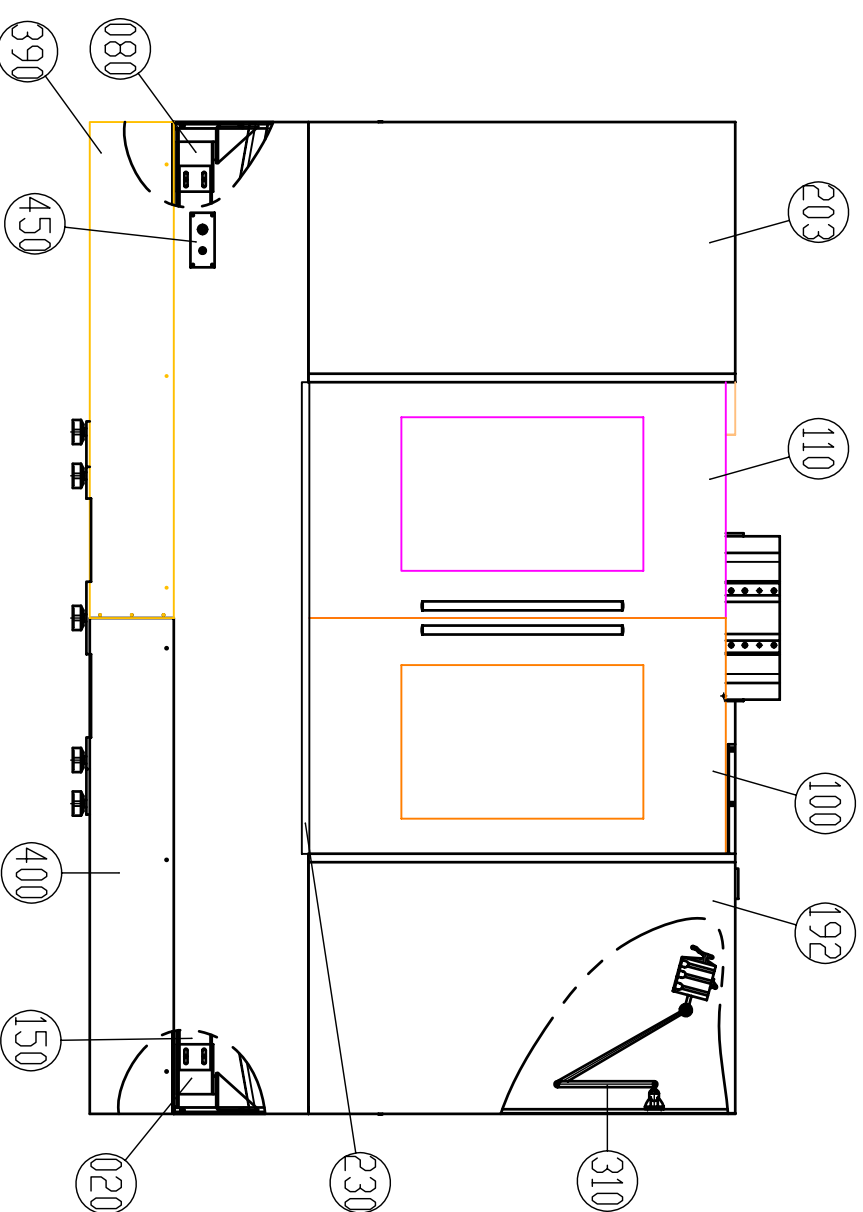
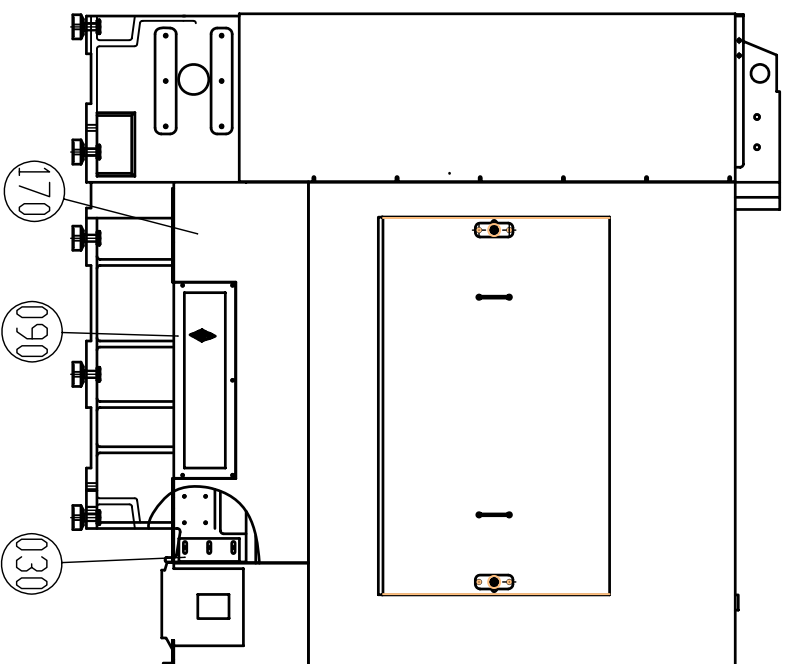
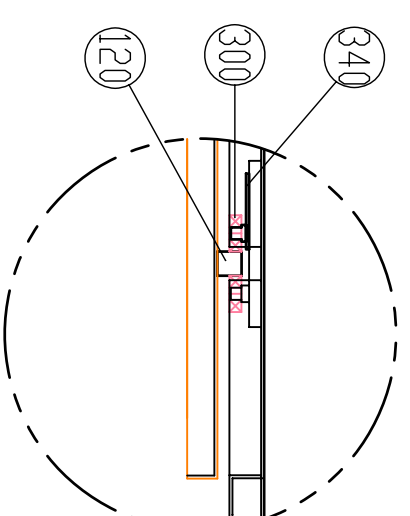

Leaderway Machinery Co. Ltd.

Scale	1 : 25		Drawing Name	MV-1300D外型護罩單元(MV-1300D COVER UNIT)		Page	1/1
Drawn	徐維駿	Date	97.05.27	Draw No.	8120388A0 (2F50005)	A3	
Control	審核	Drawn	yy.mm.dd				

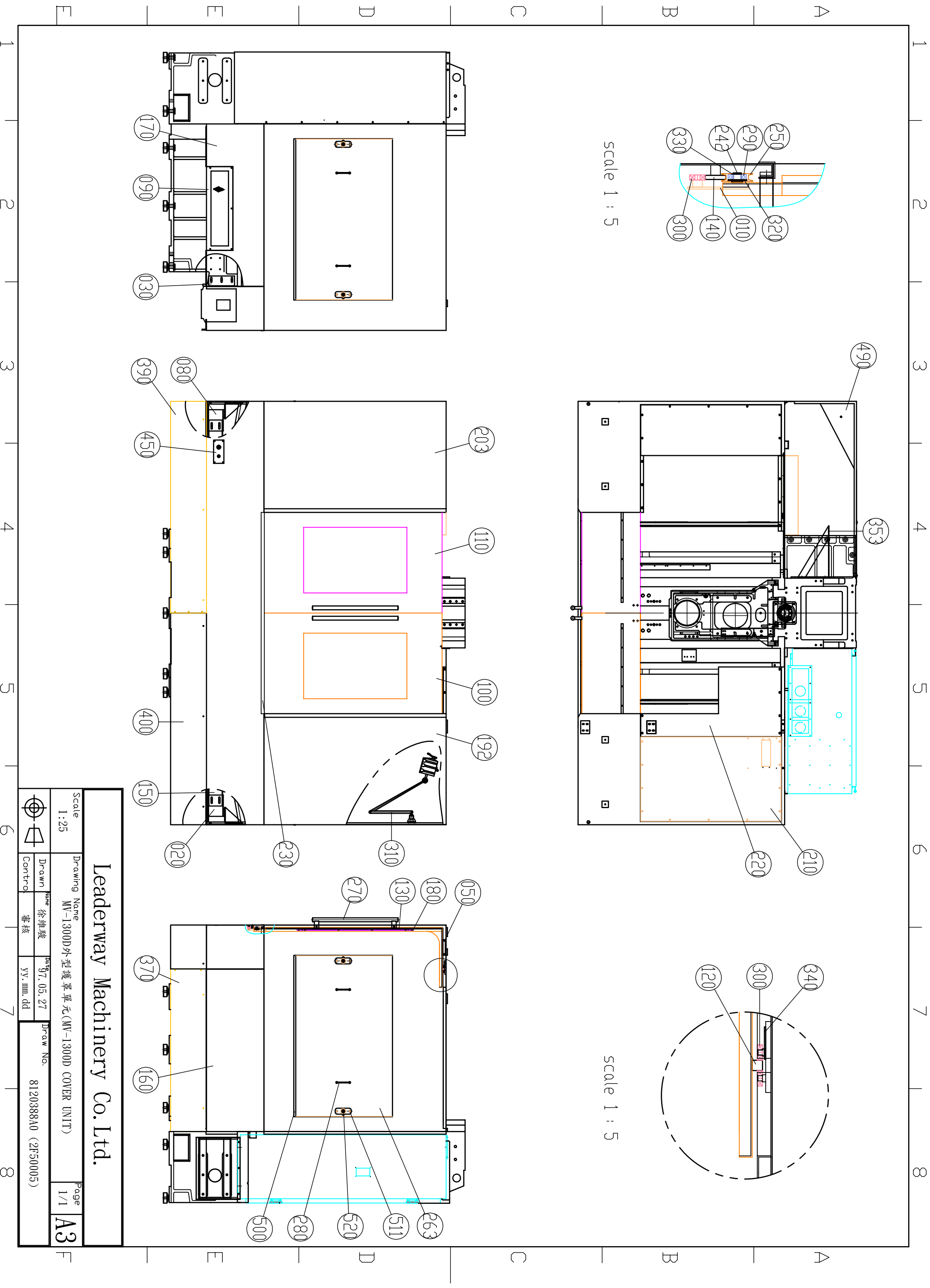

台灣力得衛宇龍科技股份有限公司

*單階材料用量清單

製表日期: 97-06-13

第1頁

主件品號	序號	元件品號	品名 英文品名	規 格	目量
2F51001			水箱單元(含螺旋排屑) COOLANT UNIT(COIL TYPE CONVEYOR)	V1100/MV1100S-D	
	0014	3560427D0	前下護罩 FRONT LOWER TELESCOPIC BARREL	7500\SPCC	1
	0025	3560428A0	水箱 COOLANT TANK	7580\SPCC	1
	0033	3560429C0	水箱蓋 COOLANT TANK COVER	7510\SPCC	1
	0043	3560430B0	水箱蓋 COOLANT TANK COVER	7510\SPCC	1
	0052	3560192B0	過濾網 FILTER NET	7590\SPCC	2
	0065	3560431A0	泵浦固定板 PUMP BRACKET	7180\SPCC	1
	0070	3560433B0	排屑炮管(附蓋及防漏膠墊) CHIP THROUGH TUBE	7570\SPCC	1
	0080	3560434B0	捲屑器 CHIP CONVEYOR	4570\市購品	1
	0091	3560249B0	偵測器孔蓋 HOLE COVER	7180\SPCC	1
	0100	4440800016	排屑器馬達 CONVEYOR MOTOR	1/2HP 1:100 FME28	1
	0120	4430040303	切削液泵浦(直立式) COOLANT PUMP	TPHK4T3-2S	2
	0130	4510100001	油表 COOLANT LEVEL GAUGE	3''	1
	0151	3560459A0	擋水板 WATER BAFFLE	7210\SPCC	1
	0160	3560461A0	孔蓋 HOLE COVER	7180\SPCC	1
	0190	3560606A0	擋水板 WATER BAFFLE	7210\SPCC	1

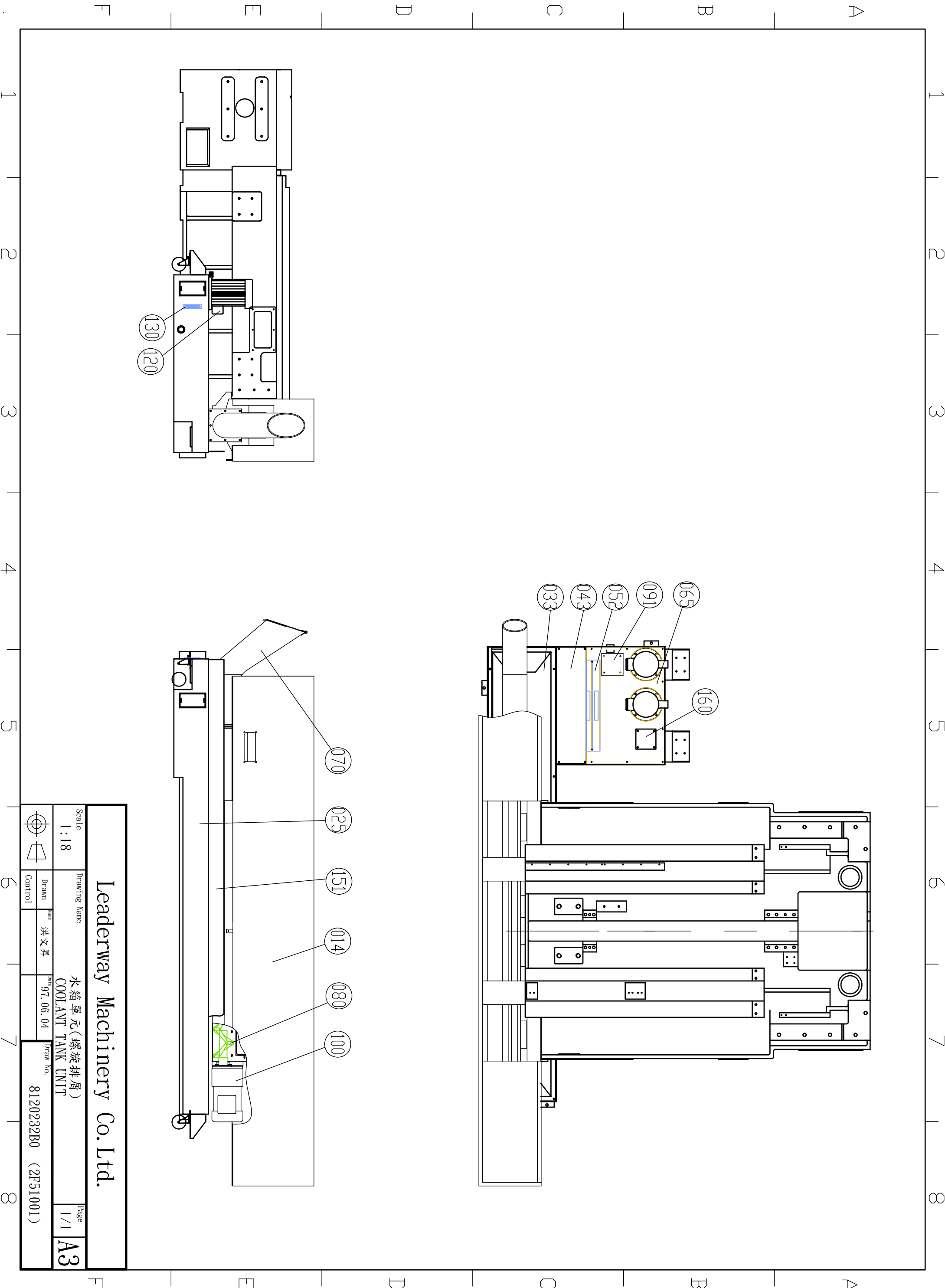

Leaderway Machinery Co. Ltd.

Scale		Drawing Name		Page	
1:18		水箱單元(螺旋排屑) COOLANT TANK UNIT		1/1	
Drawn	Checked	Draw No.	Draw No.		
Control	洪文昇	97.06.04	8120232B0 (2F51001)		

台灣力得衛宇龍科技股份有限公司

*單階材料用量清單

製表日期: 97-06-13

第1頁

主件品號	序號	元件品號	品名 英文品名	規 格	量
2F51005			水箱單元(龍船式) COOLANT UNIT (CHAIN TYPE CHIP CONVEYOR)	MV-1100S,D	
	0012	3560444D0	前下護罩 FRONT LOWER TELESCOPIC BARREL	7500\SPCC	1
	0020	3560428A0	水箱 COOLANT TANK	7580\SPCC	1
	0030	3560192B0	過濾網 FILTER NET	7590\SPCC	2
	0040	3560431A0	泵浦固定板 PUMP BRACKET	7180\SPCC	1
	0050	3560249B0	偵測器孔蓋 HOLE COVER	7180\SPCC	2
	0060	3560438B0	排屑機 CHIP CONVEYOR	9940\市購品	1
	0070	3560437A0	承屑盤 CHIP PLATE	7520\SPCC	1
	0080	4430040303	切削液泵浦(直立式) COOLANT PUMP	TPHK4T3-2S	2
	0100	4510100001	油表 COOLANT LEVEL GAUGE	3''	1
	0110	3560430B0	水箱蓋 COOLANT TANK COVER	7510\SPCC	1
	0120	3560461A0	孔蓋 HOLE COVER	7180\SPCC	1
	0130	3560606A0	擋水板 WATER BAFFLE	7210\SPCC	1

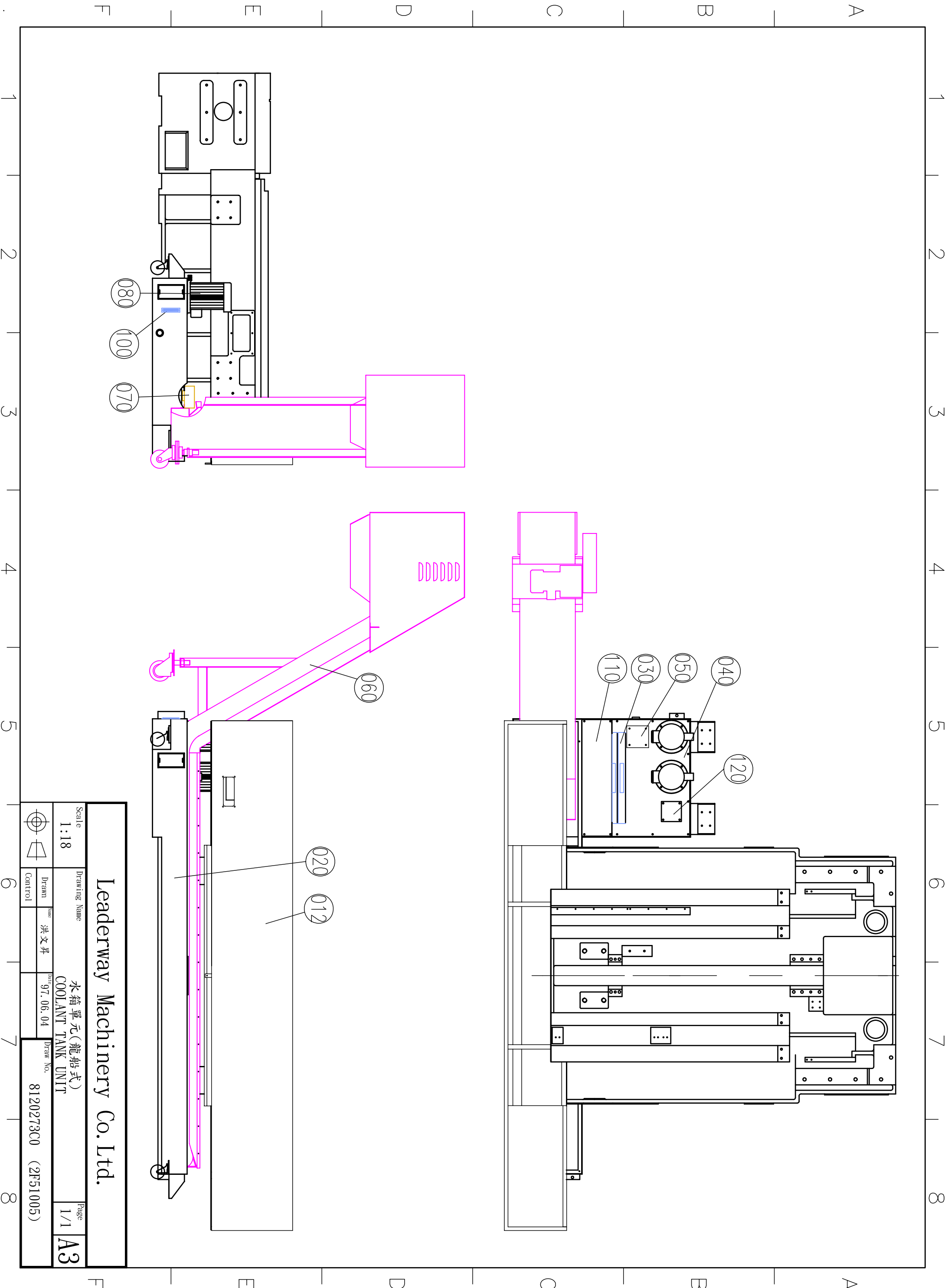

Leaderway Machinery Co. Ltd.

Scale		Drawing Name		Page	
1:18		水箱單元(龍船式) COOLANT TANK UNIT		1/1	
Drawn	Name	Date	Draw No.	A3	
Control	洪文昇	97.06.04	8120273C0 (2F51005)		

台灣力得衛宇龍科技股份有限公司

*單階材料用量清單

製表日期: 97-06-13

第1頁

主件品號	序號	元件品號	品名 英文品名	規 格	月量
2F51017			水箱單元/直型炮管(含螺旋排屑) COOLANT UNIT	V1100/MV1100S-D	
	0012	3560538C0	前下護罩 FRONT LOWER TELESCOPIC BARREL	7500\SPCC	1
	0023	3560545D0	水箱 COOLANT TANK	7580\SPCC	1
	0031	3560541B0	蓄屑槽一 FILTER NET(1)	7590\SPCC	1
	0041	3560543B0	水箱蓋一 COOLANT TANK COVER	7510\SPCC	1
	0050	3560542A0	蓄屑槽二 FILTER NET(2)	7590\SPCC	1
	0064	3560544E0	水箱蓋(泵浦) COOLANT TANK COVER(PUMP)	7510\SPCC	1
	0070	3560539A0	直型炮管(附防漏膠墊) CHIP THROUGH TUBE	7570\SPCC	1
	0080	3560434B0	捲屑器 CHIP CONVEYOR	4570\市購品	1
	0090	4440800016	排屑器馬達 CONVEYOR MOTOR	1/2HP 1:100 FME28	1
	0100	4430040303	切削液泵浦(直立式) COOLANT PUMP	TPHK4T3-2S	2
	0110	4510100001	油表 COOLANT LEVEL GAUGE	3''	1
	0120	3560461A0	孔蓋 HOLE COVER	7180\SPCC	1
	0130	3560540A0	蓄屑槽 FILTER NET	7590\SPCC	2
	0141	3560556B0	水箱蓋(泵浦)二 COOLANT TANK COVER(2)	7510\SPCC	1
	0150	3560606A0	擋水板 WATER BAFFLE	7210\SPCC	1

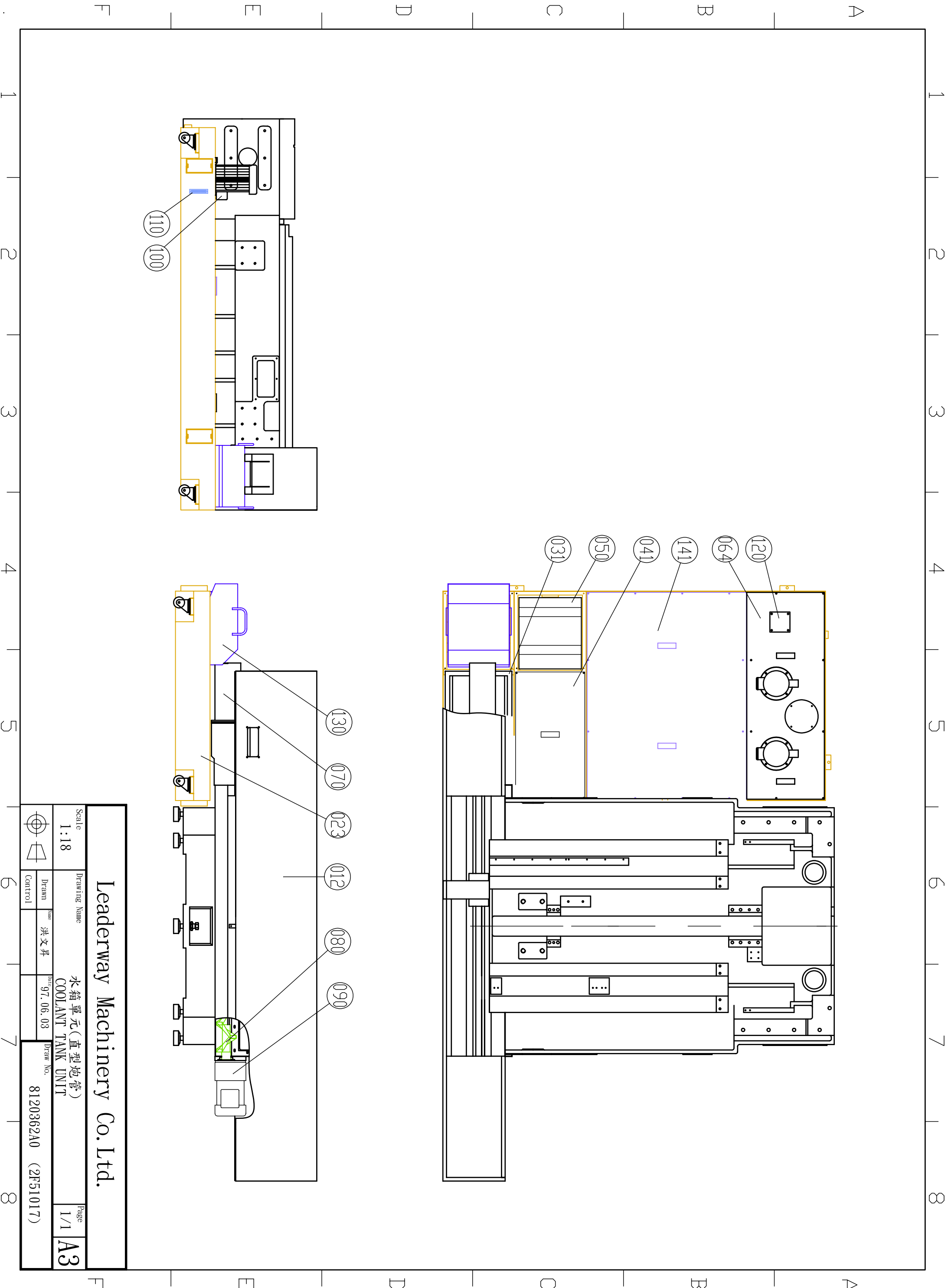

Leaderway Machinery Co. Ltd.

Scale		Drawing Name		Page	
1:18		水箱單元 (直型炮管) COOLANT TANK UNIT		1/1	
Drawn	Control	Drawn	Control	Draw No.	
洪文昇		洪文昇		8120362A0 (2F51017)	
				97.06.03	

台灣力得衛宇龍科技股份有限公司

*單階材料用量清單

製表日期: 99-08-17

第1頁

主件品號	序號	元件品號	品名 英文品名	規 格	月量
2F51003			水箱單元 COOLANT TANK UNIT	MV-1300S/MV-1300D	
	0014	3570104D0	前下護罩(機內螺旋) FRONT LOWER TELESCOPIC BARRE	7500\SPCC	1
	0025	3560428A0	水箱 COOLANT TANK	7580\SPCC	1
	0033	3560429C0	水箱蓋 COOLANT TANK COVER	7510\SPCC	1
	0043	3560430B0	水箱蓋 COOLANT TANK COVER	7510\SPCC	1
	0052	3560192B0	過濾網 FILTER NET	7590\SPCC	2
	0067	3560431C0	泵浦固定板 PUMP BRACKET	7180\SPCC	1
	0070	3560433B0	排屑炮管(附蓋及防漏膠墊) CHIP THROUGH TUBE	7570\SPCC	1
	0080	3570105B0	捲屑器 CHIP CONVEYOR	4570\市購品	1
	0091	3560249B0	偵測器孔蓋 HOLE COVER	7180\SPCC	1
	0100	4440800016	排屑器馬達 CONVEYOR MOTOR	1/2HP 1:100 FME28	1
	0120	4430040303	切削液泵浦(直立式) COOLANT PUMP	TPHK4T3-2S	2
	0130	4510100001	油表 COOLANT LEVEL GAUGE	3''	1
	0141	3560459A0	擋水板 WATER BAFFLE	7210\SPCC	1
	0180	3560235A0	左下飾板 (L) LOWER PLATE	7510\SPCC	1
	0190	3560606A0	擋水板 WATER BAFFLE	7210\SPCC	1

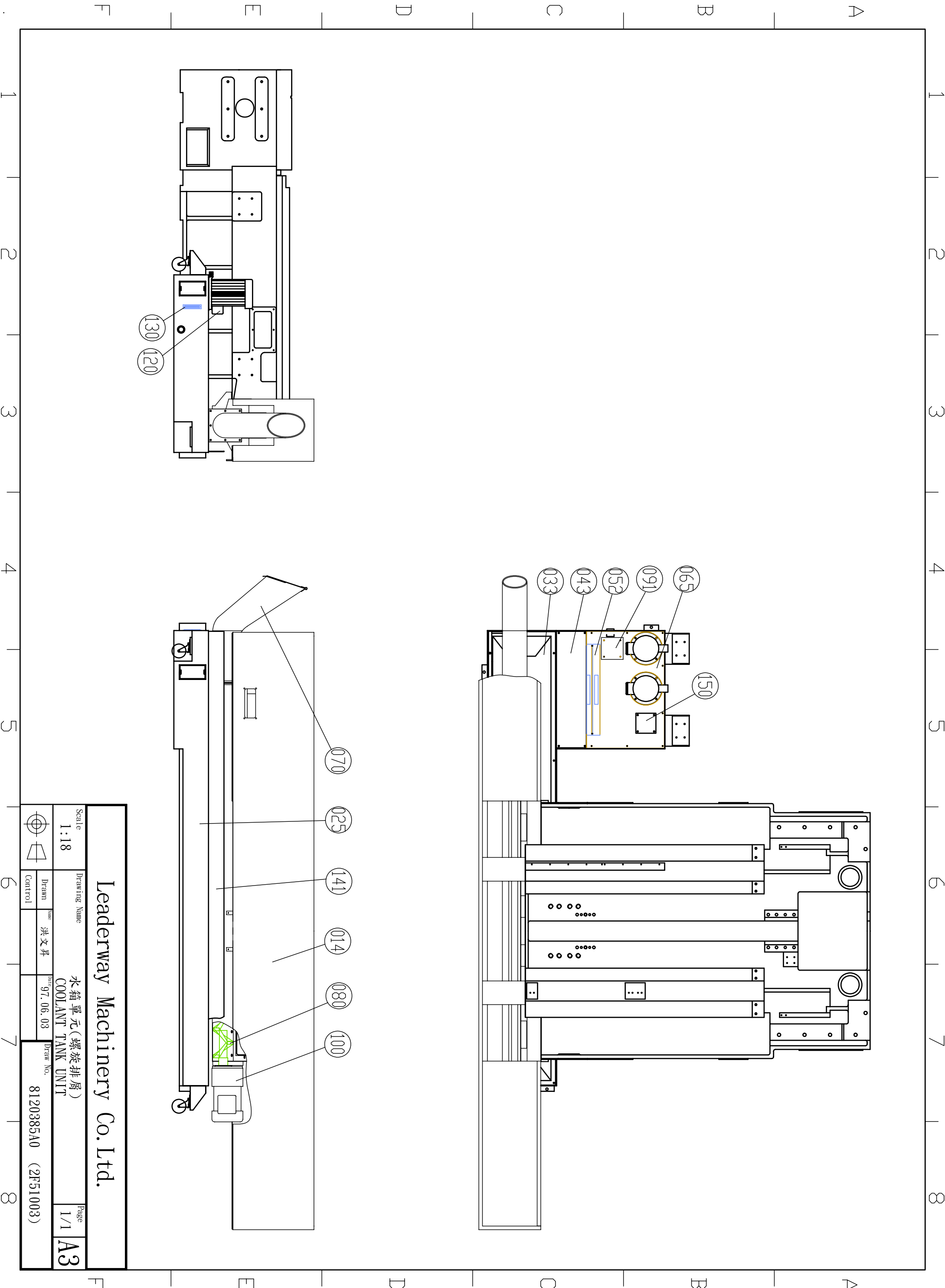

Leaderway Machinery Co. Ltd.

Scale		Drawing Name		Page	
1:18		水箱單元(螺旋排屑) COOLANT TANK UNIT		1/1	
Drawn	Checked	Date	Draw No.	A3	
Control	洪文昇	97.06.03	8120385A0 (2F51003)		

台灣力得衛宇龍科技股份有限公司

*單階材料用量清單

製表日期: 99-08-17

第1頁

主件品號	序號	元件品號	品名 英文品名	規 格	月量
2F51006			水箱單元(龍船式) COOLANT UNIT (CHAIN TYPE CHI	MV-1300S,D	
	0012	3570081E0	前下護罩 FRONT LOWER TELESCOPIC BARRE	7500\SPCC	1
	0020	3560428A0	水箱 COOLANT TANK	7580\SPCC	1
	0030	3560192B0	過濾網 FILTER NET	7590\SPCC	2
	0042	3560431C0	泵浦固定板 PUMP BRACKET	7180\SPCC	1
	0050	3560249B0	偵測器孔蓋 HOLE COVER	7180\SPCC	1
	0060	3560438B0	排屑機 CHIP CONVEYOR	9940\市購品	1
	0070	3560437A0	承屑盤 CHIP PLATE	7520\SPCC	1
	0080	4430040303	切削液泵浦(直立式) COOLANT PUMP	TPHK4T3-2S	2
	0100	4510100001	油表 COOLANT LEVEL GAUGE	3''	1
	0110	3560430B0	水箱蓋 COOLANT TANK COVER	7510\SPCC	1
	0130	3560606A0	擋水板 WATER BAFFLE	7210\SPCC	1

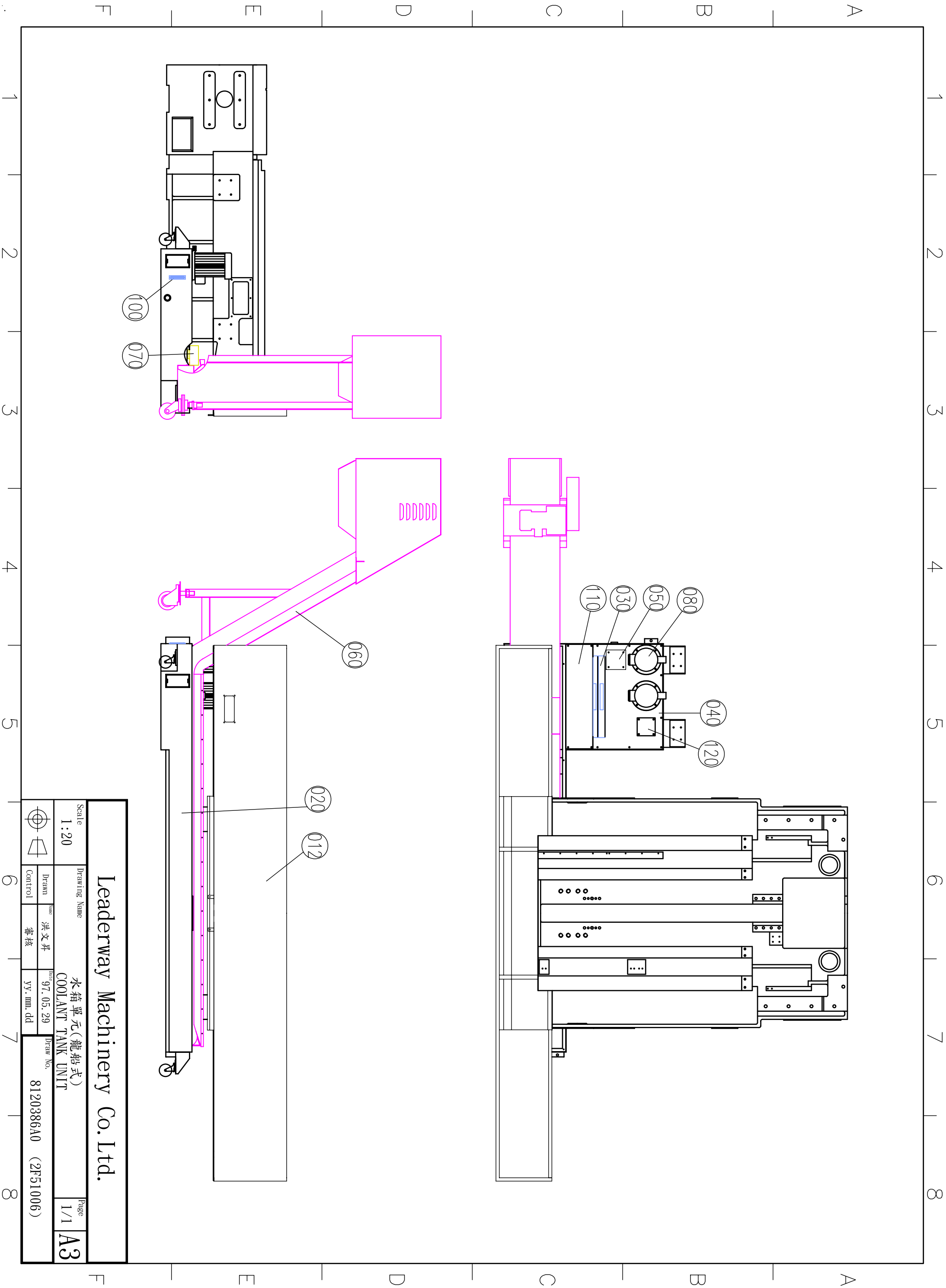

Leaderway Machinery Co. Ltd.

Scale		Drawing Name		Date		Page	
1:20		水箱單元(龍船式) COOLANT TANK UNIT		97.05.29		1/1	
Drawn		Name		Unit		Draw No.	
Control		洪文昇		yy. mm. dd		8120386A0 (2F51006)	
		審核					

台灣力得衛宇龍科技股份有限公司

*單階材料用量清單

製表日期: 99-08-17

第1頁

主件品號	序號	元件品號	品名 英文品名	規 格	月量
2F51018			水箱單元(直型炮管) COOLANT TANK UNIT	MV-1300S/MV-1300D	
	0012	3570143C0	前下護罩 FRONT LOWER TELESCOPIC BARRE	7500\SPCC	1
	0023	3560545D0	水箱 COOLANT TANK	7580\SPCC	1
	0031	3560541B0	蓄屑槽一 FILTER NET(1)	7590\SPCC	1
	0041	3560543B0	水箱蓋一 COOLANT TANK COVER	7510\SPCC	1
	0050	3560542A0	蓄屑槽二 FILTER NET(2)	7590\SPCC	1
	0066	3560544G0	水箱蓋(泵浦) COOLANT TANK COVER(PUMP)	7510\SPCC	1
	0070	3560539A0	直型炮管(附防漏膠墊) CHIP THROUGH TUBE	7570\SPCC	1
	0080	3570105B0	捲屑器 CHIP CONVEYOR	4570\市購品	1
	0100	4440800016	排屑器馬達 CONVEYOR MOTOR	1/2HP 1:100 FME28	1
	0110	4430040303	切削液泵浦(直立式) COOLANT PUMP	TPHK4T3-2S	2
	0120	4510100001	油表 COOLANT LEVEL GAUGE	3''	1
	0150	3560540A0	蓄屑槽 FILTER NET	7590\SPCC	2
	0161	3560556B0	水箱蓋(泵浦)二 COOLANT TANK COVER(2)	7510\SPCC	1
	0170	3560606A0	擋水板 WATER BAFFLE	7210\SPCC	1

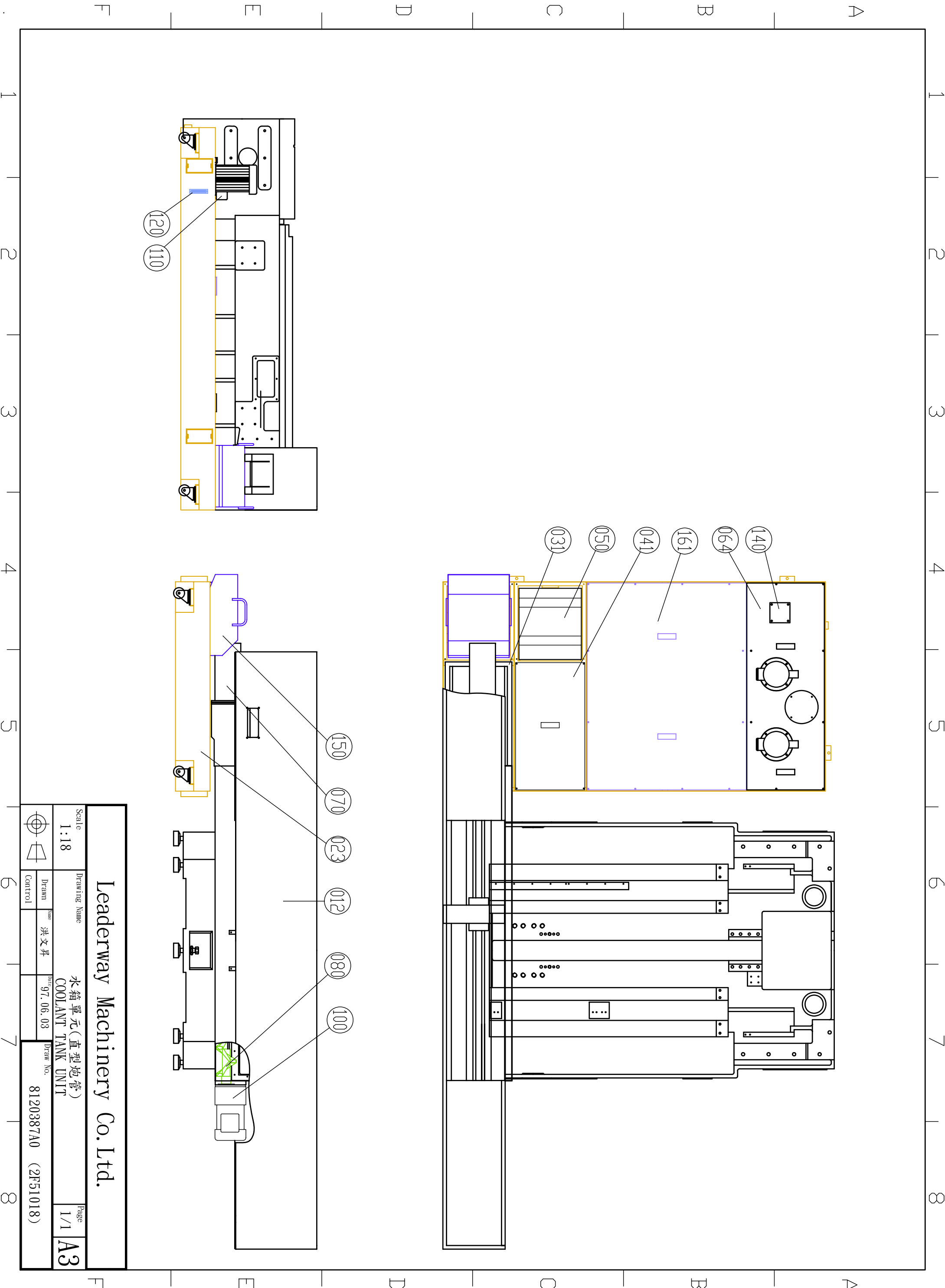

Leaderway Machinery Co. Ltd.

Scale		Drawing Name		Page	
1:18		水箱單元 (直型炮管) COOLANT TANK UNIT		1/1	
Drawn	Checked	Draw No.	A3		
Control	洪文昇	97.06.03	8120387A0 (2F51018)		

台灣力得衛宇龍科技股份有限公司

*單階材料用量清單

製表日期: 99-08-17

第1頁

主件品號	序號	元件品號	品名 英文品名	規 格	月量
2F52001			電氣箱單元/熱交換器 POWER CABINET UNIT	V1100/MV1100S-D/MV1300S-D	
	0011	3500150C0	左右調整座 ADJUSTABLE BRACKET	7160\SPCC	1
	0023	3560382E0	電氣箱 POWER CABINET	7450\SPCC	1
	0030	3560411A0	電氣箱左門 (L) DOOR, POWER CABINET	7450\SPCC	1
	0040	3500149B0	主電源開關座 MAIN POWER SWITCH BRACKET	7160\SPCC	1
	0051	3570062B0	電氣箱架 POWER CABINET BRACKET	7450\SPCC	1
	0060	3570063A0	電氣箱架蓋 COVER, POWER CABINET BRACKET	7450\SPCC	1
	0070	4560300025	熱交換器 HEAT EXCHANGER	HPW-25AR(箱內型)	1
	0081	3560412B0	電氣箱右門 (R) DOOR, POWER CABINET	7450\SPCC	1
	0090	3500409A0	讀帶機蓋板 COVER	7180\SPCC	1

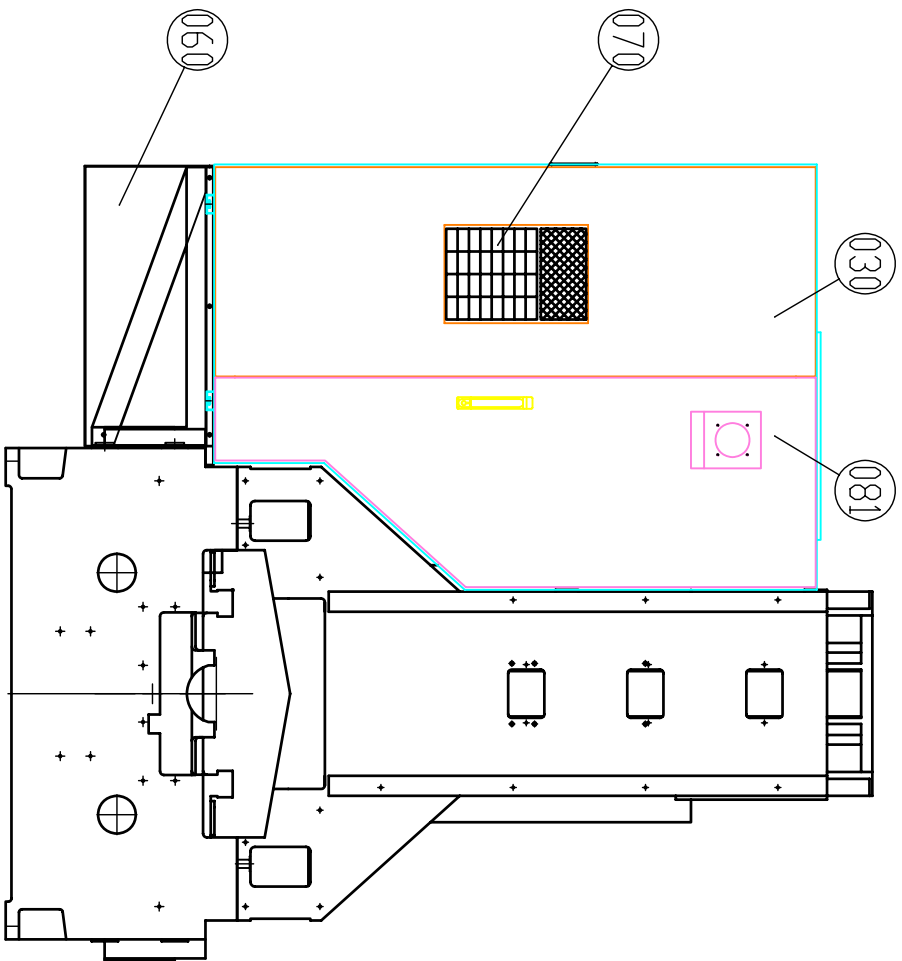
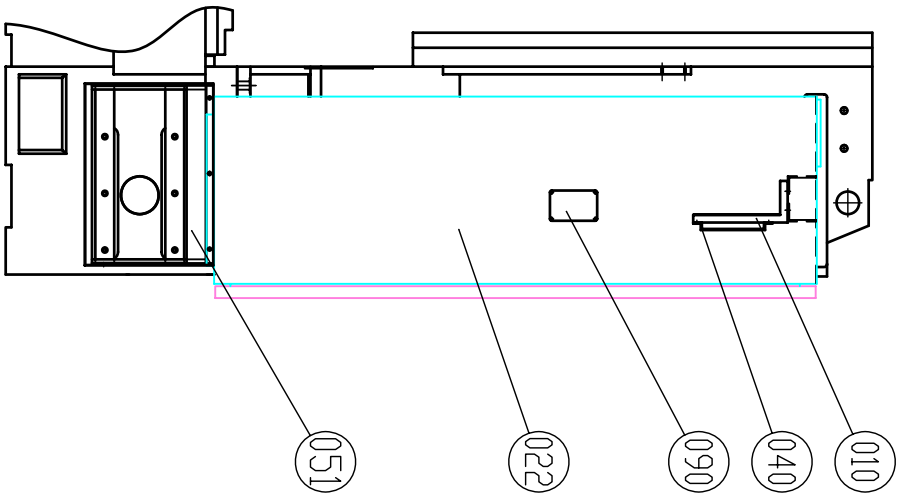

Leaderway Machinery Co. Ltd.

Scale
1:20

Drawing Name

電器箱單元 (ELECTRIC BOX)

Page
1/1

A4



Drawn
Control

Name
徐維駿
審核

Date
97.05.14
yy.mm.dd

Draw No.

8120220B0(2F52001)

台灣力得衛宇龍科技股份有限公司

*單階材料用量清單

製表日期: 99-08-17

第1頁

主作品號	序號	元作品號	品名 英文品名	規 格	月量
2F53002			操作箱單元 F 0iMC-PA OPERATION CABINET UNIT	V1100/MV1100S-D/MV1300S-D	
	0014	3500432E0	操作箱(FANUC Oi MC) OPERATION CABINET	7460\SPCC	1
	0022	3500433C0	操作箱後蓋 CABINET REAR COVER	7460\SPCC	1
	0030	3500129A0	旋轉座 ROTATION BRACKET	3240\S45C	1
	0040	4300400400	管型把手(自然色) HANDLE	U1-400L	1
	0051	4720632243	警示燈(三層) WARNING LIGHT	GSL-24V-3-B	1
	0062	3560384E0	伸臂 OUTSTRETCHED ARM	7470\SPCC	1
	0071	3560388C0	驅動器固定架(A) FIXED BRACKET(A), DRIVER	7560\SPCC	1
	0084	3560389E0	驅動器固定架(B) FIXED BRACKET(B), DRIVER	7560\SPCCZ	1
	0092	3570054F0	I/O基板 I/O BOARD	7560\SPCCZ	1
	0101	3580026D0	警示燈座 WARNING LIGHT BRACKET	7180\SPCC	1
	0110	3580037A0	伸臂蓋板 OUTSTRETCHED ARM COVER	7180\SPCC	4
	0120	3580039B0	伸臂連結蓋板 OUTSTRETCHED ARM CONNECTING	7180\SPCC	1
	0130	3560633A0	高低檔開關固定板 FIXED PLATE	7180\SPCC	1
	0140	4650105012	I型橡膠避震器 CUSHION PAD	YS-12I(M5) M5-M5-φ16-15L	4

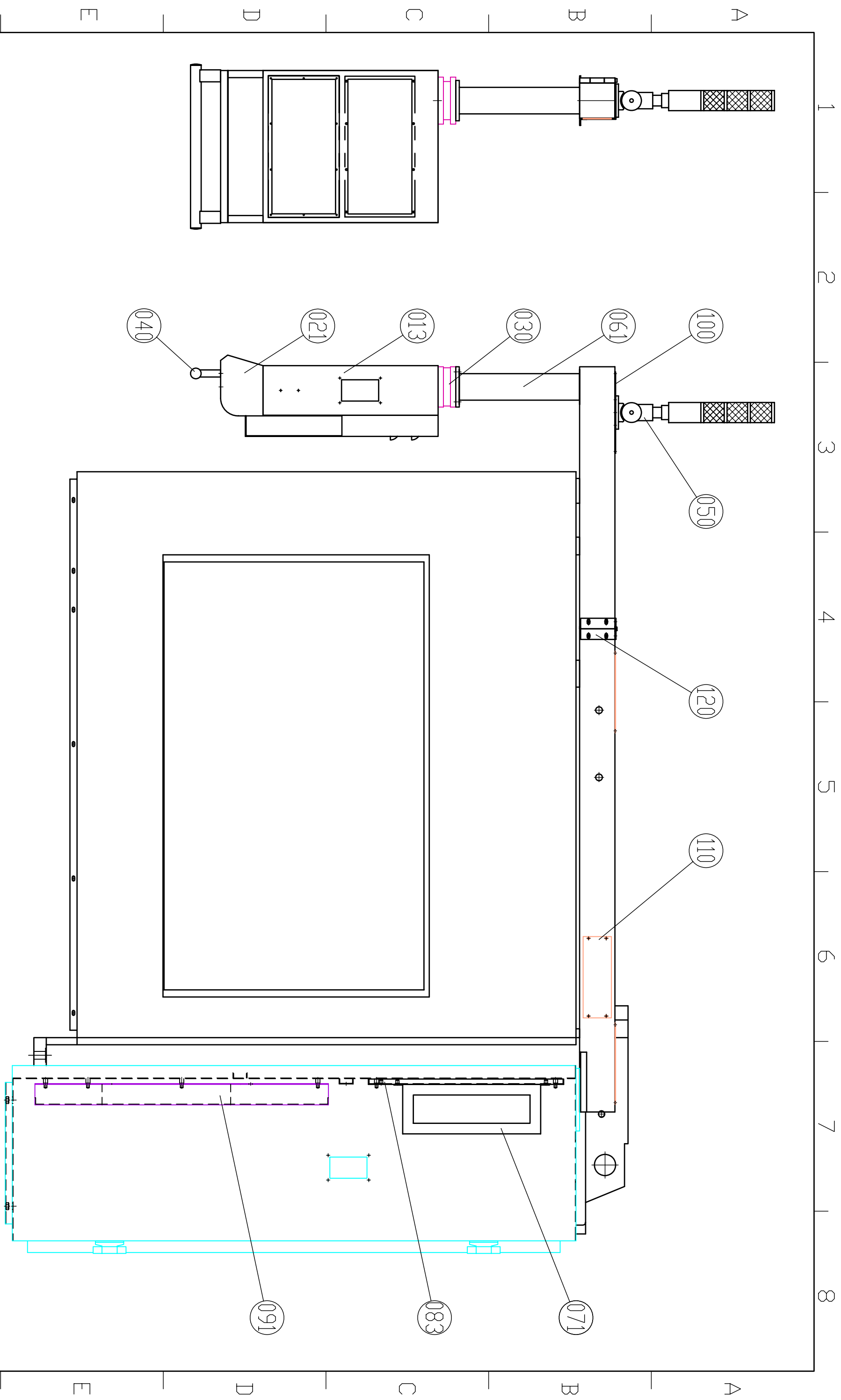

Leaderway Machinery Co. Ltd.

Scale 1:10		Drawing Name 操作箱單元 0iMC-PA OPERATION UNIT 0iMC-PA		Page 1/1	
Drawn Control		Name 徐維駿		Date 97.05.15	
Control		審核		Draw No. 8120283C0 (2F53002)	

A3

台灣力得衛宇龍科技股份有限公司

*單階材料用量清單

製表日期: 99-08-17

第1頁

主作品號	序號	元作品號	品名 英文品名	規 格	月量
2F53004			操作箱單元 F 18i OPERATION CABINET UNIT	V1100	
	0014	3580269B0	操作箱 OPERATION CABINET	7460\SPCC	1
	0022	3580270B0	操作箱後蓋 CABINET REAR COVER	7460\SPCC	1
	0030	3500129A0	旋轉座 ROTATION BRACKET	3240\S45C	1
	0040	4300400400	管型把手(自然色) HAHDLE	U1-400L	1
	0051	4720632243	警示燈(三層) WARNING LIGHT	GSL-24V-3-B	1
	0062	3560384E0	伸臂 OUTSTRETCHED ARM	7470\SPCC	1
	0071	3560388C0	驅動器固定架(A) FIXED BRACKET(A), DRIVER	7560\SPCC	1
	0084	3560389E0	驅動器固定架(B) FIXED BRACKET(B), DRIVER	7560\SPCCZ	1
	0092	3570054F0	I/O基板 I/O BOARD	7560\SPCCZ	1
	0101	3580026D0	警示燈座 WARNING LIGHT BRACKET	7180\SPCC	1
	0110	3580037A0	伸臂蓋板 OUTSTRETCHED ARM COVER	7180\SPCC	4
	0120	3580039B0	伸臂連結蓋板 OUTSTRETCHED ARM CONNECTING	7180\SPCC	1
	0130	3560633A0	高低檔開關固定板 FIXED PLATE	7180\SPCC	1
	0140	4650105012	I型橡膠避震器 CUSHION PAD	YS-12I(M5) M5-M5-φ16-15L	4

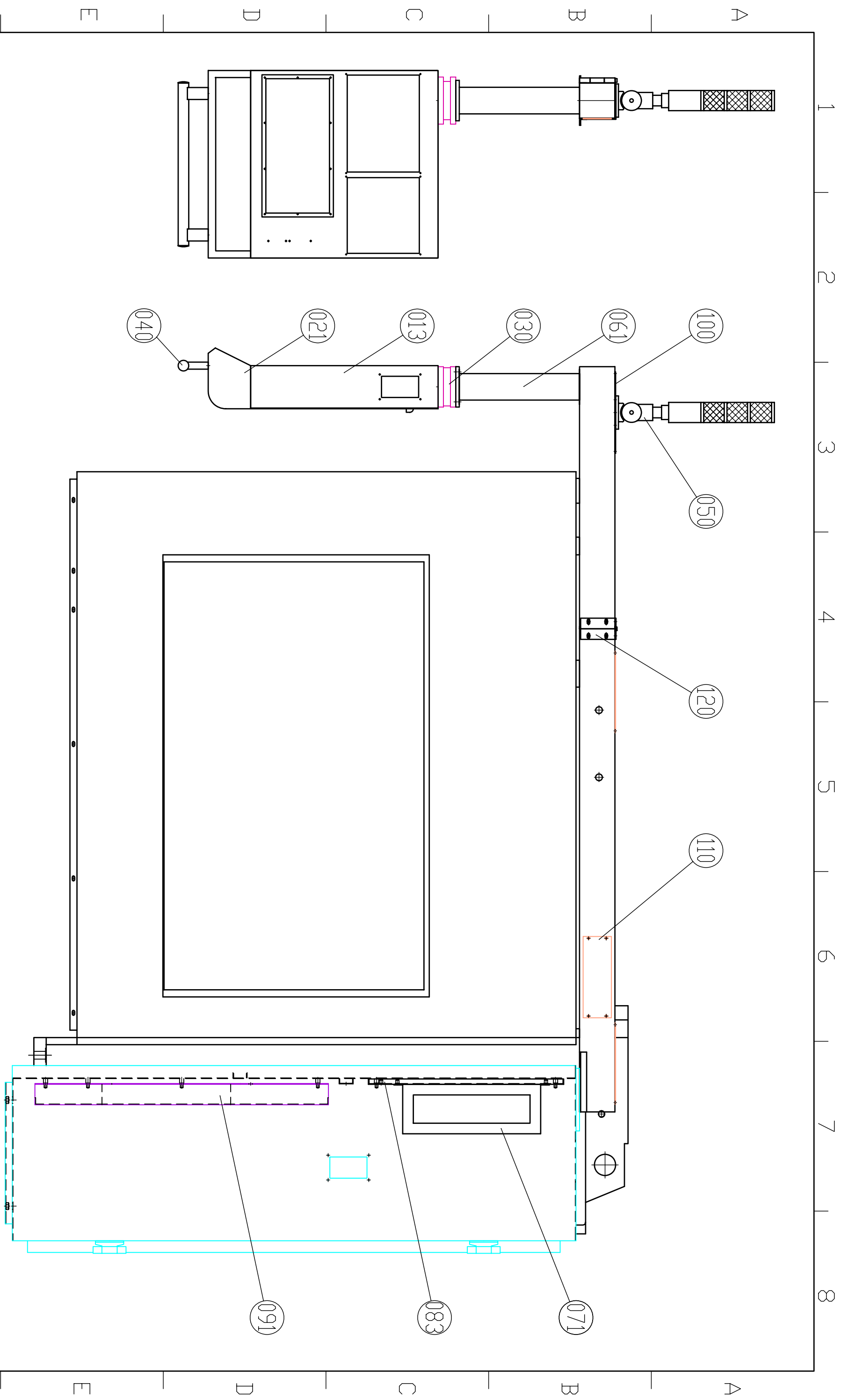

Leaderway Machinery Co. Ltd.

Scale 1:10		Drawing Name 操作箱單元 F 18i OPERATION UNIT F 18i		Page 1/1	
Drawn Control	Name 徐維駿	Date 97.06.18	Unit yy-mm-dd	Draw No. 8120117C0 (2F53004)	Page A3
		審核			

台灣力得衛宇龍科技股份有限公司

*單階材料用量清單

製表日期: 97-06-13

第1頁

主件品號	序號	元件品號	品名 英文品名	規 格	量
2F53023			操作箱單元 三菱-65M OPERATION CABINET UNIT	V-1100S/MV-1100S	
	0010	3560522A0	操作箱 OPERATION CABINET	7460\SPCC	1
	0020	3560523A0	操作箱後蓋 CABINET REAR COVER	7460\SPCC	1
	0030	3500129A0	旋轉座 ROTATION BRACKET	3240\S45C	1
	0040	4300400400	管型把手(自然色) HAHDLE	U1-400L	1
	0050	4720635243	警示燈(三層) WARNING LIGHT	SPE-35-24-3-B0-10 RYG	1
	0061	3560384D0	伸臂 OUTSTRETCHED ARM	7470\SPCC	1
	0082	3560389D0	驅動器固定架(B) FIXED BRACKET(B), DRIVER	7560\SPCCZ	1
	0091	3570054E0	I/O基板 I/O BOARD	7560\SPCCZ	1
	0100	3580026C0	警示燈座 WARNING LIGHT BRACKET	7180\SPCC	1
	0110	3580037A0	伸臂蓋板 OUTSTRETCHED ARM COVER	7180\SPCC	4
	0120	3580039B0	伸臂連結蓋板 OUTSTRETCHED ARM CONNECTING BRACKET	7180\SPCC	1
	0130	3560536A0	保護蓋 PROTECTING COVER	7510\SPCC	1

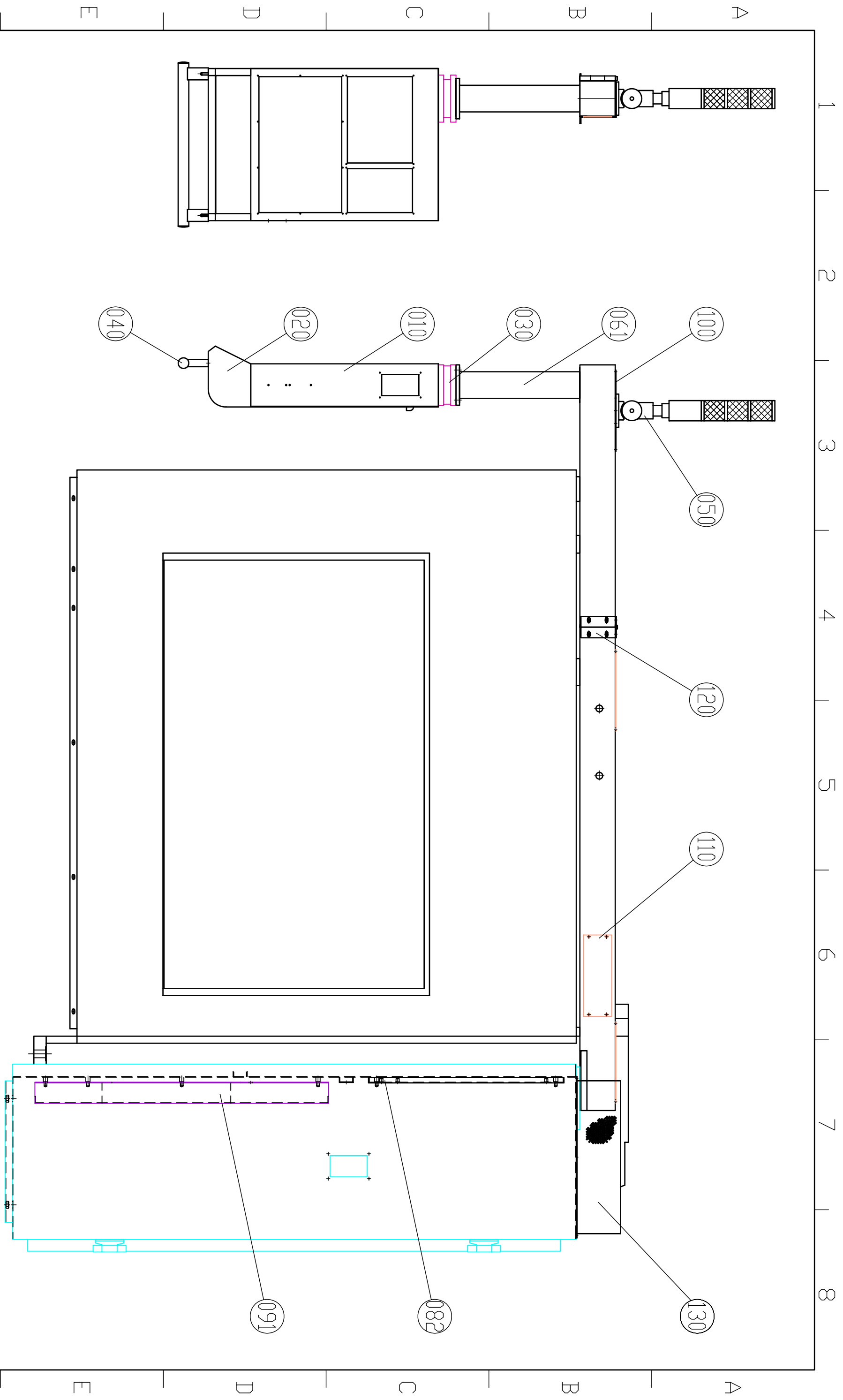

Leaderway Machinery Co. Ltd.

Scale 1:10		Drawing Name 操作箱單元 Meldas 65M OPERATION UNIT Meldas 65M		Page 1/1	
Drawn Control	Name 徐維駿	Date 97.06.05	Draw No. 8120237C0 (2F53023)	A3	
	審核	yy. mm. dd			

台灣力得衛宇龍科技股份有限公司

*單階材料用量清單

製表日期: 99-08-17

第1頁

主件品號	序號	元件品號	品名 英文品名	規 格	月量
2F53026			操作箱單元 H.D.H iTNC530i OPERATION CABINET UNIT	MV1100S/1300S	
	0013	3560602C0	操作箱(H.D.H 530i) OPERATION CABINET	7460\SPCC\MV1100S\MV1300S	1
	0020	3560391A0	操作箱後蓋 CABINET REAR COVER	7460\SPCC	1
	0030	3500129A0	旋轉座 ROTATION BRACKET	3240\S45C	1
	0040	4300400400	管型把手(自然色) HANDLE	U1-400L	1
	0051	4720632243	警示燈(三層) WARNING LIGHT	GSL-24V-3-B	1
	0061	3560384E0	伸臂 OUTSTRETCHED ARM	7470\SPCC	1
	0072	3560389E0	驅動器固定架(B) FIXED BRACKET(B), DRIVER	7560\SPCCZ	1
	0081	3570054F0	I/O基板 I/O BOARD	7560\SPCCZ	1
	0100	3580037A0	伸臂蓋板 OUTSTRETCHED ARM COVER	7180\SPCC	5
	0110	3580039B0	伸臂連結蓋板 OUTSTRETCHED ARM CONNECTING	7180\SPCC	1
	0160	3560642A0	手輪固定架 BRACKET OF MPG	7210\SPCC	1

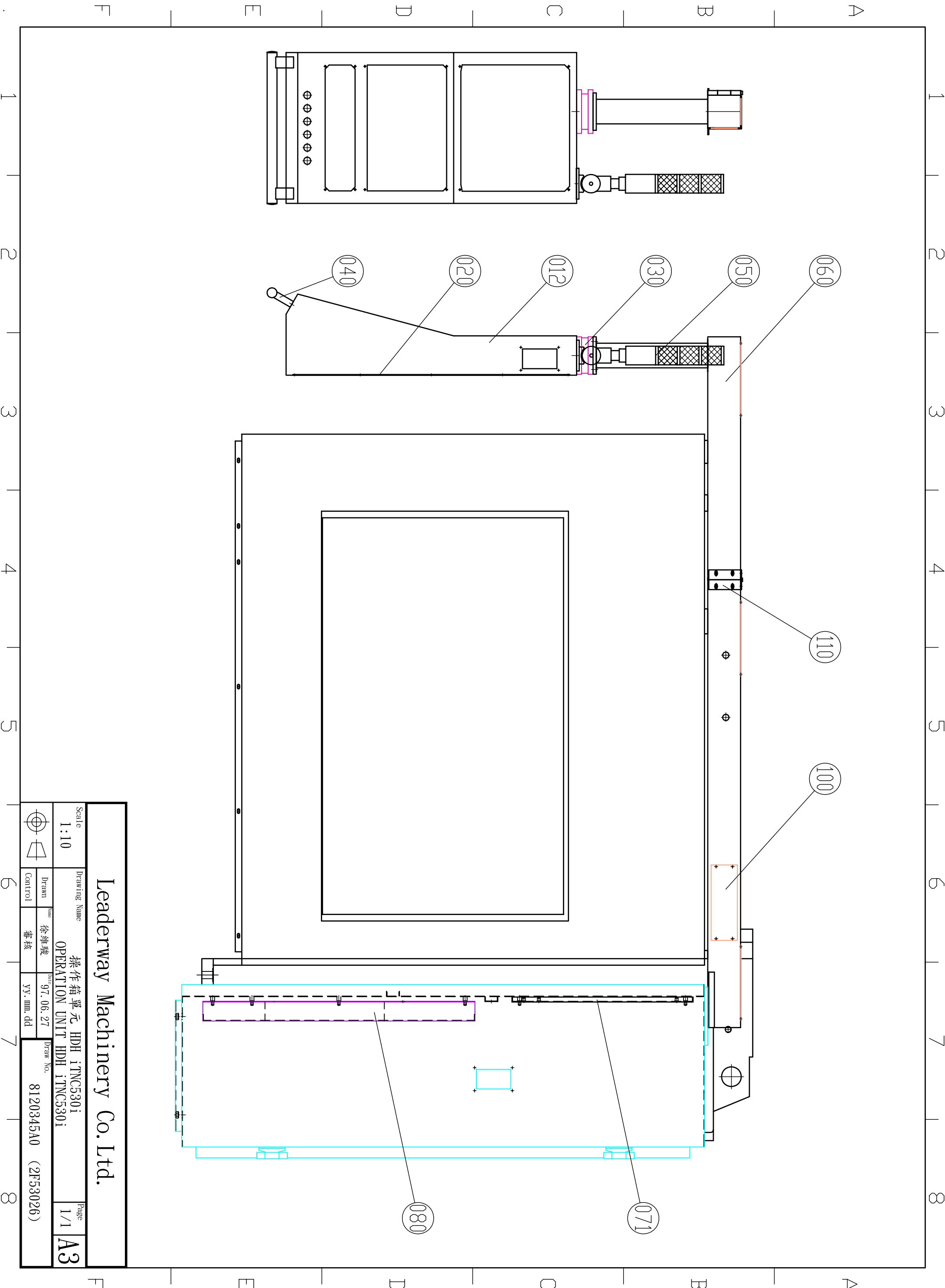

Leaderway Machinery Co. Ltd.

Scale 1:10		Drawing Name 操作箱單元 HDH iTNC530i OPERATION UNIT HDH iTNC530i		Page 1/1	
Drawn Control	Name 徐維駿	Date 97.06.27	Draw No. 8120345A0 (2F53026)	A3	
	審核	yy-mm-dd			