



Leaderway *VERTICAL MACHINING CENTER
(LINEAR GUIDE WAY)*

VERTICAL MACHINING CENTER

PARTS LIST

V33i\V42i

LEADERWAY CNC TECHNOLOGIES CO., LTD.

NO. 36, Ln. 211, Taiming Rd.,
Wuri Dist, TAICHUNG 41468, TAIWAN

TEL: +886-4-2335-0711

FAX: +886-4-2335-0986



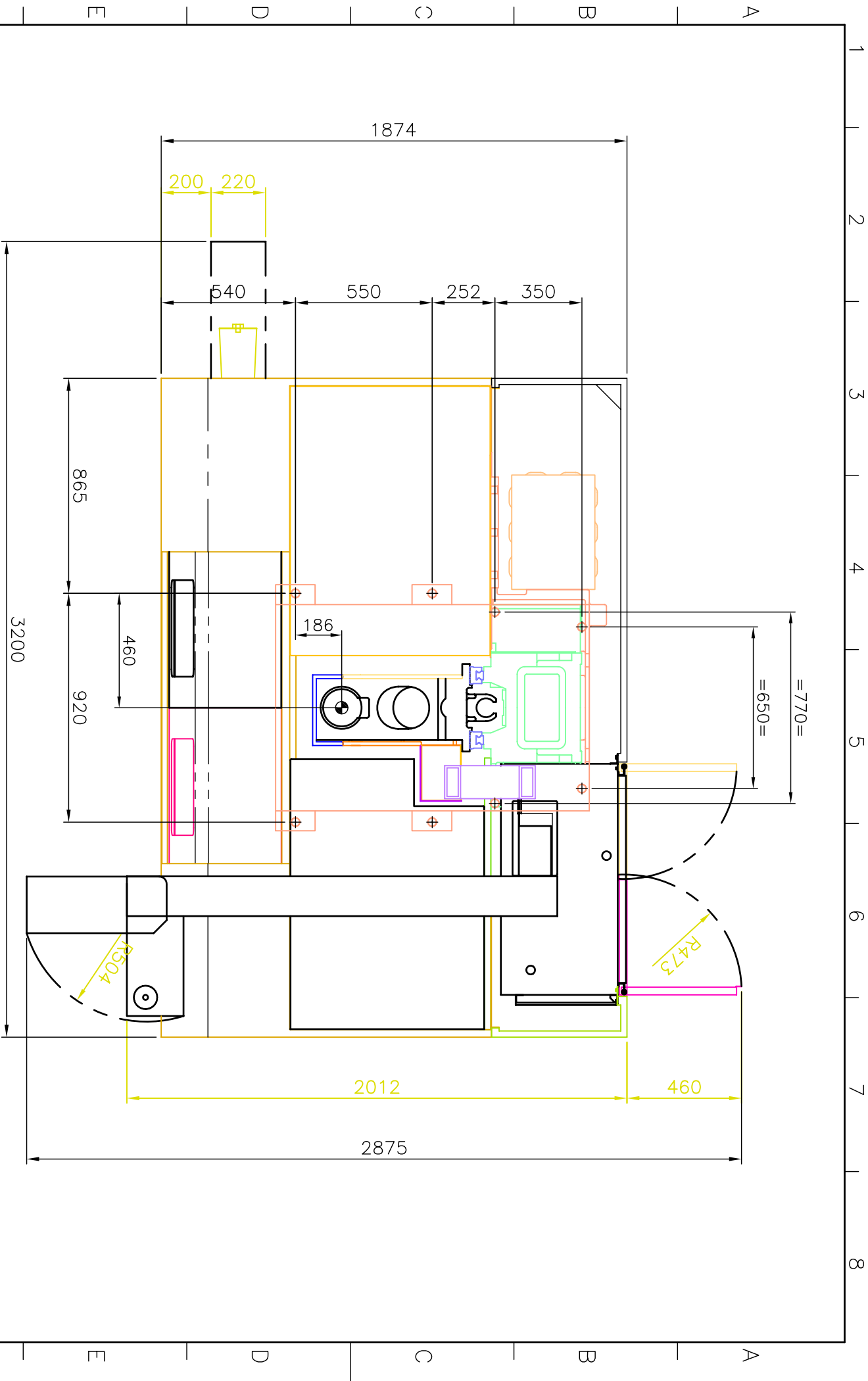

Leaderway Machinery Co. Ltd.

Scale	1:14	Drawing Name	OUTLING DIMENSION (TOP VIEW) 外型尺寸圖	Page	1/3
Drawn	AMY	Date	97.04.28	Draw No.	815012280 (Y421)
Control					

A3

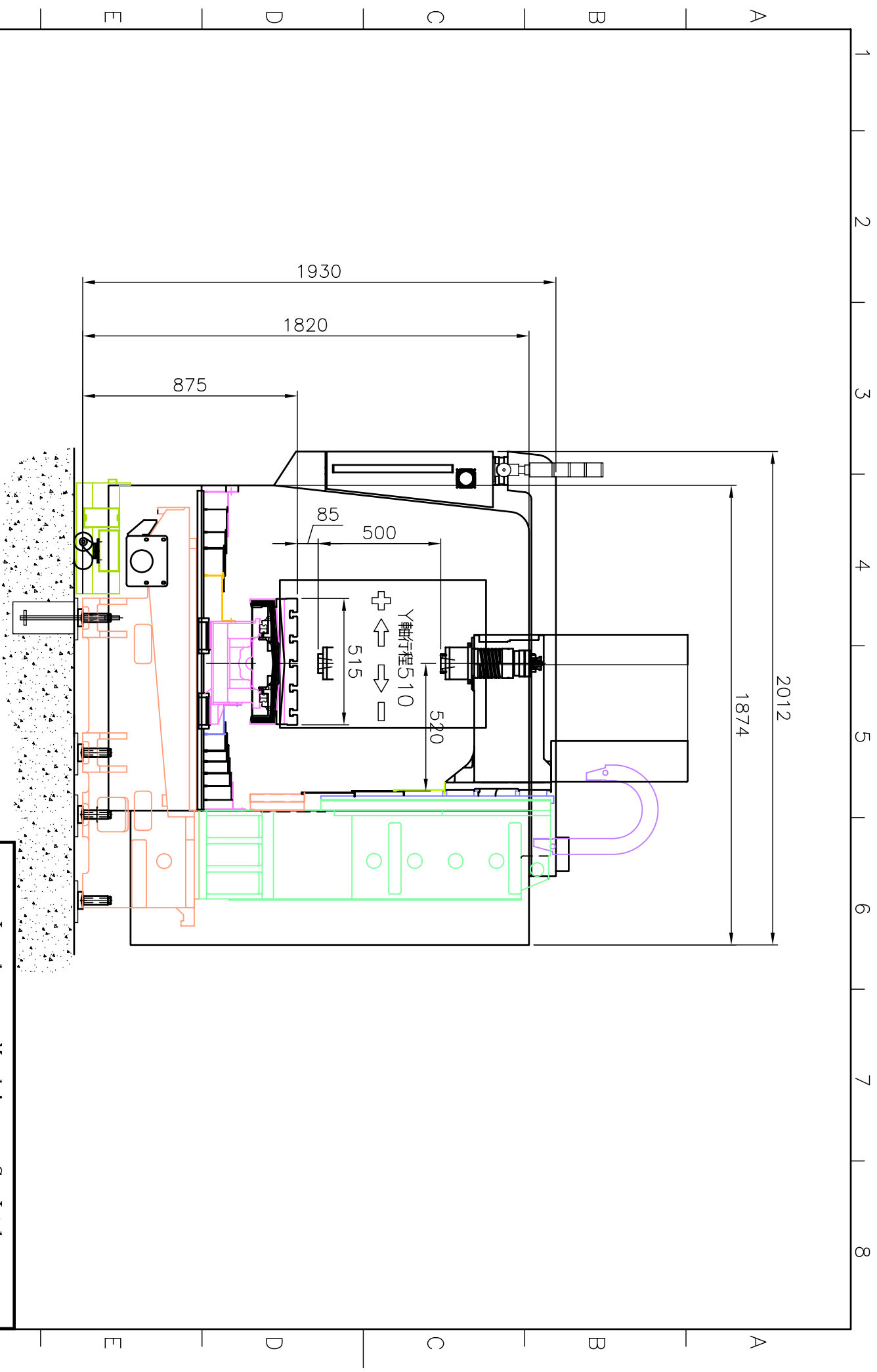

Leaderway Machinery Co. Ltd.			
Scale	Drawing Name	Page	
1:14	OUTLING DIMENSION (RIGHT SIDE VIEW) 外型尺寸圖	2/3	A3
Drawn	Drawn	Design	Draw No.
Control	AMY	37.04.28	815012280 (Y421)

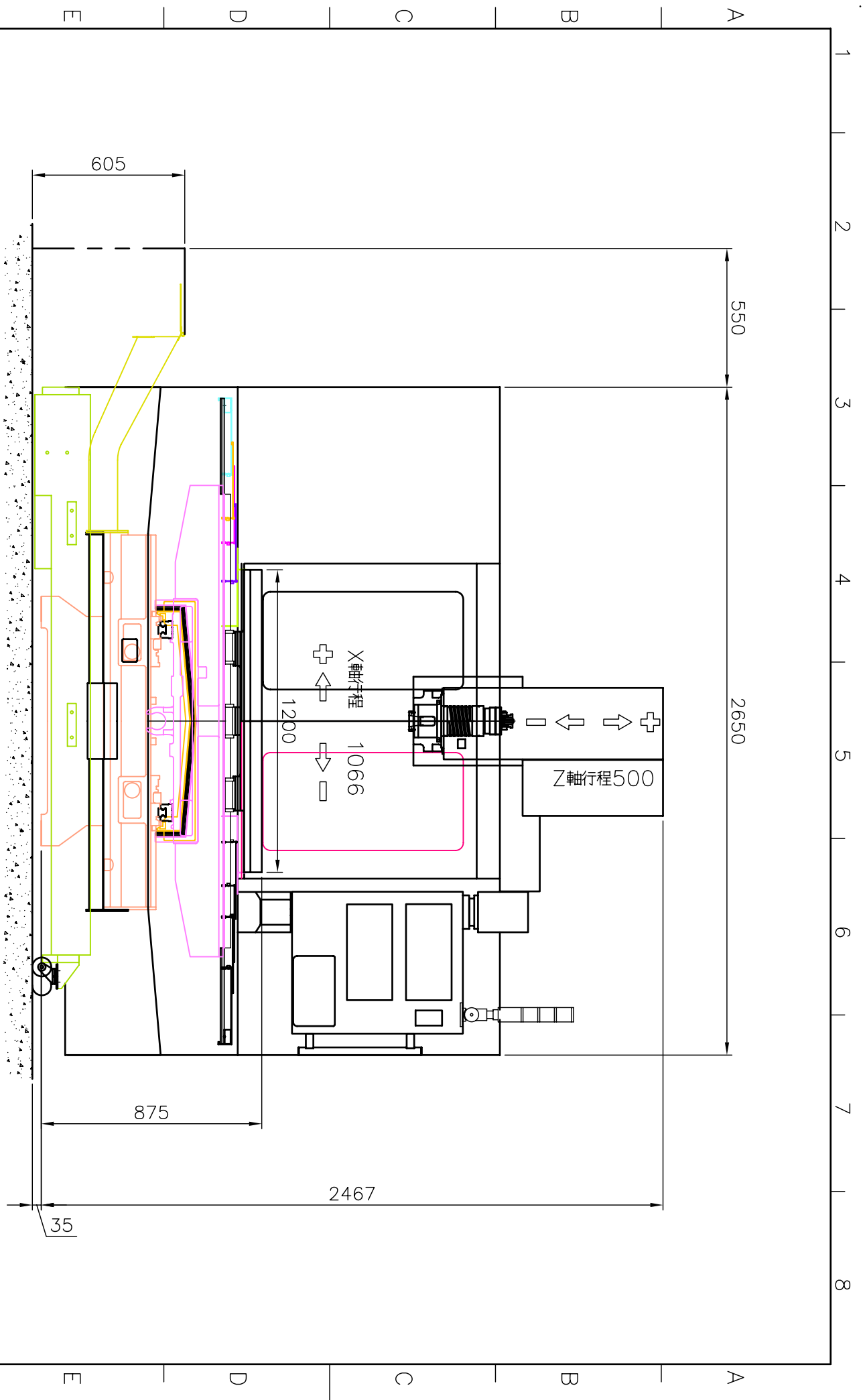

Leaderway Machinery Co. Ltd.

Scale	Drawing Name		Page
1:14	OUTLING DIMENSION (FRONT VIEW) 外型尺寸圖		3/3
Drawn	Drawn	Draw No.	A3
Control	ANY	815012280 (V421)	

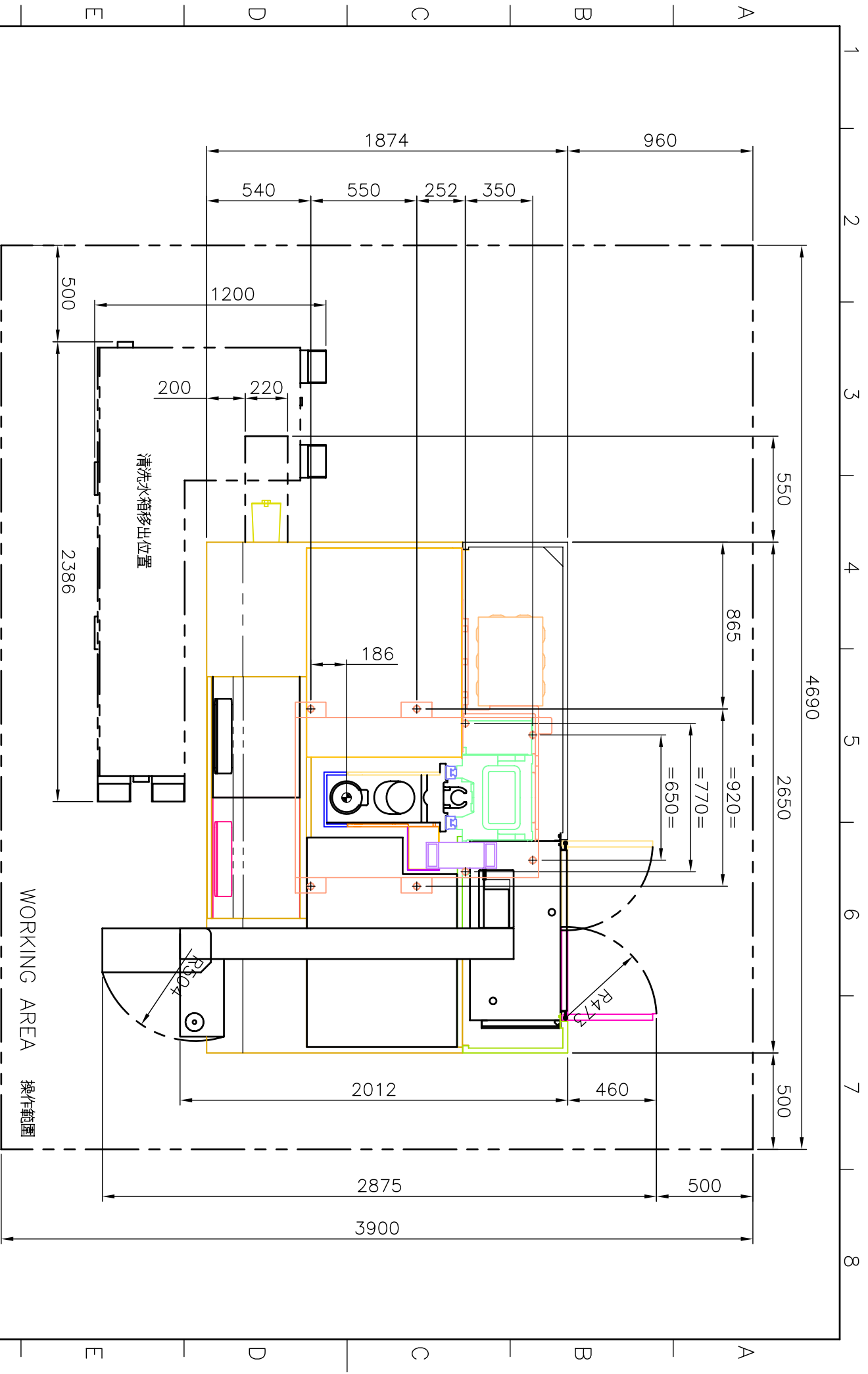

Leaderway Machinery Co. Ltd.

Scale	1:18			Page	1/2
Drawing Name	FOUNDATION ANCHOR SET UP DRAWING (地基圖)			A3	
Drawn	卜環云	Date	97.09.08		
Control	審核	yy.mm.dd			
Draw No.	8150122B0 (V421+標準水箱)				

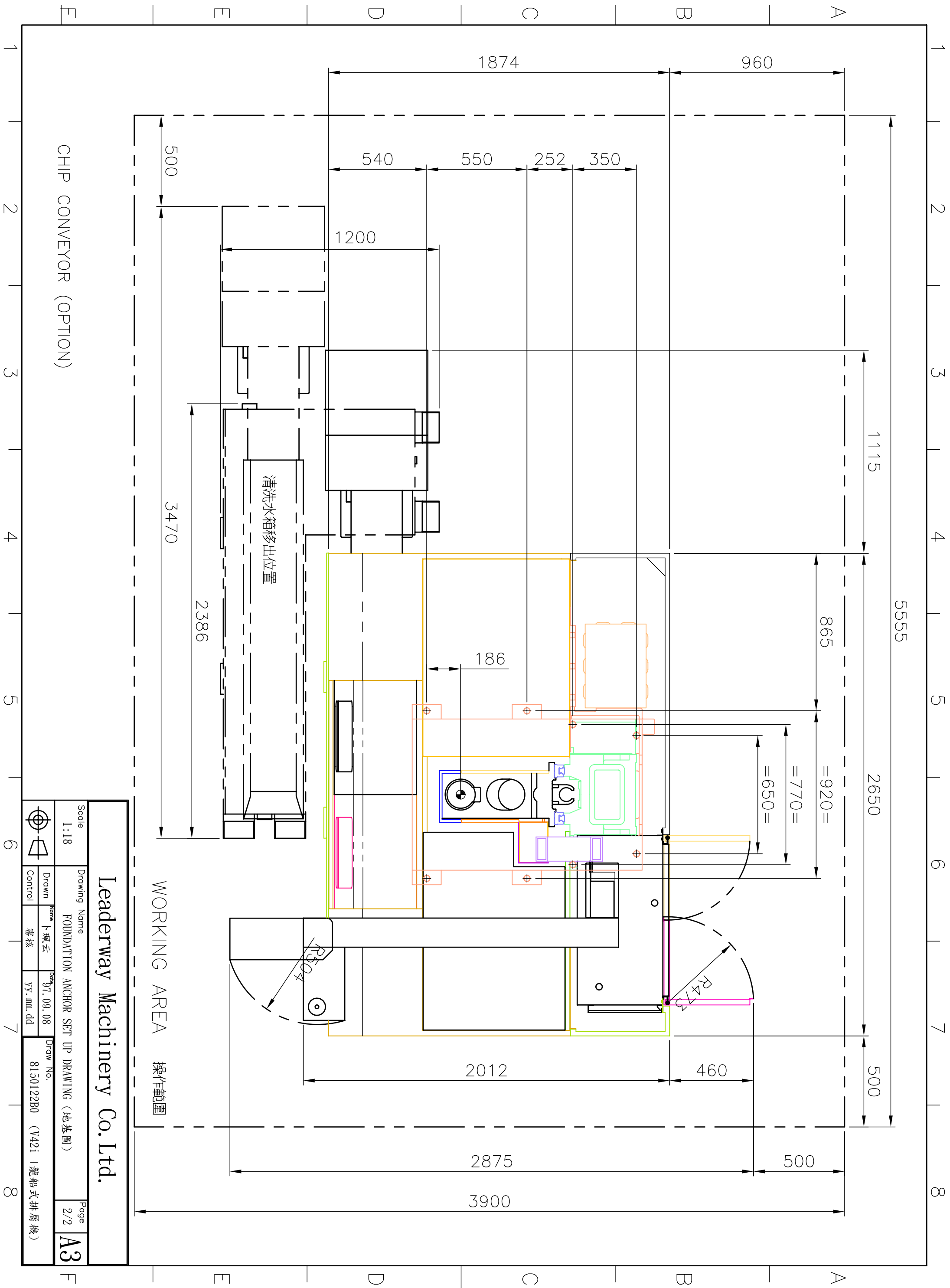

WORKING AREA
操作範圍

清洗水箱移出位置

Leaderway Machinery Co. Ltd.

Scale 1:18	Drawing Name FOUNDATION ANCHOR SET UP DRAWING (地基圖)			Page 2/2
Drawn Control	Name 卜佩云 審核	Date 97.09.08	Draw No. 8150122B0 (V421 + 龍船式排屑機)	A3

CHIP CONVEYOR (OPTION)

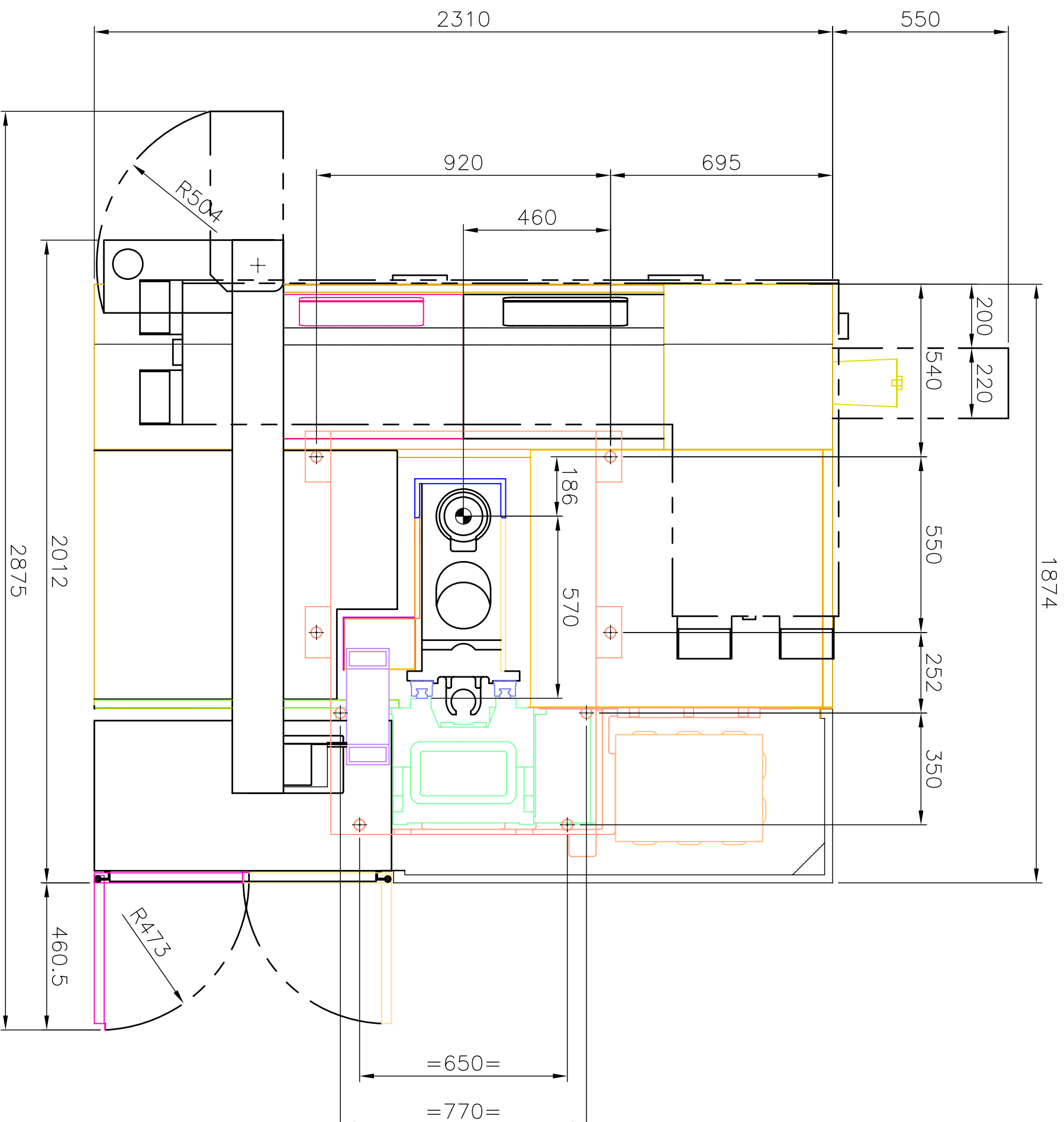

Leaderway Machinery Co. Ltd.

Scale		Drawing Name		Page	
1:14		OUTLINE DIMENSION (TOP VIEW) 外型尺寸圖		1/3	
Drawn		Date		Draw No.	
AMY		97.04.28		8150135B0 (V331)	
Control					

A3

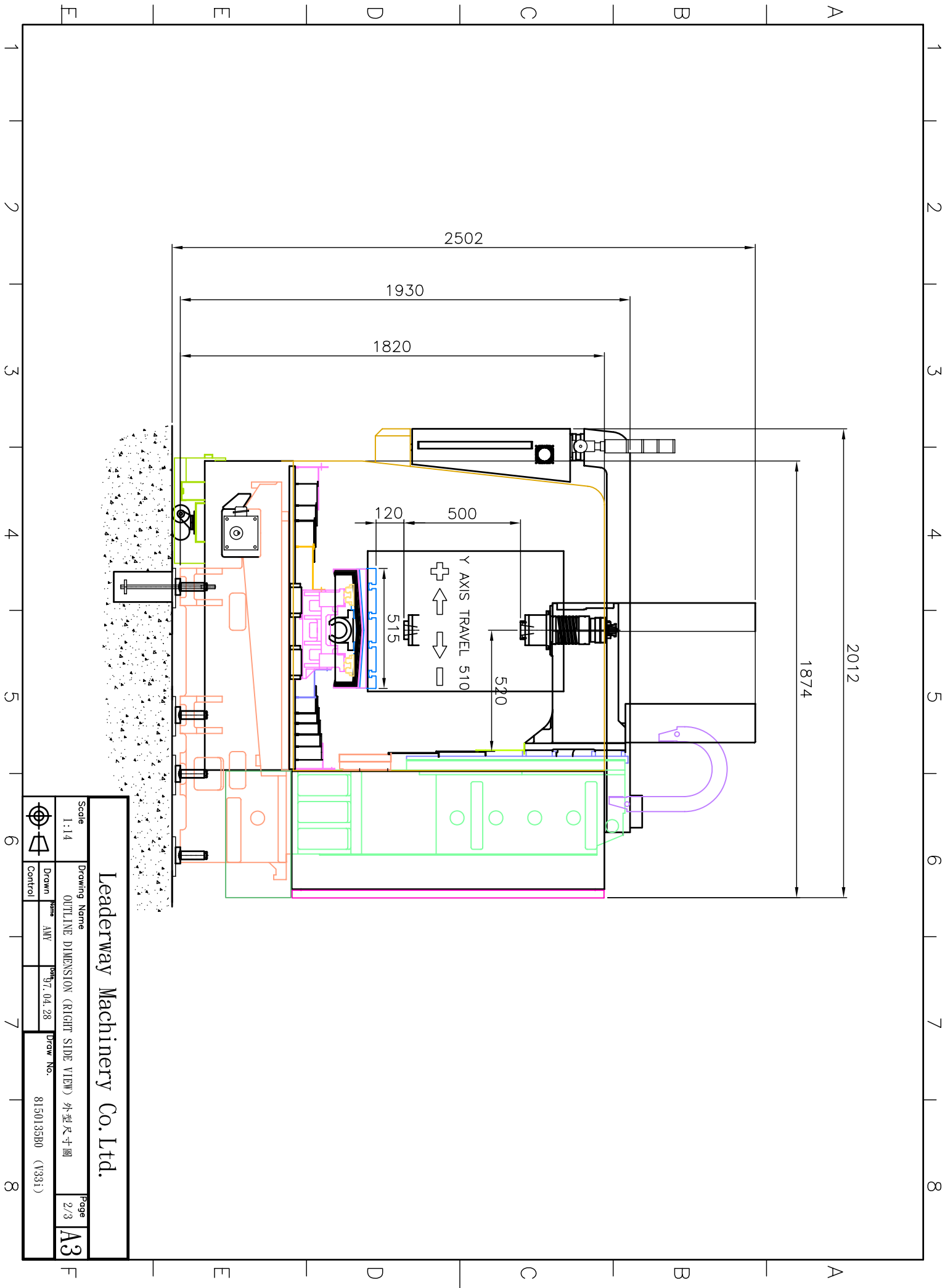

Leaderway Machinery Co. Ltd.

Scale	1:14			Page	2/3
Drawing Name	OUTLINE DIMENSION (RIGHT SIDE VIEW) 外型尺寸圖			Drawn	AMT
Drawn	AMT	Date	97.04.28	Draw No.	8150135180 (1331)
Control					

A3

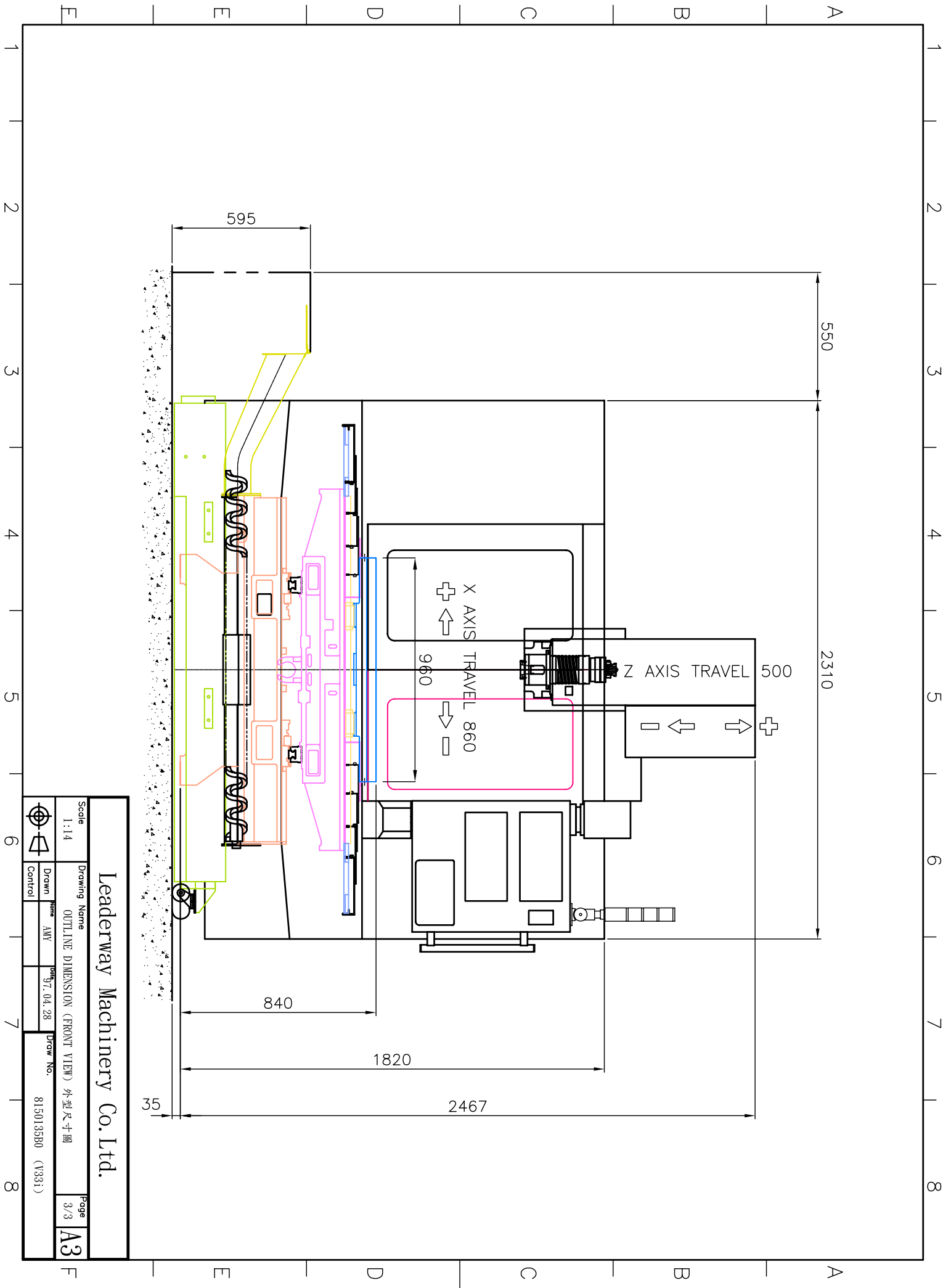

Leaderway Machinery Co. Ltd.

Scale	1:14		Drawing Name	OUTLINE DIMENSION (FRONT VIEW) 外型尺寸圖		Page	3/3
Drawn	AW	Design	7.04.28	Draw No.	815013530 (Y331)	A3	
Control							

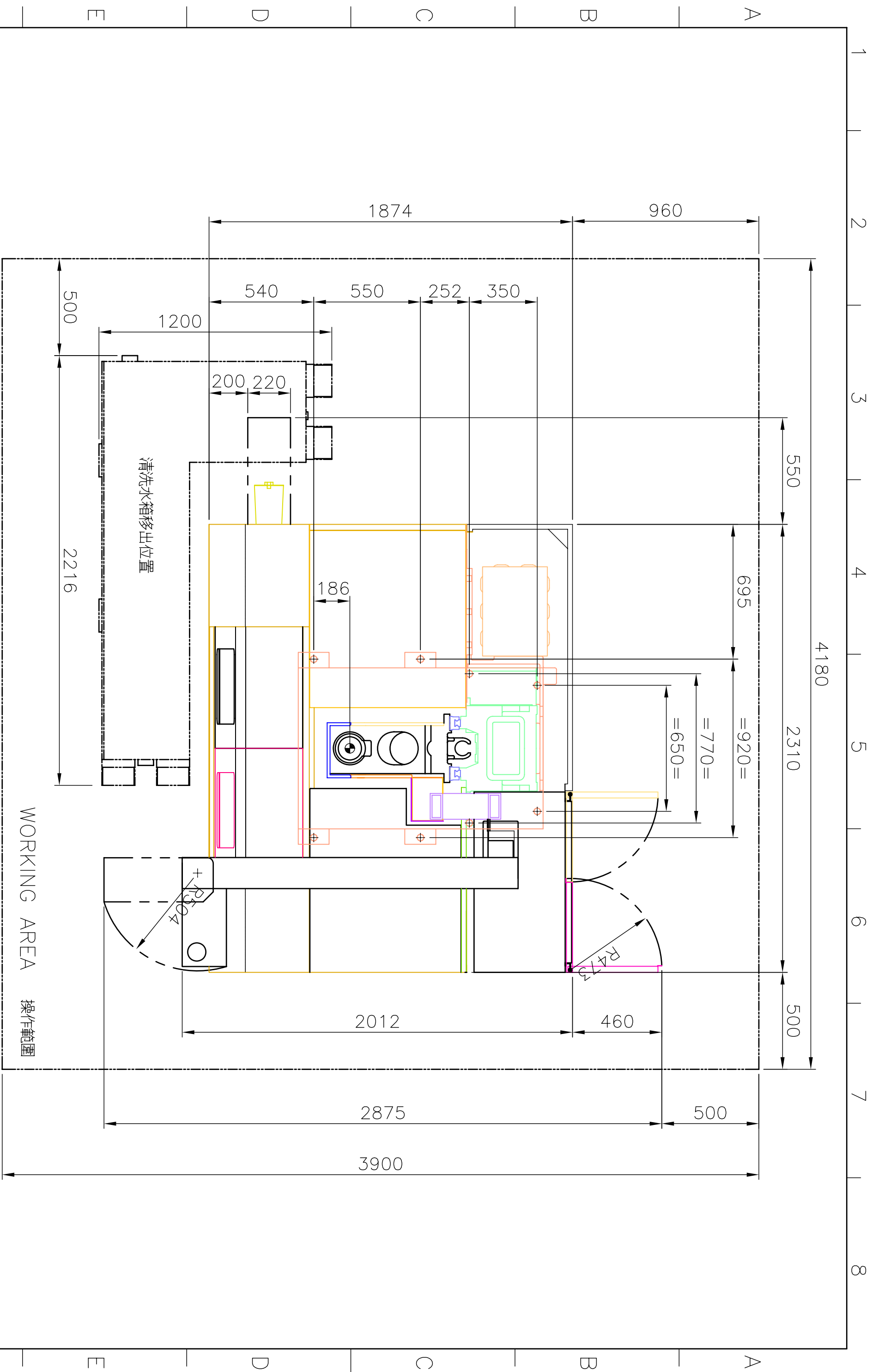

Leaderway Machinery Co. Ltd.

Scale 1:18	Drawing Name FOUNDATION ANCHOR SET UP DRAWING (地基圖)	Page 1/2
Drawn 卜珮云	Date 97.09.08	Draw No. 8150135B0 (V33i + 標準水箱)
Control 審核	yy.mm.dd	

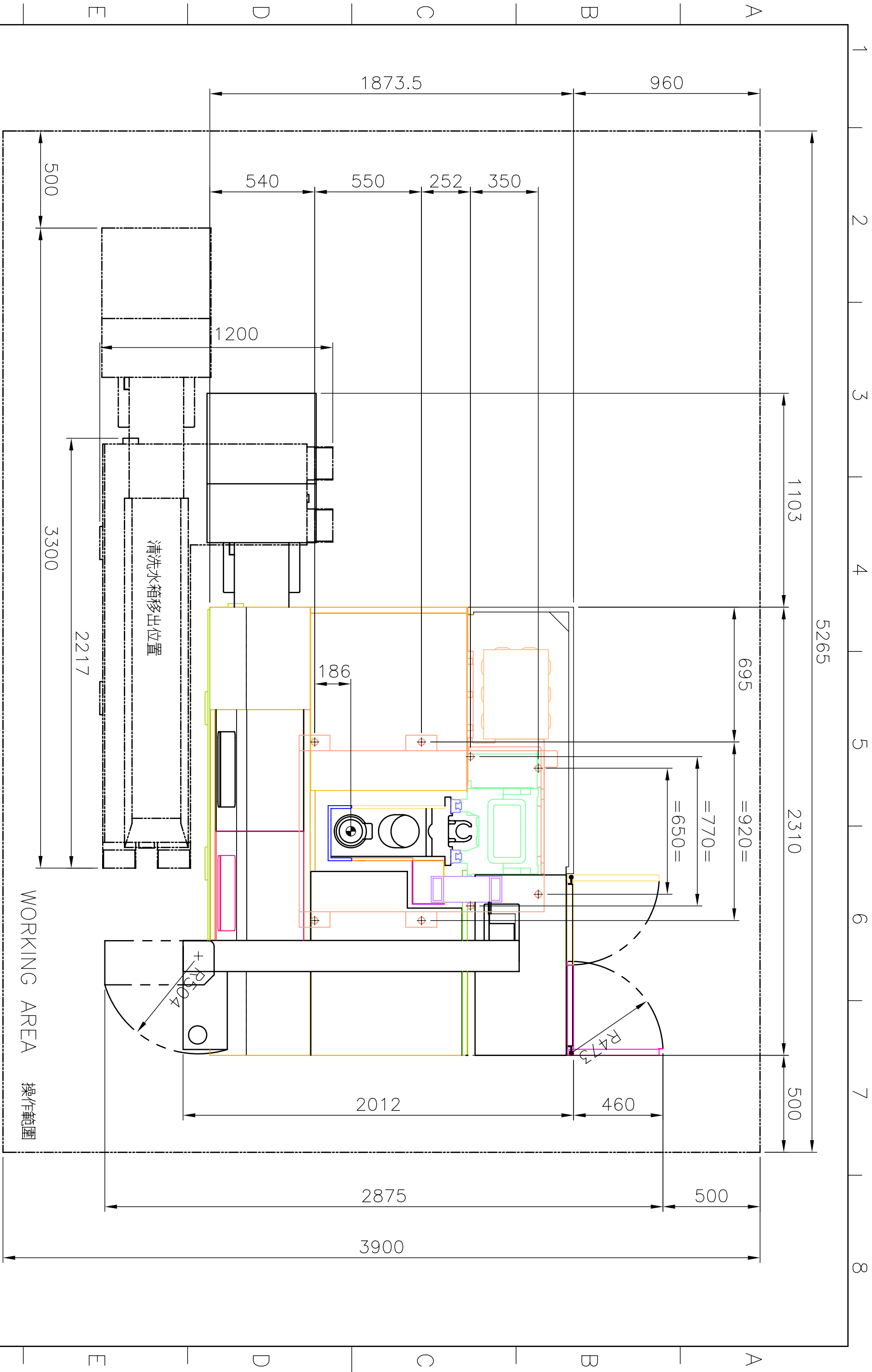

CHIP CONVEYOR (OPTION)

Leaderway Machinery Co. Ltd.

Scale	Drawing Name			Page
1:18	FOUNDATION ANCHOR SET UP DRAWING (地基圖)			2/2
Drawn	Name	Date	Draw No.	A3
Control	卜珮云	97.09.08	8150135B0	
	審核	yy.mmm.dd	(V33i + 龍船式排屑機)	

A=350(V450/V650(V650HSM)/V331/V421)
 A=500(V1100/MV1100S/MV1100D/MV1300D/LX8/LX10
 A=700(LX1600/LX2200)
 A=1000(LX-B.....)

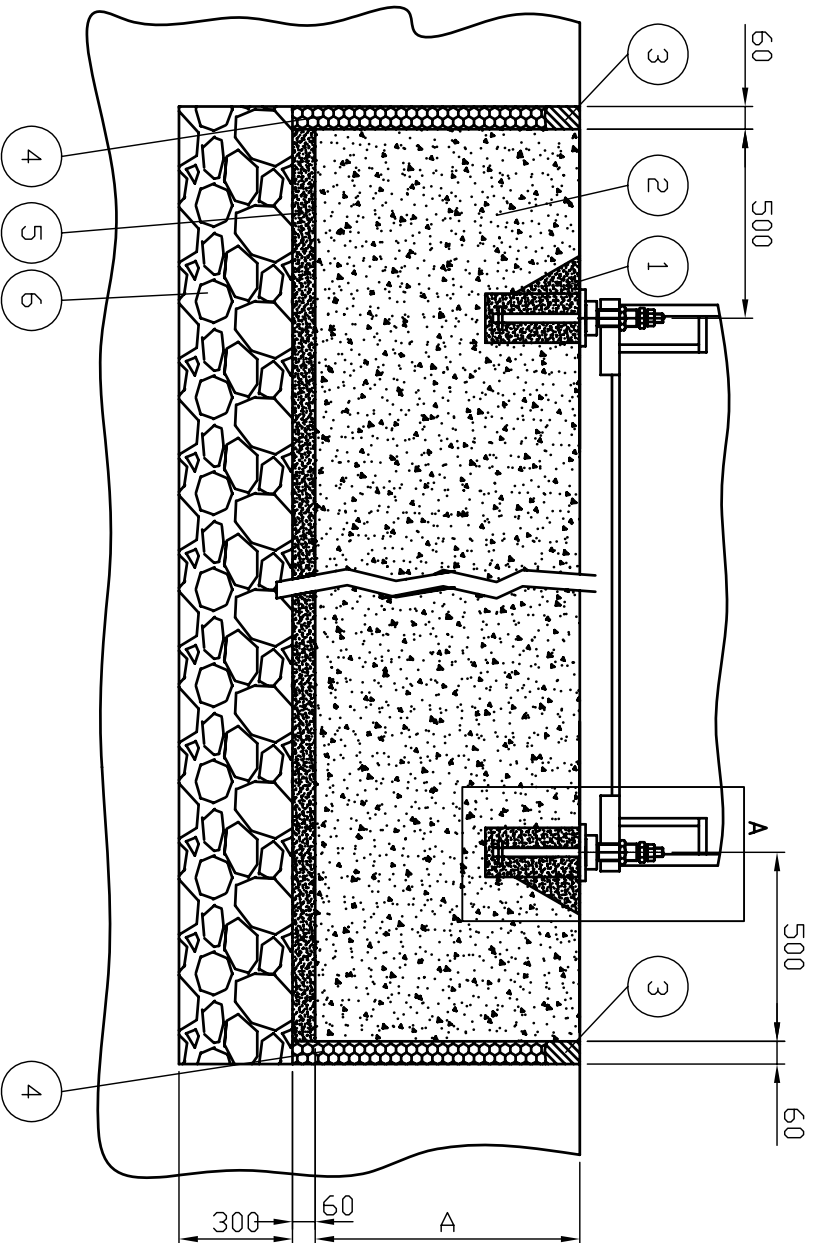

- 1) Concrete 5000pci
- 2) concrete 3000pci
- 3) Anti-oil/heat branze
- 4) Anti-vibration polyfoam
- 5) Anti-vibration sand
- 6) Round-shaps ston Dia. 150~300

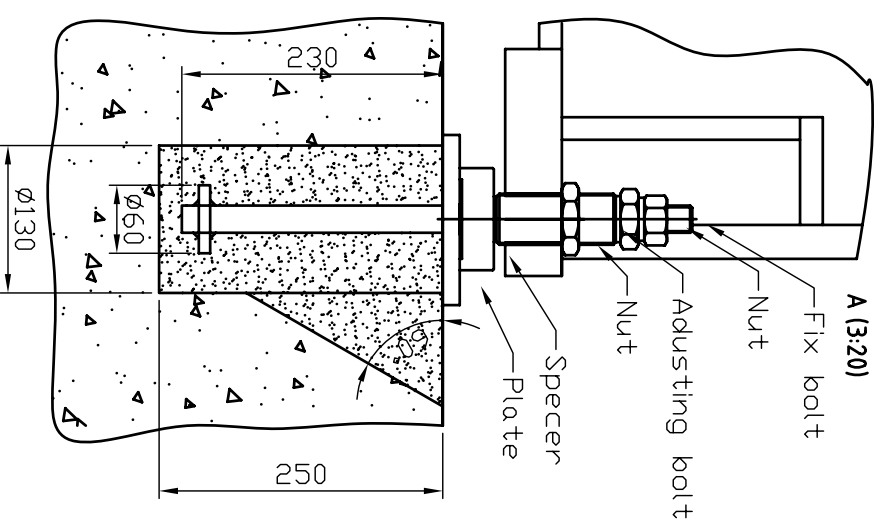
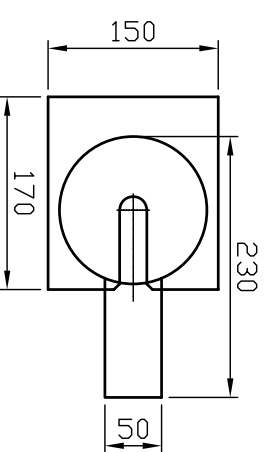

Leaderway Machinery Co. Ltd.

Scale
1:20

Drawing Name

PROCESS OF SETTING (地基施工圖)

Page

1/2
A4

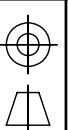

Drawn

Control

jack

jack

Date

96. 11. 20

Date

96. 11. 20

Draw No.

8150198B0 (全機型)

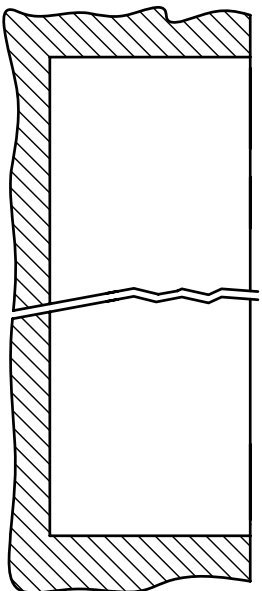

According to foundation drawing set the foundation area

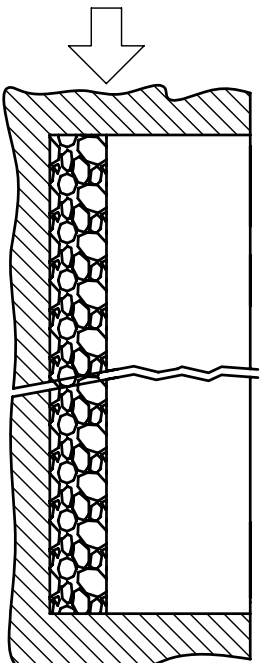

First, put stones on the bottom
stone dia 10mm~300mm

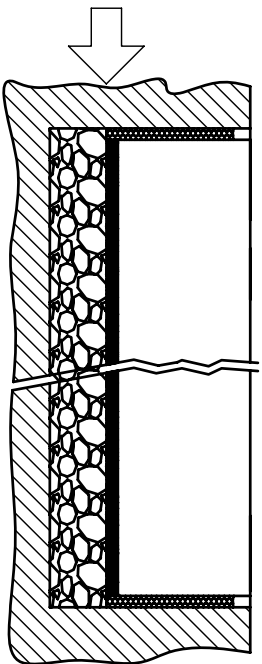

Fill up the sand and styrofoam plate on the other side

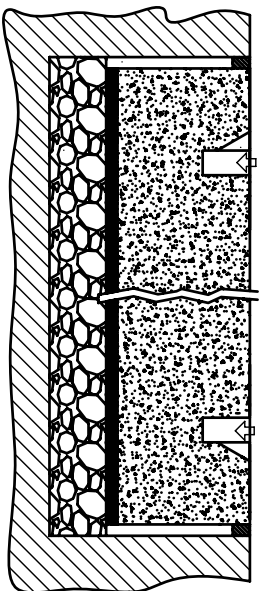

hoist machine higher and install the anchor bolts

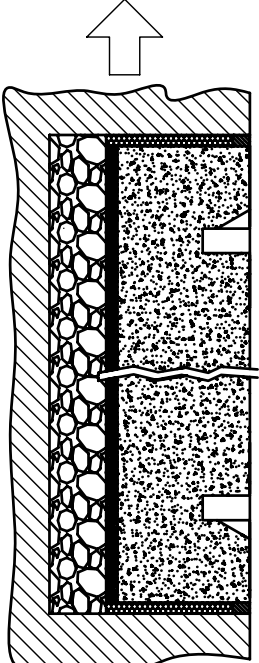

Dig out the hole of anchor bolts

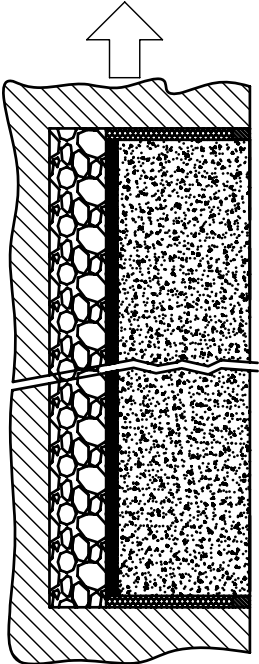

Put the oil-proof and anti-heat stripe on the other side, then fill up the cement(3000pci)
Harden time about 7~10 days

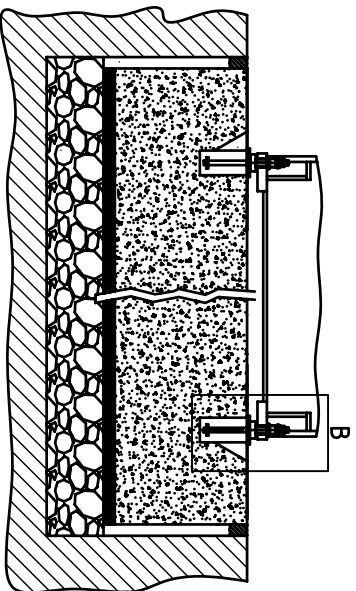

Put whole machine into the position

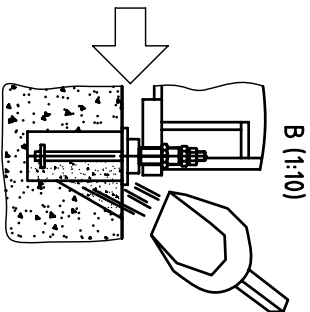

B (1:10)

Fill up with 5000pci cement
harden time about 3~5 days

Leaderway Machinery Co. Ltd.

Scale

1:20

Drawing Name

PROCESS OF SETTING (地基施工圖)

Page

2/2 A4



Drawn

jack

Control

Date

96. 11. 20

Date

96. 11. 20

Draw No.

8150198B0 (全機型)

6	High-Pressure oil hose	1	1/8"PT R1 610mm	
5	Automatic piston Lubricator	1	5 ports	
4	Automatic piston Lubricator	2	5 ports	
3	Equal tee	3	PKD-06(φ6)	
2	Flexible metal hose	1	φ6*600L	
1	Automatic piston Lubricator	1	CEVB-03/220V	
Item	Description	Q. ty	Standard	Material

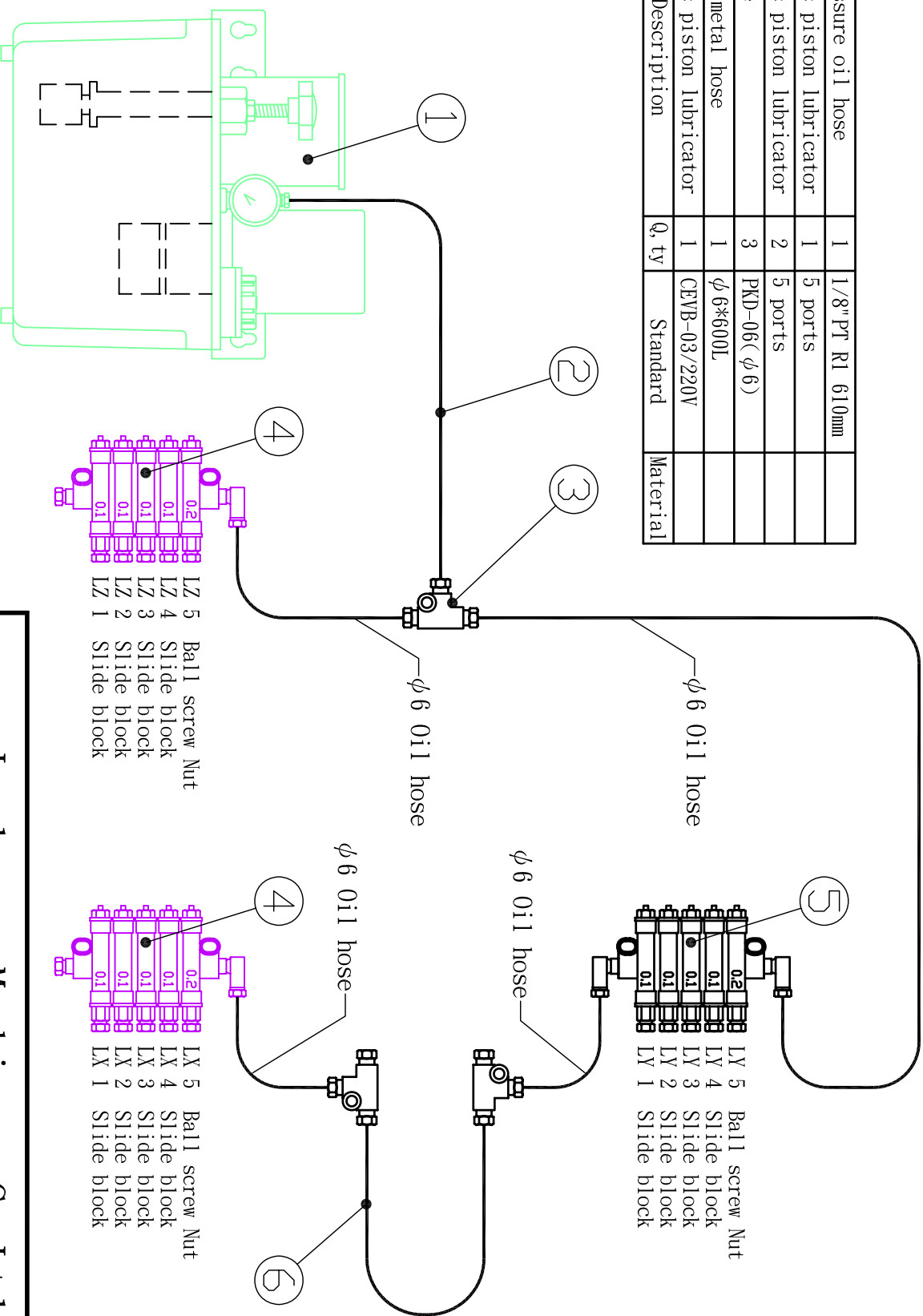

- LZ 5 Ball screw Nut
- LZ 4 Slide block
- LZ 3 Slide block
- LZ 2 Slide block
- LZ 1 Slide block

- LX 5 Ball screw Nut
- LX 4 Slide block
- LX 3 Slide block
- LX 2 Slide block
- LX 1 Slide block

Leaderway Machinery Co. Ltd.

Suitable Type:
V-450/V-650/V-33i/V-1100

Scale 1:4	Drawing Name 潤滑油路配件組合圖 LUBRICATION ASSEMBLY DIAGRAM	Page 1/1
Drawn 張靜宜	Date 97.06.05	Draw No. 8150106B0
Control		

6	High-Pressure oil hose	1	1/8"PT R1 610mm	
5	Automatic piston Lubricator	1	7 ports	
4	Automatic piston Lubricator	2	5 ports	
3	Equal tee	3	PKD-06(φ6)	
2	Flexible metal hose	1	φ6*600L	
1	Automatic piston Lubricator	1	CEVB-03/220V	
Item	Description	Q. ty	Standard	Material

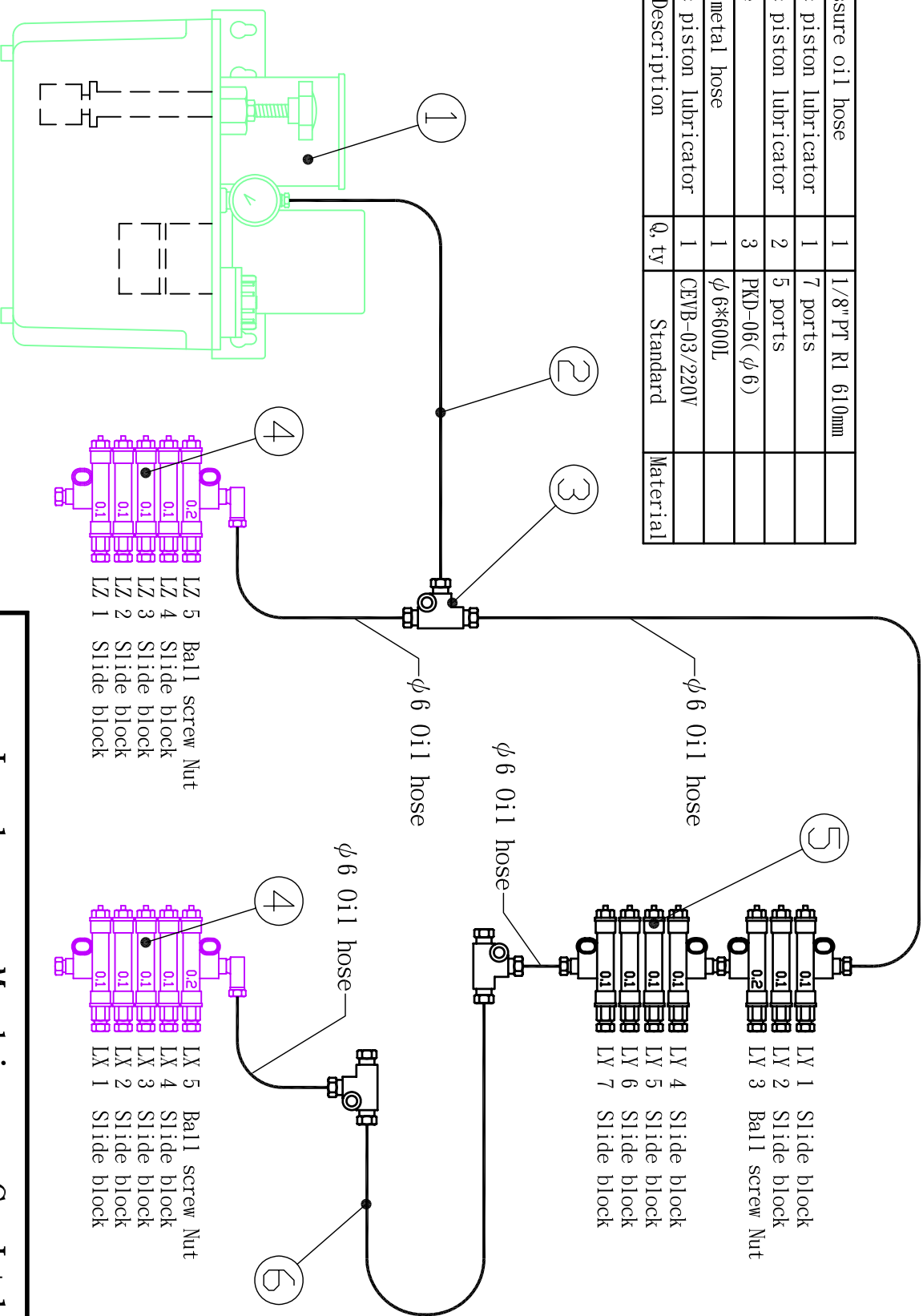

- LZ 5 Ball screw Nut
- LZ 4 Slide block
- LZ 3 Slide block
- LZ 2 Slide block
- LZ 1 Slide block

- LX 5 Ball screw Nut
- LX 4 Slide block
- LX 3 Slide block
- LX 2 Slide block
- LX 1 Slide block

- LY 1 Slide block
- LY 2 Slide block
- LY 3 Ball screw Nut
- LY 4 Slide block
- LY 5 Slide block
- LY 6 Slide block
- LY 7 Slide block

Suitable Type:
V-42i

Leaderway Machinery Co. Ltd.

Scale 1:4	Drawing Name 潤滑油路配件組合圖 LUBRICATION ASSEMBLY DIAGRAM	Page 1/1
Drawn 張靜宜	Date 98.01.13	Draw No. 8150039B0
Control		

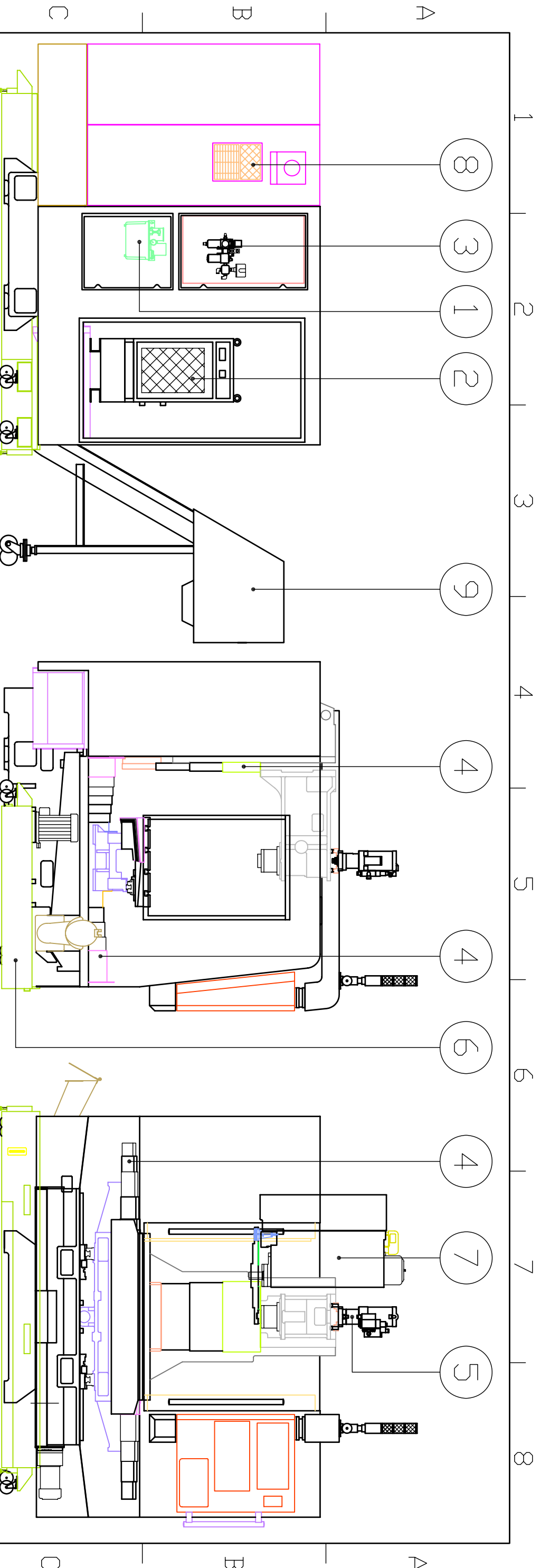

DAILY MAINTENANCE	1			2			3			4			5			6			7			8			9			10			11		
	OPERATING HOURS	LUBRICATION UNIT	REFRIGERATION UNIT	AIR TREATMENT UNIT	TELESCOPIC COVER	FIGHTING KNIFE DEVICE	COOLING UNIT	TOOL MAGAZIN	HEAT EXCHANGER	CHIP CONVEYOR	GEAR BOX	HYDRAULIC UNIT	POINT N°	MAINTENANCE SYMBOL	MACHINE COMPONENT	POINT N°	MAINTENANCE SYMBOL	MACHINE COMPONENT	POINT N°	MAINTENANCE SYMBOL	MACHINE COMPONENT	POINT N°	MAINTENANCE SYMBOL	MACHINE COMPONENT	POINT N°	MAINTENANCE SYMBOL	MACHINE COMPONENT	POINT N°	MAINTENANCE SYMBOL	MACHINE COMPONENT			
CHECK ITEMS	1	2	3	1	2	3	1	2	3	1	2	3	1	2	3	1	2	3	1	2	3	1	2	3	1	2	3	1	2	3			
MANUALLY LUBRICATION	8		8																														
CHECK																																	
CHANGE																																	
CLEAN AND LUBRICATE																																	
CHECK AND FILL		8		200				40																									
DRAIN AND REFILL									2000																								
TYPE OF LUBRICANT (STANDARD ISO 3498)		VG-68		VG-22			VG-22		VG-68			VG-32																					

ATTENTION: CLEAN ALL THESE POINTS THOROUGHLY BEFORE LUBRICATION

Ⓜ MOBILCUT 232-CONCENTRATION 7% MAXI. (PLEASE REFER TO END USER'S SUPPLIER MANUAL)

The machine part accessories listed above does not exactly accord with your sales order. Please refer to your sales order if any machine parts accessories differences.

Leaderway Machinery Co. Ltd.

Scale	1:23	Drawing Name	V-33i/V-42i 每日保養表	Page	1/1
			V-33i/V-42i THE SKETCH OF DAILY MAINTENANCE		A3
Drawn	卜根云	Date	99.03.18	Draw No.	8150047C0
Control					

1 2 3 4 5 6 7 8

A B C D E F

97/12

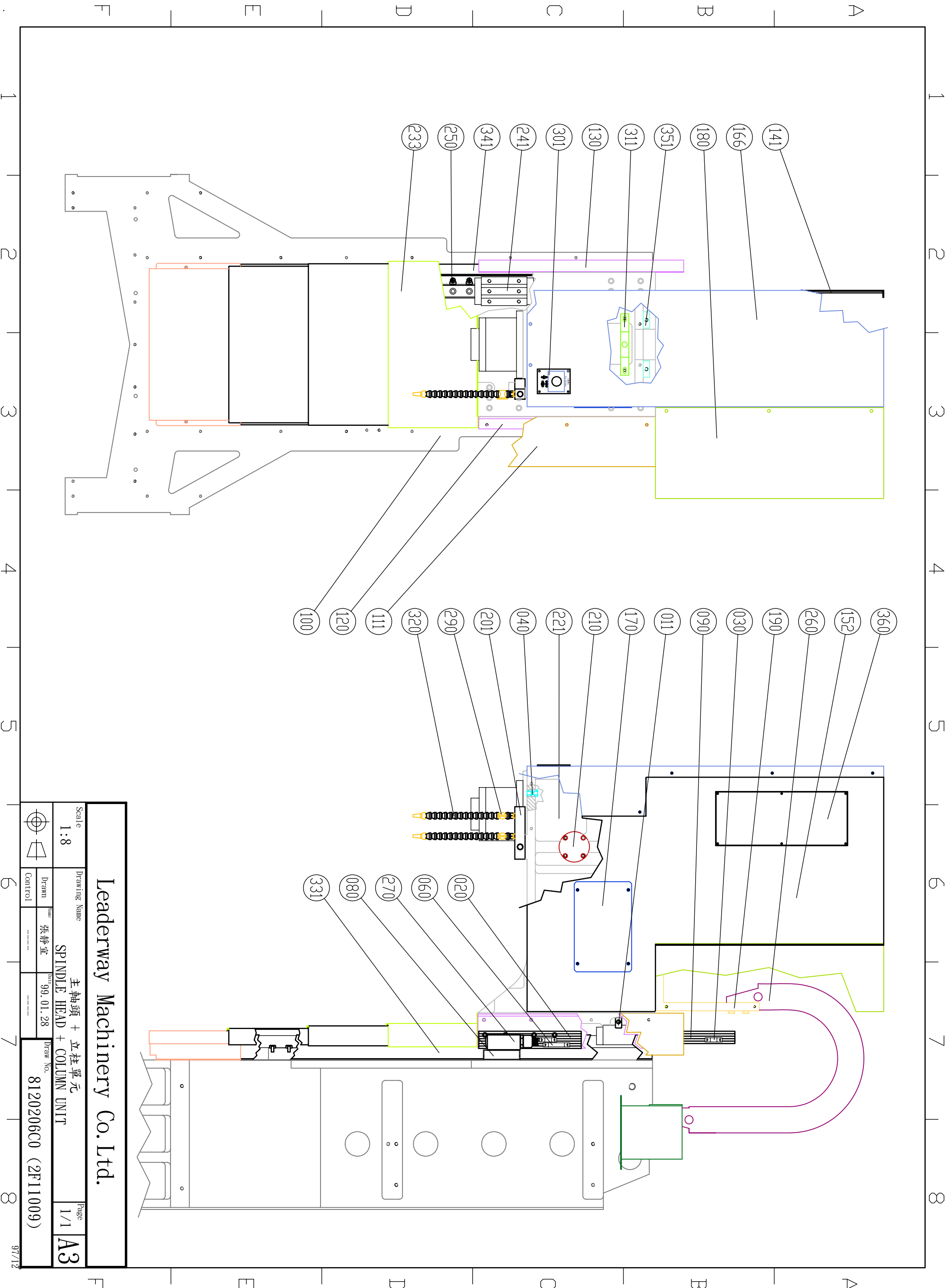

Leaderway Machinery Co. Ltd.

Scale 1:8		Drawing Name 主軸頭 + 立柱單元 SPINDLE HEAD + COLUMN UNIT		Page 1/1	
Drawn 張靜宜	Date 99.01.28	Draw No. 8120206C0 (2F11009)	Control	97/12	

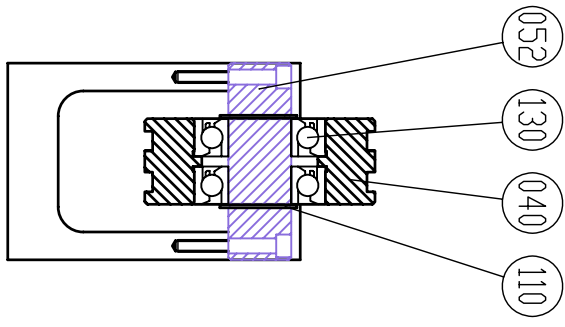
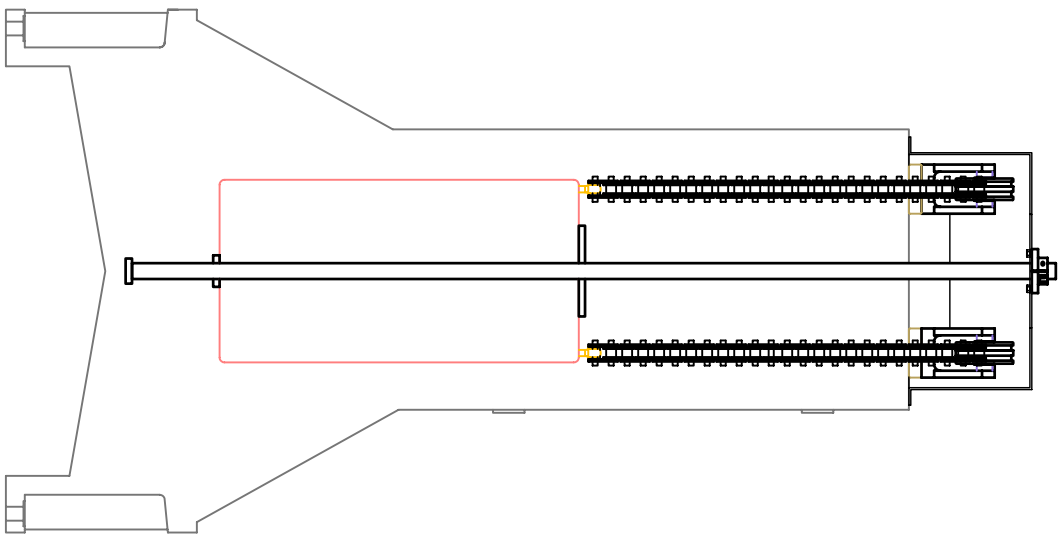

比例 1:3

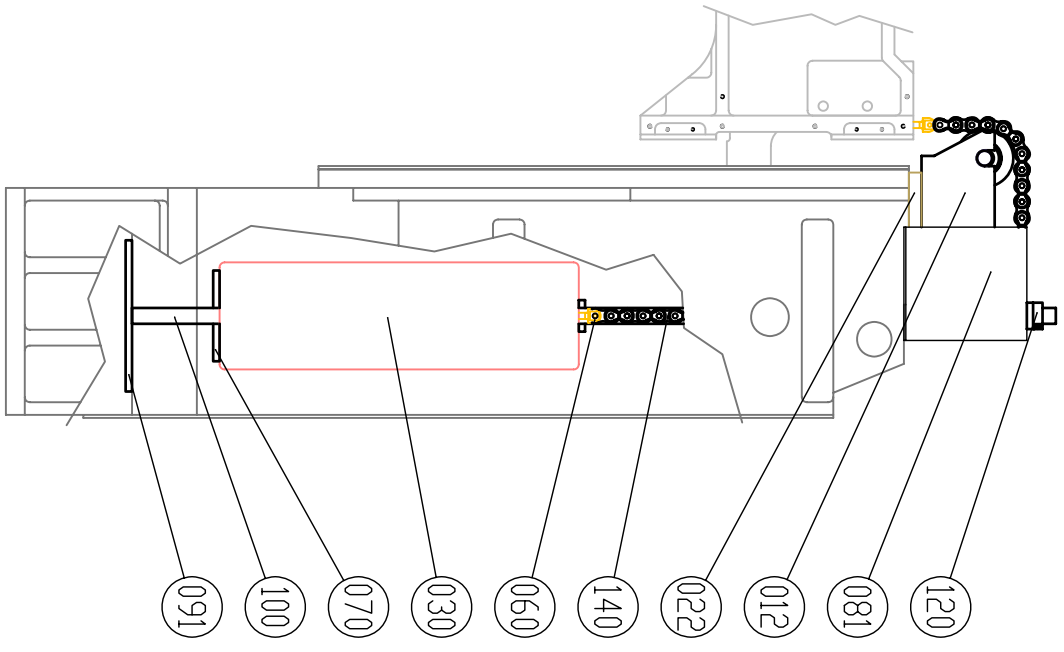

Leaderway Machinery Co. Ltd.

Scale 1:12	Drawing Name V-33i/V-42i 配重單元 V-33i/V-42i COUNTER BALANCE UNIT	Page 1/1
Drawn 張靜宜	Date 97.11.07	Draw No. 8120275B0 (2F16005)
Control		



A4

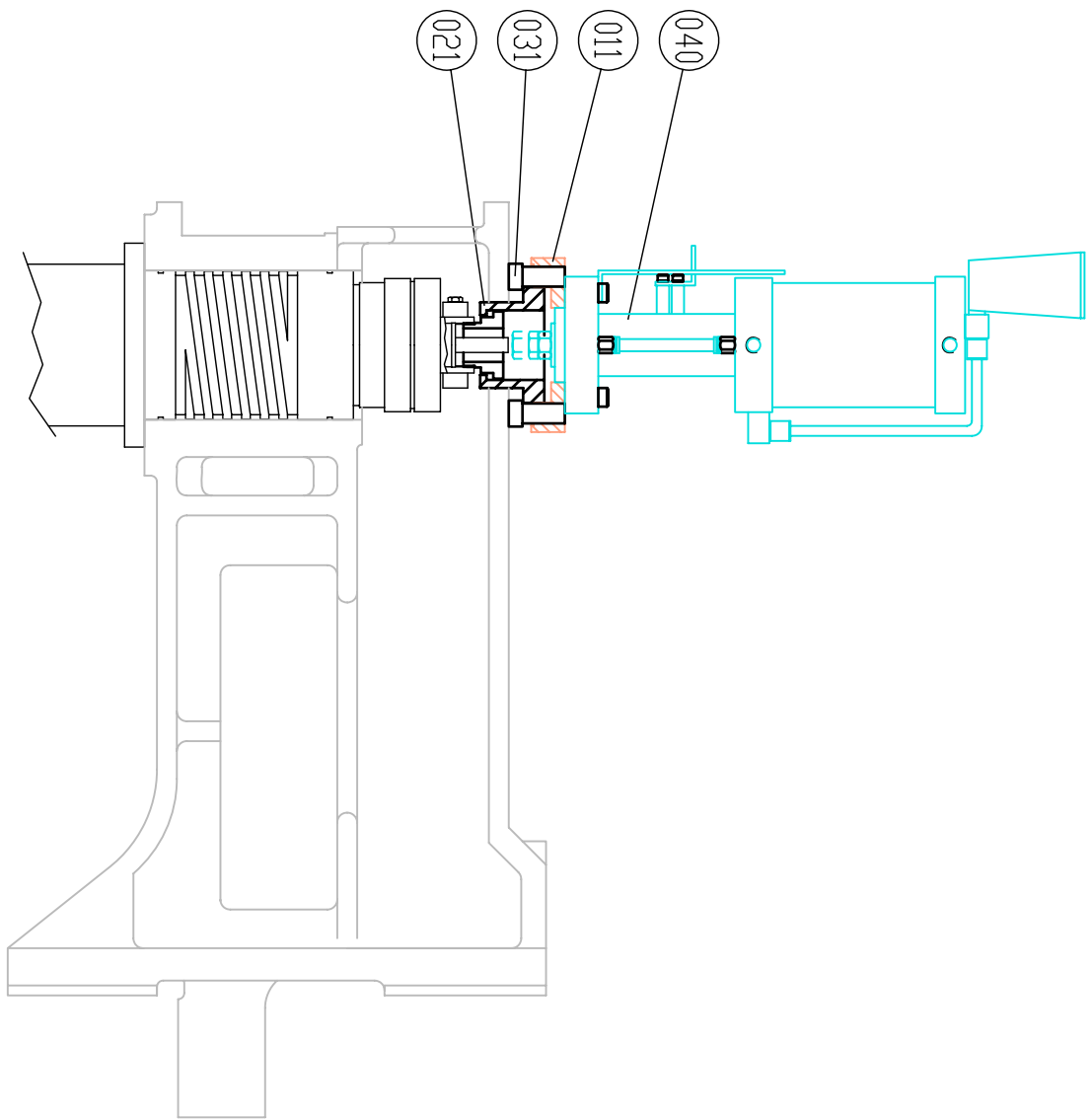
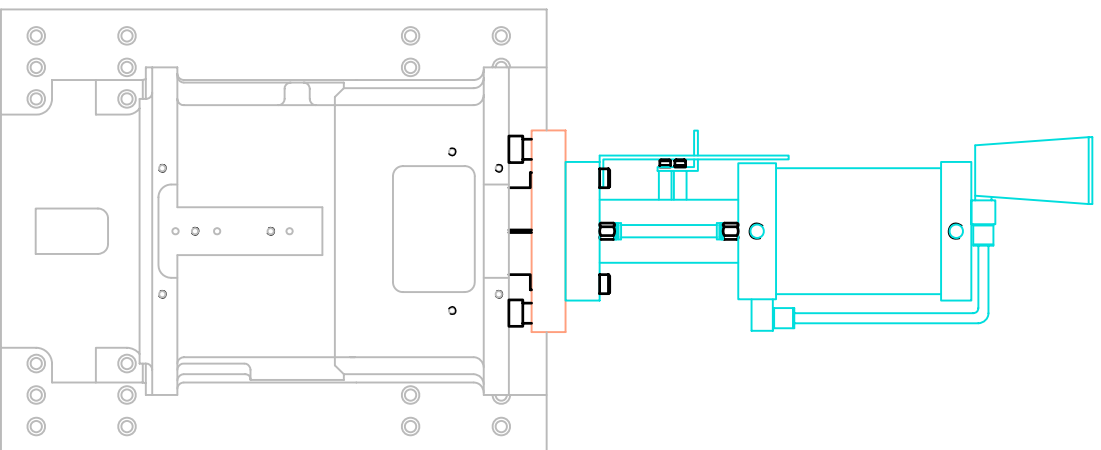

Leaderway Machinery Co. Ltd.

Scale		Drawing Name		Page	
1:6		打刀單元 BOSSING CYLINDER UNIT		1/1	
Drawn		Date		A4	
Control		97.11.07		8120207B0 (2F27004)	
張靜宜		Draw No.			

台灣力得衛宇龍科技股份有限公司

*單階材料用量清單

製表日期: 099-09-08

第1頁

主件品號	序號	元件品號	品名 英文品名	規 格	用量
2F11009			主軸頭+立柱單元 SPINDLE HEAD + COLUMN UNIT	V860/V33i/V42i	
	0011	3500012B0	滑座壓塊 SLIDING BLOCK,ADJUSTABLE BRA	3210\SS41	4
	0020	3500014B0	碰塊座 DOG BRACKET	4140\AL(250m/m*3軌)	1
	0030	3500081A0	碰塊 DOG	3140\SS41(42m/m)	2
	0040	3500306A0	管接頭座 CONNECTOR BRACKET	3150\S45C	1
	0060	3540007A0	碰塊 DOG	4140\AL 外購65L	1
	0080	3580047B0	微動開關座(Z軸) MICRO SWITCH BRACKET, Z AXIS	7160\SPCC	1
	0090	3580048A0	碰塊座 DOG BRACKET	4140\AL(200m/m*2軌)	1
	0100	3580116D0	立柱 COLUMN	1020\FC-25\3580001B2	1
	0111	3581001C0	碰塊座蓋板 DOG BRACKET COVER	7210\SPCC	1
	0120	3581002B0	碰塊座固定板 FIXED PLATE, DOG BRACKET	7210\SPCC	1
	0130	3581003A0	主軸頭左後側蓋板 (L)REAR COVER, SPINDLE HEAD	7510\SPCC	1
	0141	3581004C0	主軸頭左側蓋板 LEFT COVER, SPINDLE HEAD	7510\SPCC	1
	0152	3581005E0	主軸頭右側蓋板 RIGHT COVER, SPINDLE HEAD	7510\SPCC	1
	0166	3581006I0	主軸頭前蓋 FRONT COVER,SPINDLE HEAD	7510\SPCC	1
	0170	3581007A0	封蓋 HOLE COVER	7180\SPCC	1
	0180	3581008B0	前支架蓋板 COVER FOR FRONT BRACKET	7210\SPCC	1
	0190	3581009C0	連動管前支架 FRONT BRACKET, CONDUIT	7210\SPCC	1
	0201	3581010C0	噴水管座 NOZZLE TUBE BRACKET	3150\SS41	1
	0210	3581011A0	孔蓋 HOLE CAP	3230\S45C	2
	0221	3581012F0	主軸頭 SPINDLE HEAD	1010\FC-25\3581000D2	1
	0233	3581020E0	Z軸下摺動罩 LOWER TELESCOPIC COVER, Z	7400\SPCCZ	1
	0241	3985014B0	線性滑軌(滾柱型) LINEAR GUIDE(CYLINDRIC ROLLE	9840	1
	0250	4080106015	直銷(軸承鋼針) PIN	φ 6x15L	50
	0260	4640065133	方型聯動管 WIRE CONDUIT	KY-CE(CBS65.2)-65x133-(22目)	1
	0270	4800143204	微動開關 MICRO SWITCH	BNS819-B02-D12-61-12-10BALLU	1
	0290	4250101414	球閥內外牙 BALL VALVE	1/4"	2
	0301	3990144A0	刀具釋放指示牌 NAME PLATE	4350\AL	1
	0311	3500063B0	近接開關座 PROXIMITY SWITCH BRACKET	7160\SPCC	1
	0320	4210114016	噴水管 NOZZLE TUBE	1/4"轉接頭*軟管x16*1/4"噴嘴	2
	0331	3581248B0	立柱右飾板 COLUMN PLATE	7510\SPCC	1

<續下頁>

台灣力得衛宇龍科技股份有限公司

*單階材料用量清單

製表日期: 099-09-08

第2頁

主件品號	序號	元件品號	品名 英文品名	規 格	月量
2F11009	0341	3581249B0	立柱左飾板 COLUMN PLATE	7510\SPCC	1
	0351	3500010B0	調整檔塊 ADJUSTABLE STOPPER	3140\SS41	2
	0360	3580279A0	機頭側壓克力 ACRYLIC PLATE, SPINDLE HEAD	4360\ACRY	1

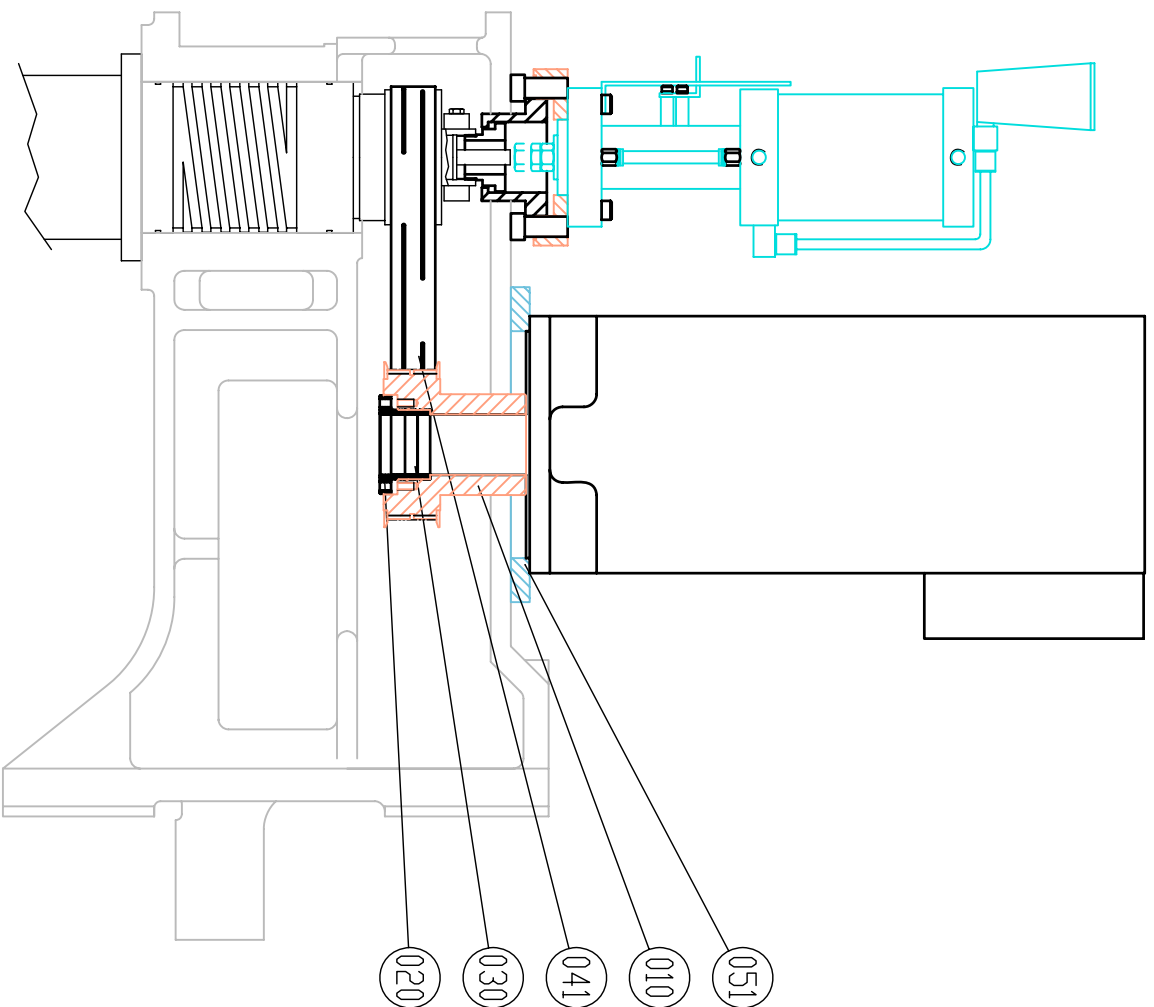

Leaderway Machinery Co. Ltd.

Scale		Drawing Name		Page	
1:6		主軸皮帶輪單元 (FANUC α8) SPINDLE BELT UNIT (FANUC α8)		1/1	
Drawn		Date		A4	
Control		97.11.10		8120006B0 (2F28011)	
張靜宜		Draw No.			

台灣力得衛宇龍科技股份有限公司

*單階材料用量清單

製表日期: 099-09-08

第1頁

主作品號	序號	元作品號	品名 英文品名	規 格	月量
2F16005			配重單元 COUNTER BALANCE UNIT	V33i/V42i	
	0012	3500006C0	鏈輪軸固定座 SPROCKET SHAFT BRACKET	1210\FC-25\3500006A2	2
	0022	3581230C0	鏈輪軸固定座墊塊 PAD OF SPROCKET SHAFT BRACKET	3180\S45C	2
	0030	3500424B0	配重 COUNTER BALANCE	3070\SS41\3500424B2	1
	0040	3500021A0	鏈條滾輪 ROLLER	3260\S45C	4
	0052	3500022C0	鏈輪軸 SHAFT SPROCKET	3260\S45C	4
	0060	3500023A0	鏈條連結螺絲 CHAIN CONNECTING BOLT	4310\SCM4	4
	0070	3500416A0	配重滑塊 SLIDING BLOCK,COUNTER BALANCE	4370\MC	2
	0081	3581231B0	滑軸固定座 FIXED BRACKET	7210\SPCC	1
	0091	3500418B0	滑軌下固定板 LOWER FIXED PLATE, GUIDING R	7180\SPCC	1
	0100	3500419B0	配重導桿 GUIDING ROD, COUNTER BALANCE	4290\圓棒	1
	0110	4060700025	C型扣環(軸用) C TYPE RETAINER RING	S-25	8
	0120	4062006025	軸心固定座 SHAFT BRACKET	SHF25-M6	1
	0130	4400206205	深槽滾珠軸承 BEARING	6205ZZ	8
	0140	4610050067	鏈條 CHAIN	50x67P (含2鏈目)	2

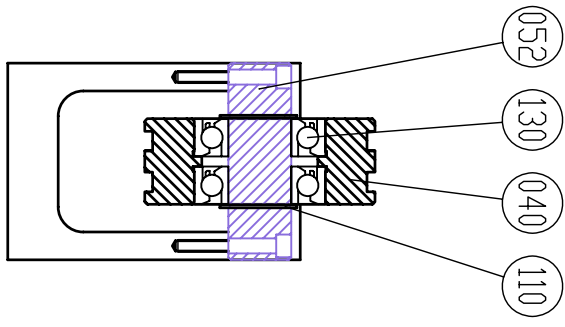
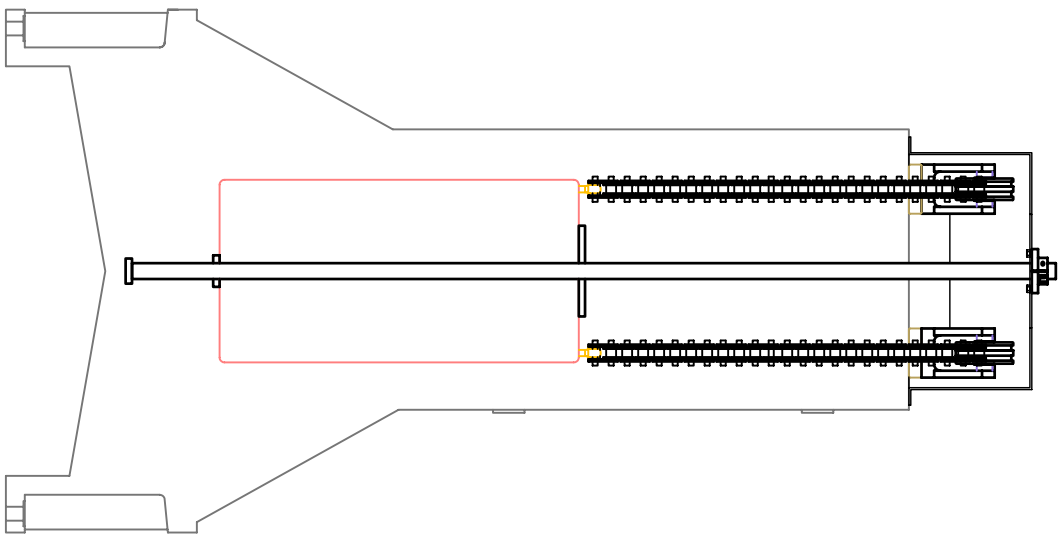

比例 1:3

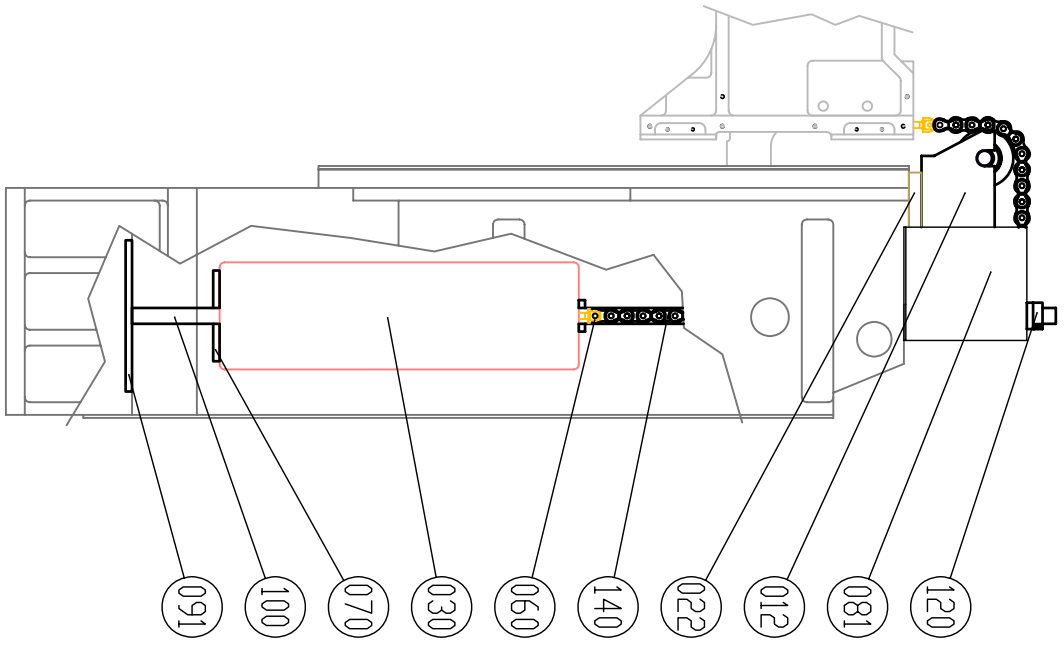

Leaderway Machinery Co. Ltd.

Scale 1:12	Drawing Name V-33i/V-42i 配重單元 V-33i/V-42i COUNTER BALANCE UNIT	Page 1/1
Drawn 張靜宜	Date 97.11.07	Draw No. 8120275B0 (2F16005)
Control		



A4

台灣力得衛宇龍科技股份有限公司

*單階材料用量清單

製表日期: 099-09-08

第1頁

主件品號	序號	元件品號	品名 英文品名	規 格	月量
2F27004			打刀單元 BOSSTING CYLINDER UNIT	V450/V33i/V42i	
	0011	3500008B0	增壓缸固定座 TOOL RELEASE CYLINDER BRACKE	3180\SS41	1
	0021	3500009B0	浮動打刀拉座 TOOL RELEASE CYLINDER SEAT	3250\S45C	1
	0031	3500019B0	固定軸套 FIXED ROD	3290\S45C	4
	0040	3980001A0	增壓缸(3Tx13L) TOOL RELEASE CYLINDER	9880	1

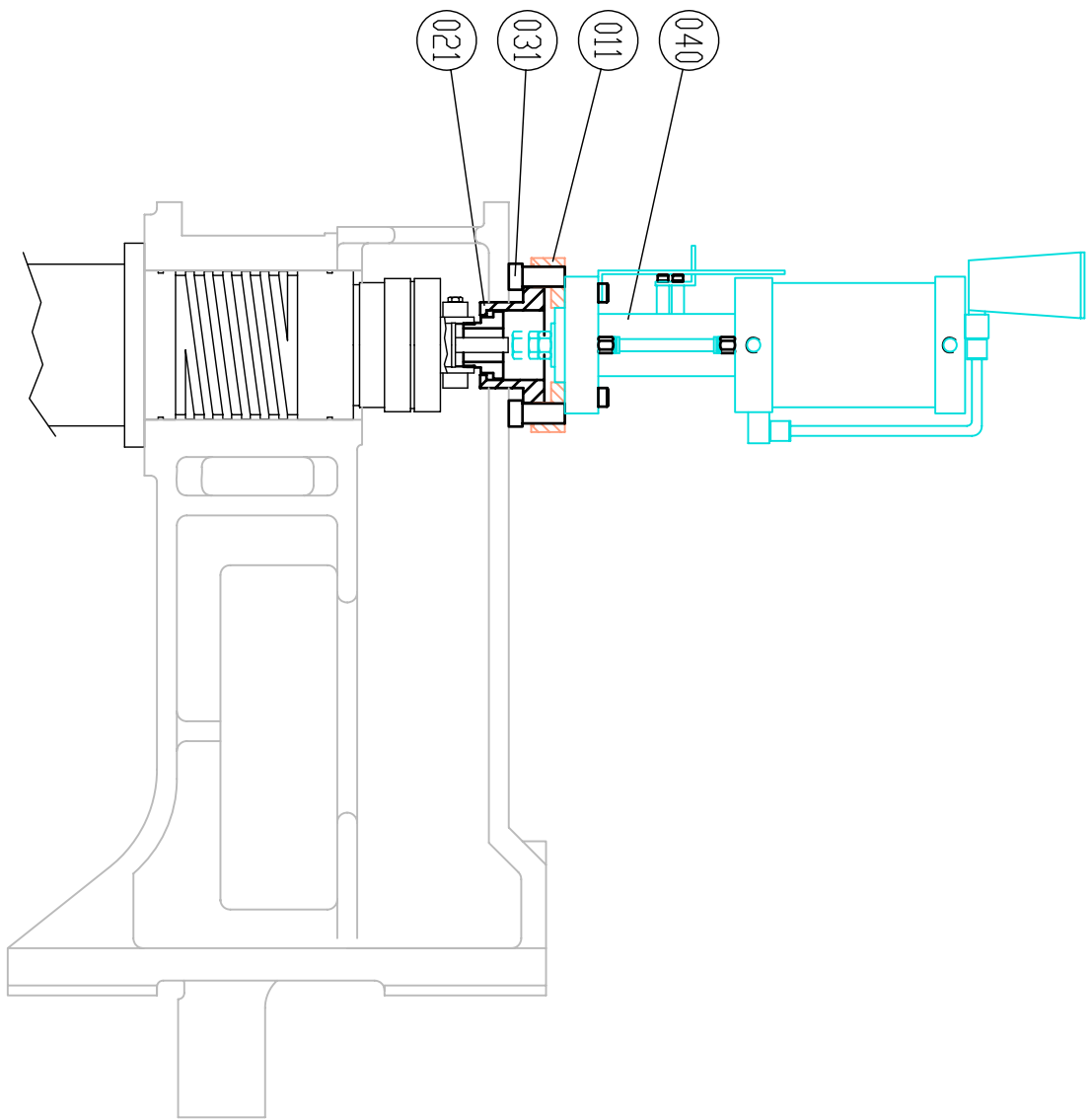
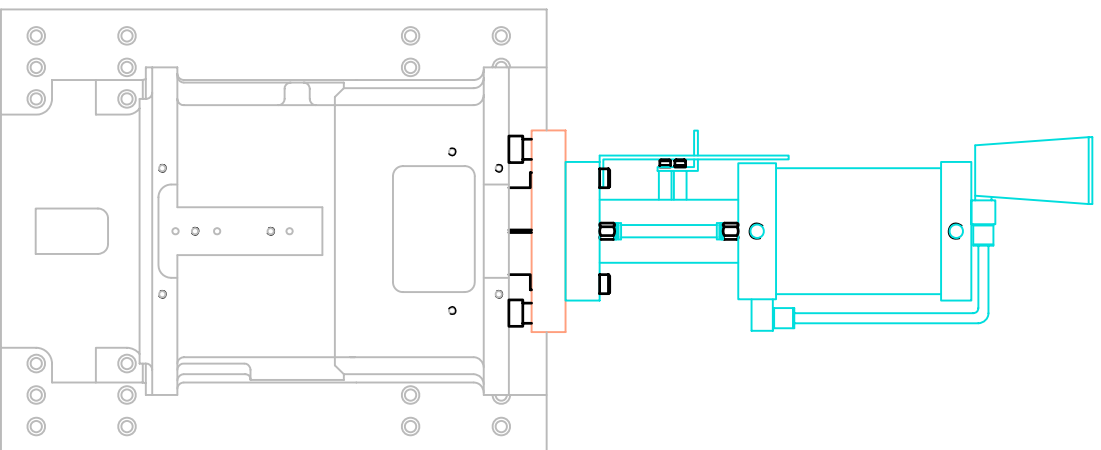

Leaderway Machinery Co. Ltd.

Scale		Drawing Name		Page	
1:6		打刀單元 BOSSING CYLINDER UNIT		1/1	
Drawn		Date		Draw No.	
Control		97.11.07		8120207B0 (2F27004)	
張靜宜					



台灣力得衛宇龍科技股份有限公司

*單階材料用量清單

製表日期: 099-09-08

第1頁

主件品號	序號	元件品號	品名 英文品名	規 格	月量
2F28008			主軸皮帶輪單元 SPINDLE BELT UNIT	V450/V33i/V42i F β8	
	0010	3971008A0	齒型皮帶輪(5GT-75T) PULLEY	3270\S45C	1
	0021	4601035810	齒型皮帶(剖溝) PULLEY BELT	5GT*35*810	1
	0030	3580161A0	馬達軸端蓋 SHAFT END COVER	3170\S45C	1
	0040	4061232036	迫緊環 PACKING RING	TLK300 32x36	2
	0051	3500011B0	主軸馬達固定板 FIXED PLATE FOR MOTOR	3170\SS41	1

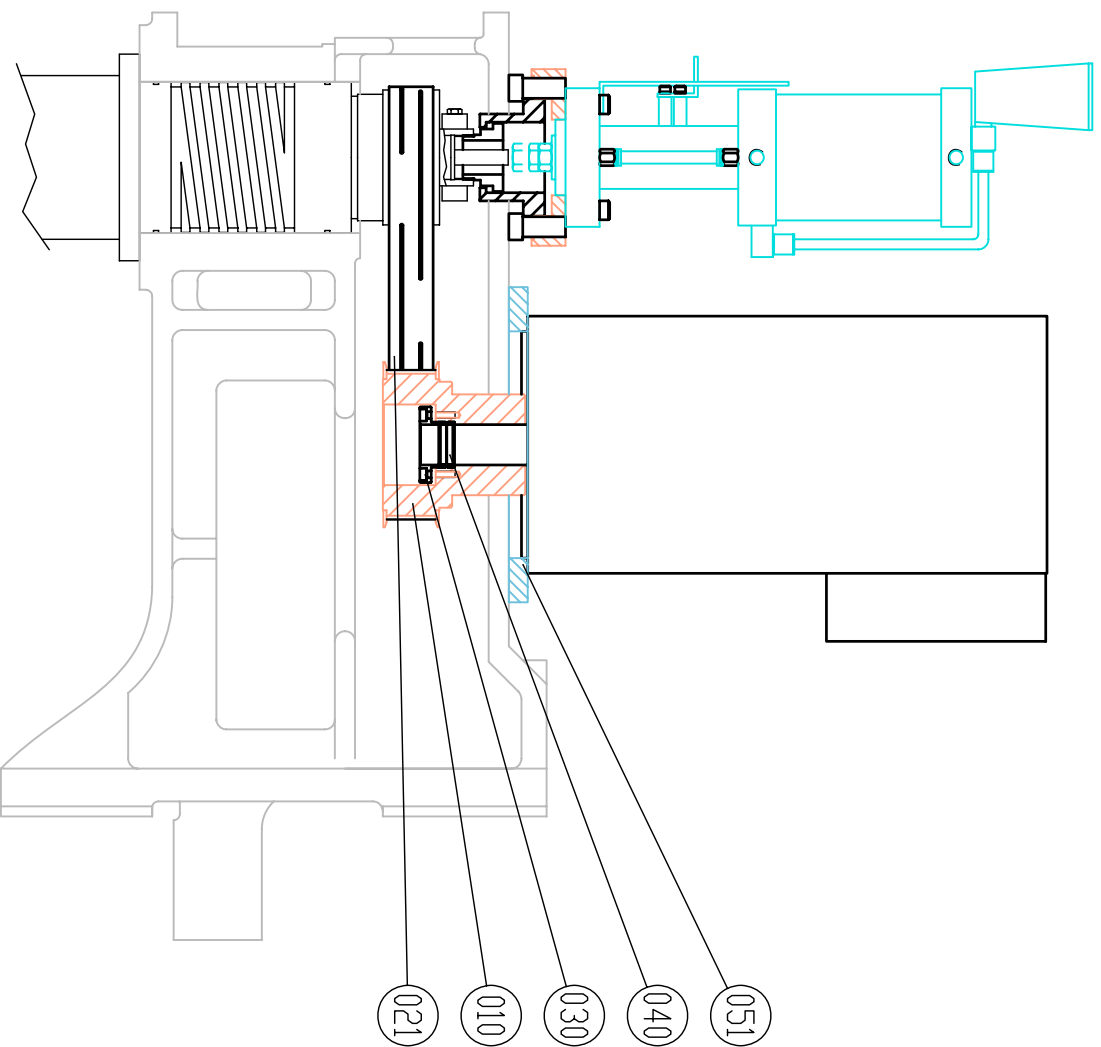

Leaderway Machinery Co. Ltd.

Scale		Drawing Name		Page	
1:6		主軸皮帶輪單元 (FANUC β8) SPINDLE BELT UNIT (FANUC β8)		1/1	
Drawn		Date		A4	
Control		97.11.10		8120001B0 (2F28008)	
張靜宜		Draw No.			

台灣力得衛宇龍科技股份有限公司

*單階材料用量清單

製表日期: 099-09-08

第1頁

主件品號	序號	元件品號	品名 英文品名	規 格	月量
2F28009			主軸皮帶輪單元(S社,H社) SPINDLE BELT UNIT	V450/V33i/V42i(1PH7107)	
	0011	3971013B0	齒型皮帶輪(5GT-75T) PULLEY	3270\S45C/ ϕ 38	1
	0021	4601035810	齒型皮帶(剖溝) PULLEY BELT	5GT*35*810	1
	0030	3500027A0	馬達軸端蓋 SHAFT END COVER	3170\S45C	1
	0041	3500011B0	主軸馬達固定板 FIXED PLATE FOR MOTOR	3170\SS41	1

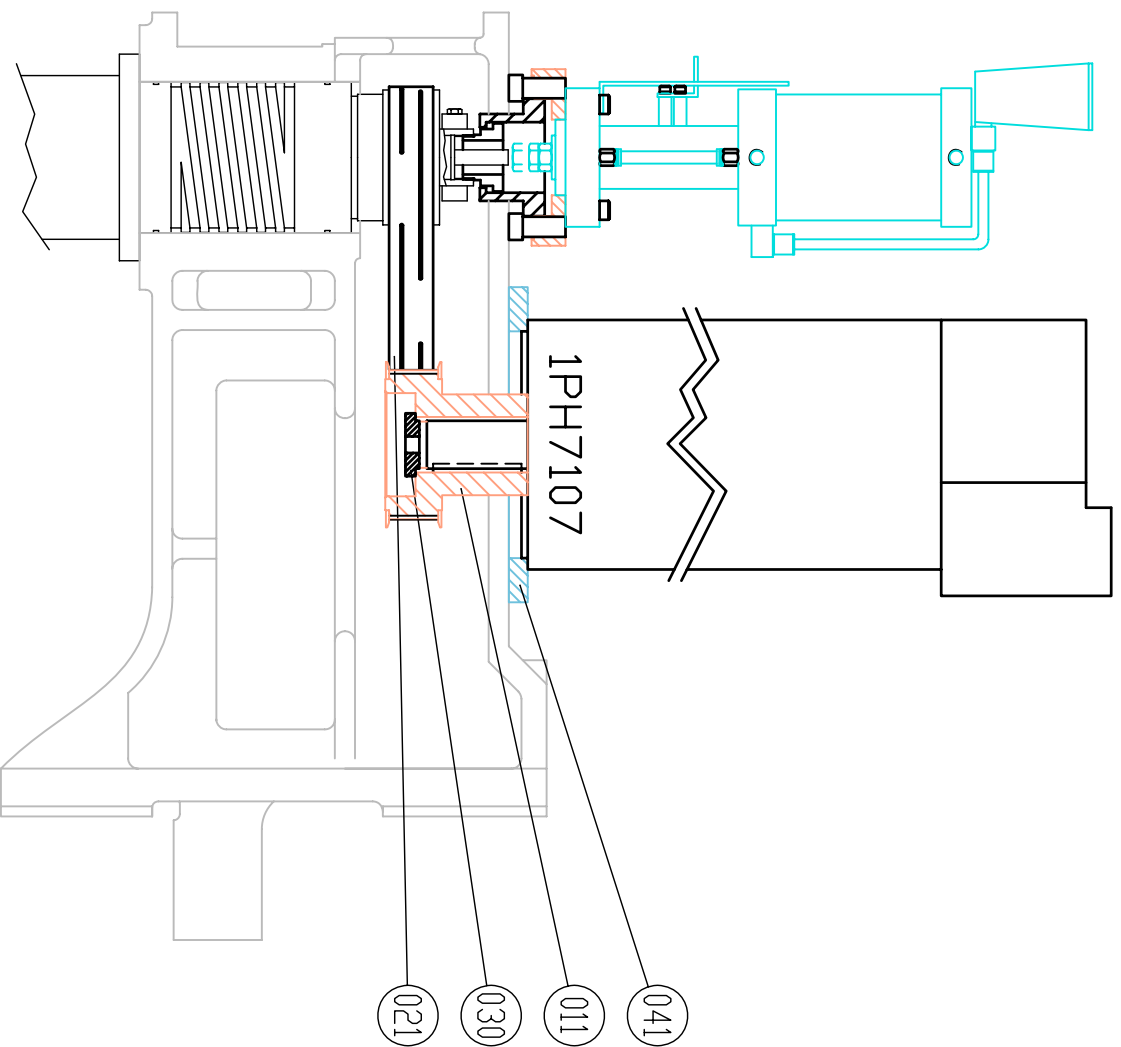

Leaderway Machinery Co. Ltd.

Scale		Drawing Name		Page	
1:6		主軸皮帶輪單元 (S、H) SPINDLE BELT UNIT (S、H)		1/1	
Drawn		Date		Draw No.	
Control		97.11.10		8120004B0 (2F28009)	
Name		Drawn		Date	
張靜宜		Control		97.11.10	

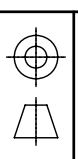

台灣力得衛宇龍科技股份有限公司

*單階材料用量清單

製表日期: 099-09-08

第1頁

主件品號	序號	元件品號	品名 英文品名	規 格	月量
2F28010			主軸皮帶輪單元(S社,H社) SPINDLE BELT UNIT	V450/V33i/V42i(1PH7107)	
	0010	3971014A0	齒型皮帶輪(5GT-90T) PULLEY	3270\S45C	1
	0021	4601035845	齒型皮帶(剖溝) PULLEY BELT	5GT*35*845	1
	0030	3500027A0	馬達軸端蓋 SHAFT END COVER	3170\S45C	1
	0041	3500011B0	主軸馬達固定板 FIXED PLATE FOR MOTOR	3170\SS41	1

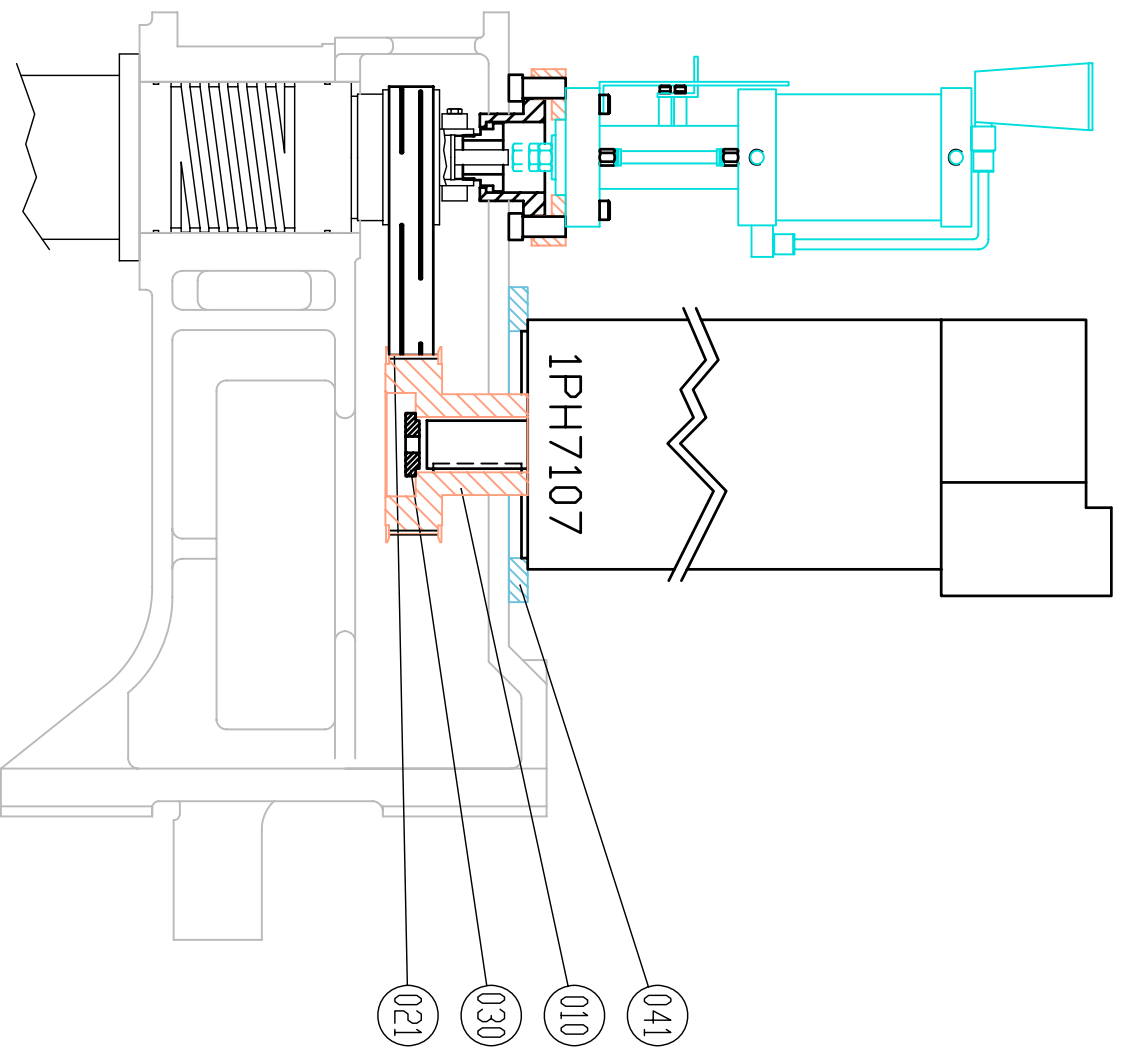

Leaderway Machinery Co. Ltd.

Scale		Drawing Name		Page	
1:6		主軸皮帶輪單元 (S、H/12K) SPINDLE BELT UNIT (S、H/12K)		1/1	
Drawn		Date		A4	
Control		97.11.10		8120005B0 (2F28010)	
張靜宜		Draw No.			

台灣力得衛宇龍科技股份有限公司

*單階材料用量清單

製表日期: 099-09-08

第1頁

主件品號	序號	元件品號	品名 英文品名	規 格	月量
2F28011			主軸皮帶輪單元 SPINDLE BELT UNIT	V450/V33i/V42i F α 8(φ 48)	
	0010	3971029A0	齒型皮帶輪 PULLEY	3270\S45C(5GT-75T/φ 48)	1
	0020	3600135A0	軸壓蓋(φ 48) SHAFT END COVER	3240\S45C	1
	0030	4061248055	迫緊環 PACKING RING	TLK300 48x55	2
	0041	4601035810	齒型皮帶(剖溝) PULLEY BELT	5GT*35*810	1
	0051	3500011B0	主軸馬達固定板 FIXED PLATE FOR MOTOR	3170\S41	1

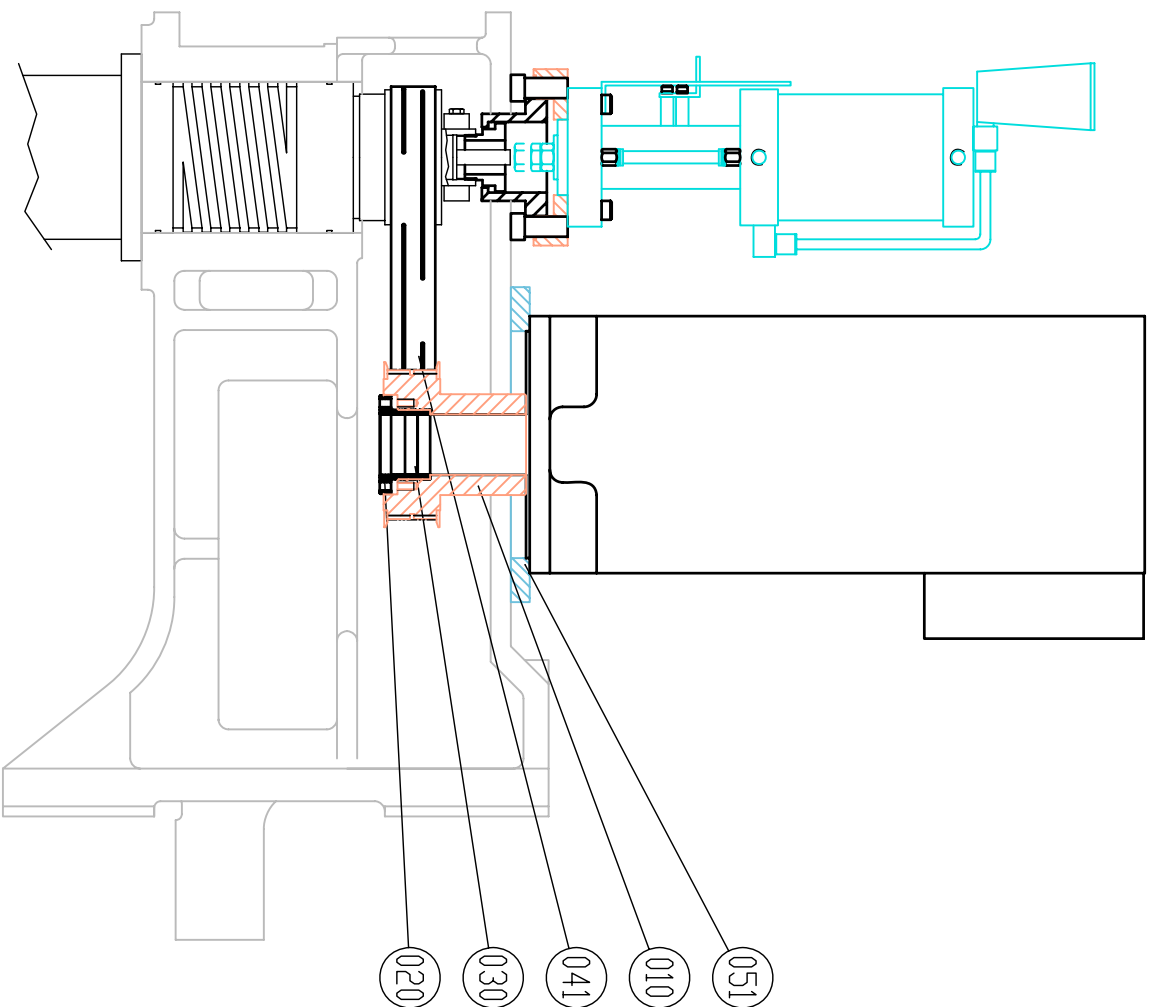

Leaderway Machinery Co. Ltd.

Scale		Drawing Name		Page	
1:6		主軸皮帶輪單元 (FANUC α8) SPINDLE BELT UNIT (FANUC α8)		1/1	
Drawn		Date		A4	
Control		97.11.10		8120006B0 (2F28011)	
張靜宜		Draw No.			

台灣力得衛宇龍科技股份有限公司

*單階材料用量清單

製表日期: 099-09-08

第1頁

主件品號	序號	元件品號	品名 英文品名	規 格	月量
2F28020			主軸皮帶輪單元 SPINDLE BELT UNIT	V450/V33i/V42i F β 8/12K	
	0010	3971007A0	齒型皮帶輪(5GT-90T) PULLEY	3270\S45C	1
	0020	4601035845	齒型皮帶(剖溝) PULLEY BELT	5GT*35*845	1
	0030	3580161A0	馬達軸端蓋 SHAFT END COVER	3170\S45C	1
	0040	4061232036	迫緊環 PACKING RING	TLK300 32x36	2
	0050	3500011B0	主軸馬達固定板 FIXED PLATE FOR MOTOR	3170\SS41	1

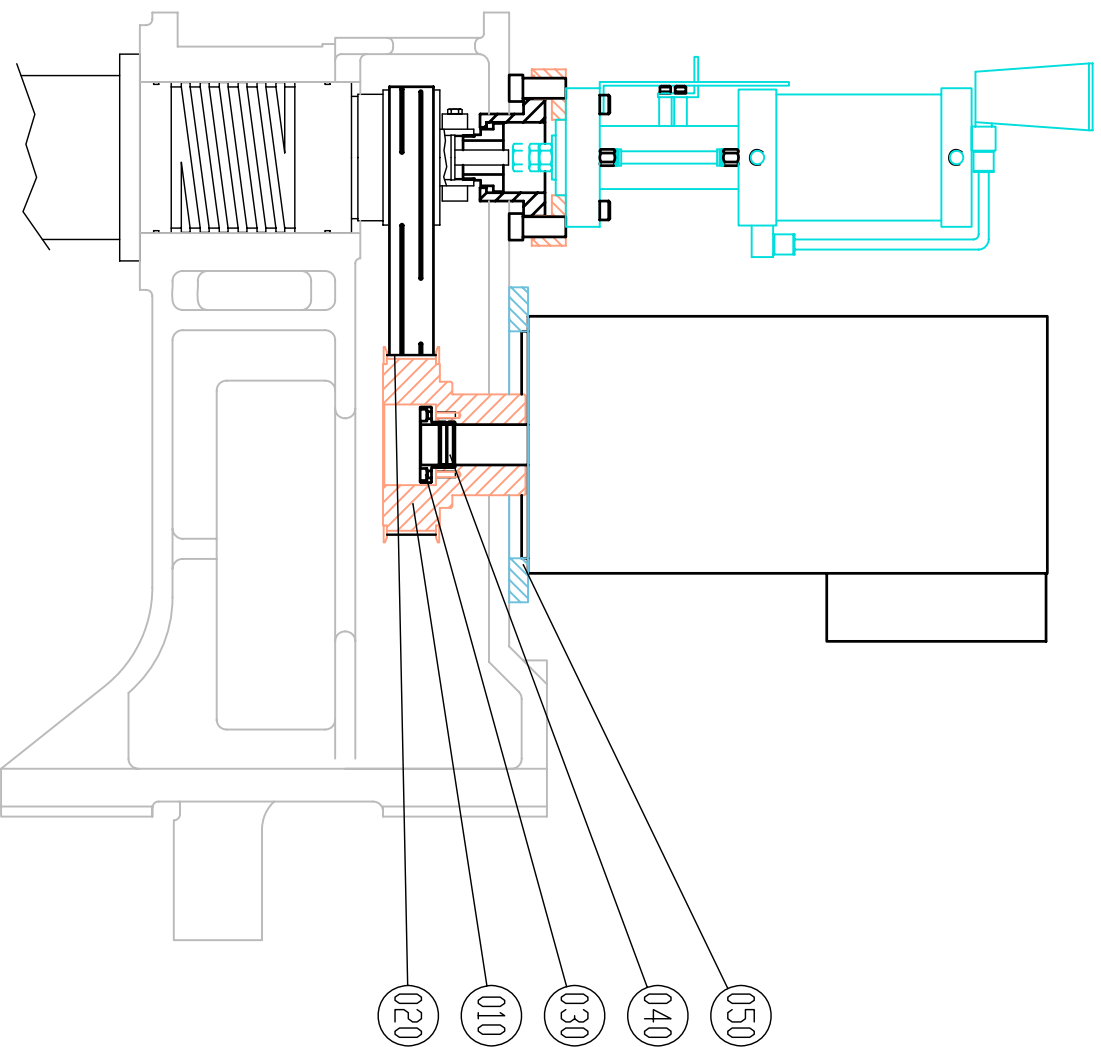

Leaderway Machinery Co. Ltd.

Scale		Drawing Name		Page	
1:6		主軸皮帶輪單元 (FANUC β8/12K) SPINDLE BELT UNIT (FANUC β8/12K)		1/1	
Drawn		Date		Draw No.	
Control		97.11.10		8120007B0 (2F28020)	
Name		Date		Draw No.	
張靜宜		97.11.10		8120007B0 (2F28020)	



台灣力得衛宇龍科技股份有限公司

*單階材料用量清單

製表日期: 099-09-08

第1頁

主件品號	序號	元件品號	品名 英文品名	規 格	月量
2F28021			主軸皮帶輪單元 SPINDLE BELT UNIT	V450/V33i/V42i F β8	
	0010	3971043A0	齒型皮帶輪(8YU/32T) PULLEY	3270\S45C	1
	0020	4600300800	齒型皮帶 PULLEY BELT	8YU-800-30	1
	0030	3581278A0	馬達軸壓蓋 SHAFT END COVER	3170\S45C	1
	0040	4061232036	迫緊環 PACKING RING	TLK300 32x36	2
	0050	3500011B0	主軸馬達固定板 FIXED PLATE FOR MOTOR	3170\SS41	1

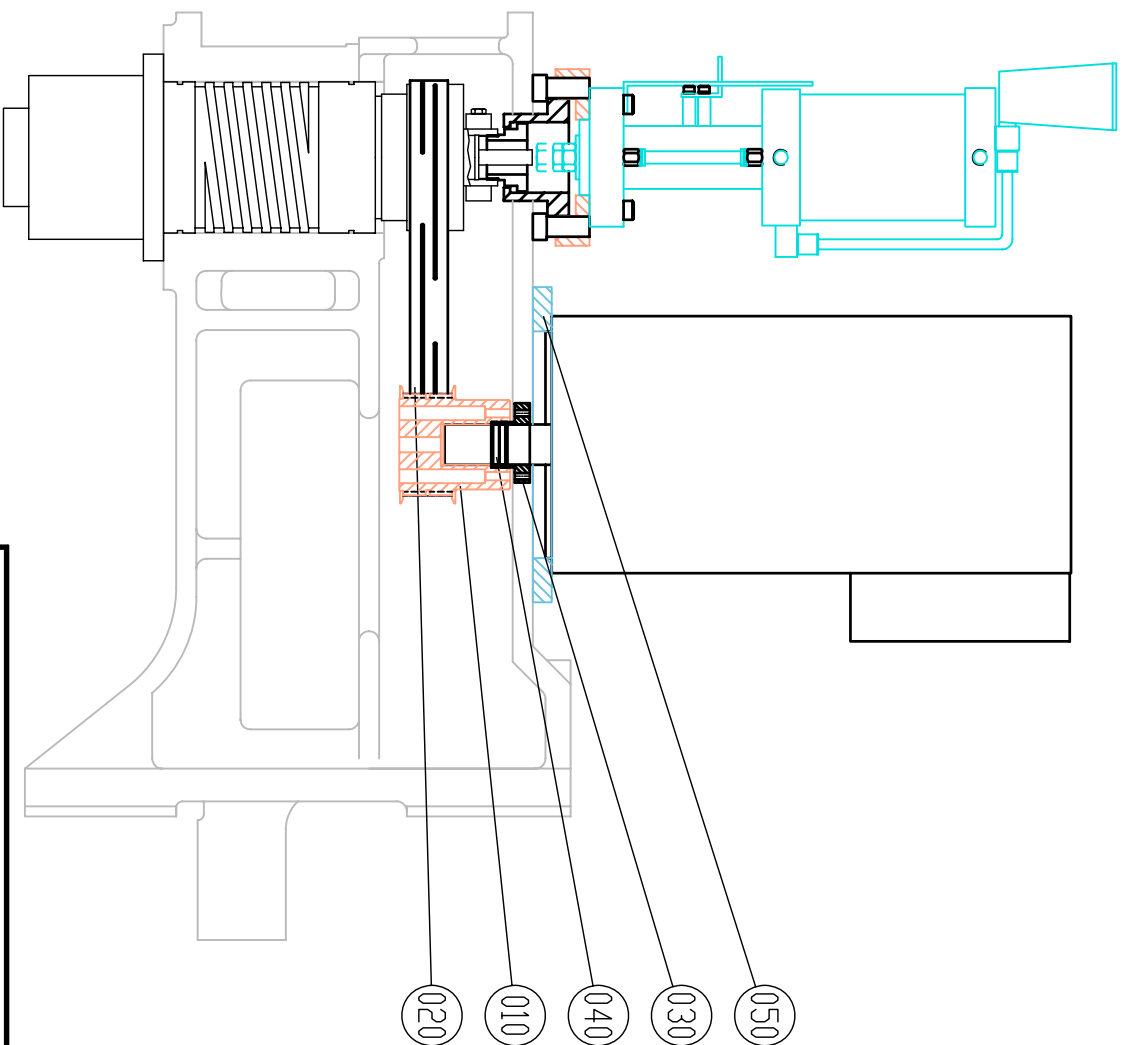

Leaderway Machinery Co. Ltd.

Scale		Drawing Name		Page	
1:6		主軸皮帶輪單元 (FANUC β8) SPINDLE BELT UNIT (FANUC β8)		1/1	
Drawn		Date		A4	
Control		97.11.10		8120008B0 (2F28021)	
張靜宜		Draw No.			

台灣力得衛宇龍科技股份有限公司

*單階材料用量清單

製表日期: 099-09-08

第1頁

主件品號	序號	元件品號	品名 英文品名	規 格	月量
2F28028			主軸皮帶輪單元\V450\V33i\V42 SPINDLE BELT UNIT	B12-Meldas SJ-V11-01ZT-S02(F	
	0010	4600235770	齒型皮帶 PULLEY BELT	5GT*35*770	1
	0020	3500011B0	主軸馬達固定板 FIXED PLATE FOR MOTOR	3170\SS41	1
	0030	3971031A0	齒型皮帶輪(5GT-60) PULLEY	3270\S45C	1
	0040	3600135A0	軸壓蓋(φ 48) SHAFT END COVER	3240\S45C	1
	0050	4061248055	迫緊環 PACKING RING	TLK300 48x55	2

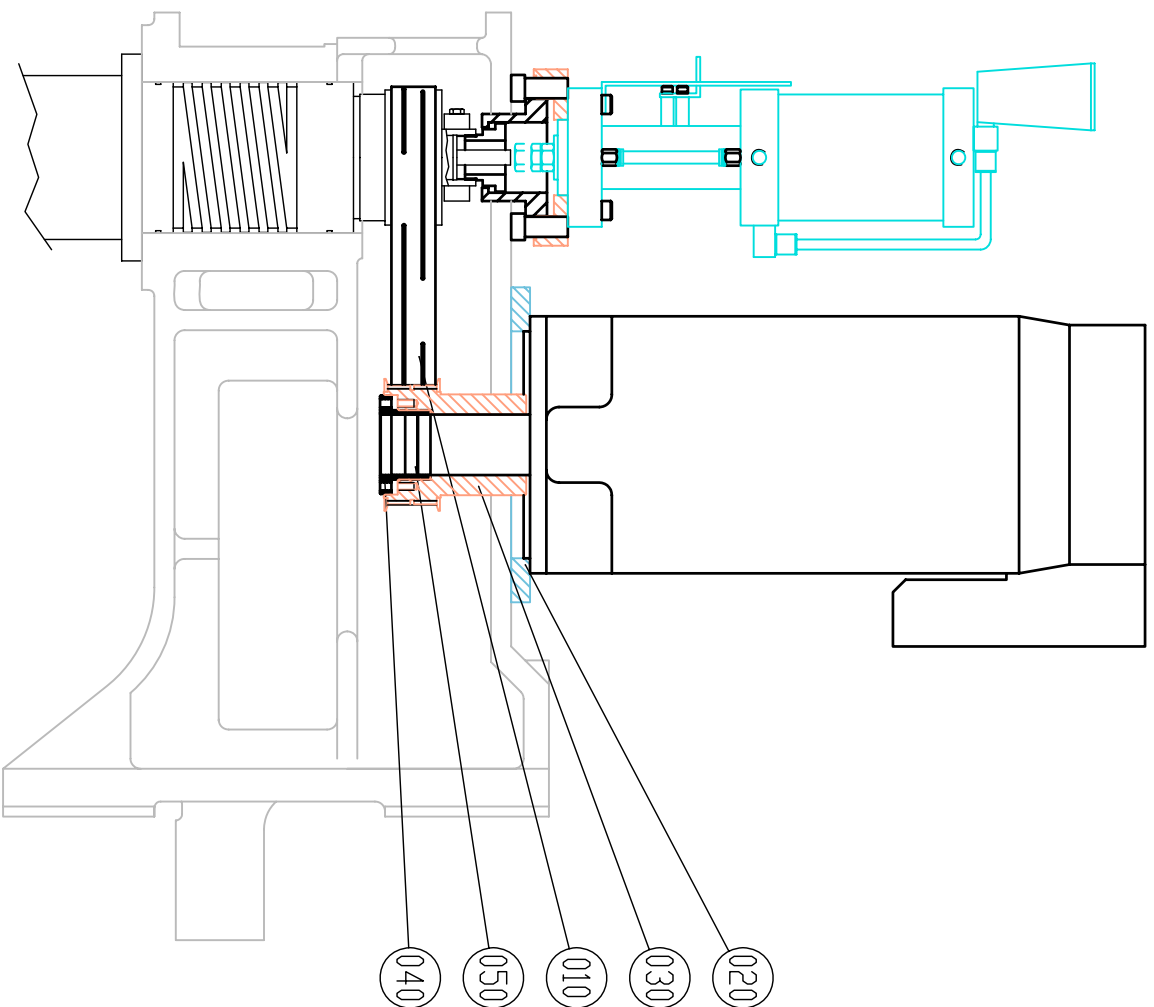

Leaderway Machinery Co. Ltd.

Scale		Drawing Name		Page	
1:6		主軸皮帶輪單元 (Meldas) SPINDLE BELT UNIT (Meldas)		1/1	
Drawn		Date		A4	
Control		97.11.10		8120009B0 (2F28028)	
張靜宜		Draw No.			

台灣力得衛宇龍科技股份有限公司

*單階材料用量清單

製表日期: 099-09-08

第1頁

主件品號	序號	元件品號	品名 英文品名	規 格	月量
2F28031			主軸皮帶輪單元 SPINDLE BELT UNIT	V33i/V42i	
	0010	3971011A0	齒型皮帶輪(5GT-75T) PULLEY	3270\S45C	1
	0020	4601035810	齒型皮帶(剖溝) PULLEY BELT	5GT*35*810	1
	0030	3500020B0	馬達軸端蓋 SHAFT END COVER	3170\S45C	1
	0040	3500011B0	主軸馬達固定板 FIXED PLATE FOR MOTOR	3170\SS41	1
	0050	3500010B0	調整檔塊 ADJUSTABLE STOPPER	3140\SS41	2

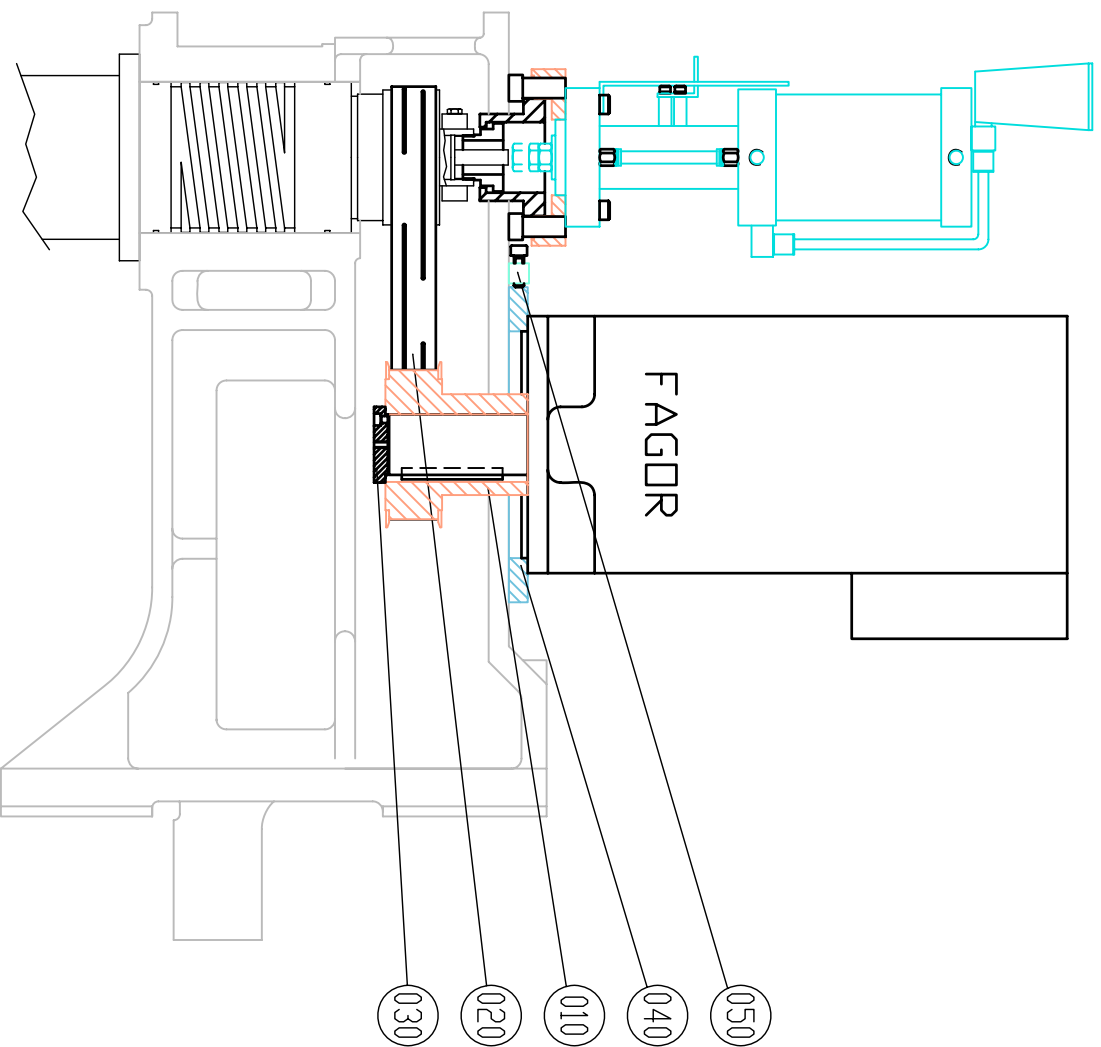

Leaderway Machinery Co. Ltd.

Scale		Drawing Name		Page	
1:6		主軸皮帶輪單元 (FAGOR 8055i) SPINDLE BELT UNIT (FAGOR 8055i)		1/1	
Drawn		Date		Draw No.	
Control		97.11.10		8120010B0 (2F28031)	
Name		Date		Draw No.	
張靜宜		97.11.10		8120010B0 (2F28031)	



台灣力得衛宇龍科技股份有限公司

*單階材料用量清單

製表日期: 099-09-08

第1頁

主件品號	序號	元件品號	品名 英文品名	規 格	用量
2F13007			底座+鞍座+工作台單元 BASE + SADDLE + TABLE UNIT	V33i	
	0013	3582005F0	底座 BASE	1030\FC-30\3582005A2	1
	0020	3600017A0	地基螺絲 FOUNDATION BOLT	3310\S45C	8
	0030	3600046A0	螺帽 (地基螺絲) NUT	3310\S45C	8
	0040	3560458A0	地基墊塊 GROUND BLOCKS	3230\S45C	8
	0070	3582001A0	噴水座 NOZZLE TUBE BRACKET	3150\SS41	2
	0080	3580048A0	碰塊座 DOG BRACKET	4140\AL(200m/m*2軌)	2
	0090	3500081A0	碰塊 DOG	3140\SS41(42m/m)	4
	0100	3540007A0	碰塊 DOG	4140\AL 外購65L	2
	0110	3985022A0	Y軸線性滑軌 LINEAR GUIDE	9840	1
	0120	3582006A0	壓塊 SLIDING BLOCK	4120	26
	0132	3581029G0	鞍座 SADDLE	1040\FC-25\3581029A2	1
	0140	4080108025	直銷(軸承鋼針) PIN	φ 8*25L	4
	0150	3581046B0	防屑蓋板 CHIP COVER	7210\SPCC	2
	0160	3581200A0	微動開關固定座 SWITCH BRACKET	7160\SPCC	1
	0170	4800143204	微動開關 MICRO SWITCH	BNS819-B02-D12-61-12-10BALLU	2
	0180	3500104C0	分油塊座 BRACKET,OIL DISTRIBUTOR BLOC	7210\SPCC	1
	0190	3582009C0	聯動管連結板 CONDUIT BRACKET	7210\SPCC	1
	0200	4640013050	方型聯動管 WIRE CONDUIT	CECBO02-26x58-142(13P)/R50	1
	0211	3985021B0	X軸線性滑軌 LINEAR GUIDE	9840	1
	0220	4080106015	直銷(軸承鋼針) PIN	φ 6x15L	38
	0231	3581021E0	工作台 TABLE	1050\FC-25\3581021E2	1
	0241	3581025B0	螺帽座 BALLSCREW HOUSING	1080\FC-25\3581025A2	1
	0250	3581031A0	碰塊座連結板 DOG BRACKET	3180\SS41	2
	0261	3560121B0	塞頭(工作台) TABLE SEALED CORK	3310\SS41	24
	0274	3581258D0	工作台前飾板 FRONT PLATE, TABLE	7210\SPCC	1
	0283	3581035D0	工作台後蓋板 REAR COVER, TABLE	7510\SPCC	1
	0292	3581257A0	X軸分油座 OIL DISTRIBUTOR BRACKET	7210\SPCC	1
	0302	3581259B0	微動開關座 SWITCH BRACKET	7160\SPCC	1
	0310	3582010C0	摺動罩軌道(Y軸) GUIDE WAY FOR TELESCOPIC COV	3130\方形鐵	2
	0321	3581202B0	Y軸前摺動罩 Y AXIS TELESCOPIC COVER UNIT	7400\SPCCZ	1

<續下頁>

台灣力得衛宇龍科技股份有限公司

*單階材料用量清單

製表日期: 099-09-08

第2頁

主件品號	序號	元件品號	品名 英文品名	規 格	月量
2F13007	0330	3581203A0	Y軸後摺動罩 Y AXIS TELESCOPIC COVER UNIT	7400\SPCCZ	1
	0341	3581039B0	摺動罩支架 TELESCOPIC COVER BRACKET	3180\SS41	4
	0354	3581037F0	X軸左摺動罩 X AXIS TELESCOPIC COVER UNIT	7400\SPCCZ	1
	0365	3581036G0	X軸右摺動罩 X AXIS TELESCOPIC COVER UNIT	7400\SPCCZ	1
	0381	3581032B0	碰塊座 DOG BRACKET	4140\AL(300m/m*2軌)	2
	0391	3581156B0	導油槽 OIL TROUGH	7520\SPCC	1
	0401	3581256B0	隔板 SEPARATOR	7180\SPCC	1

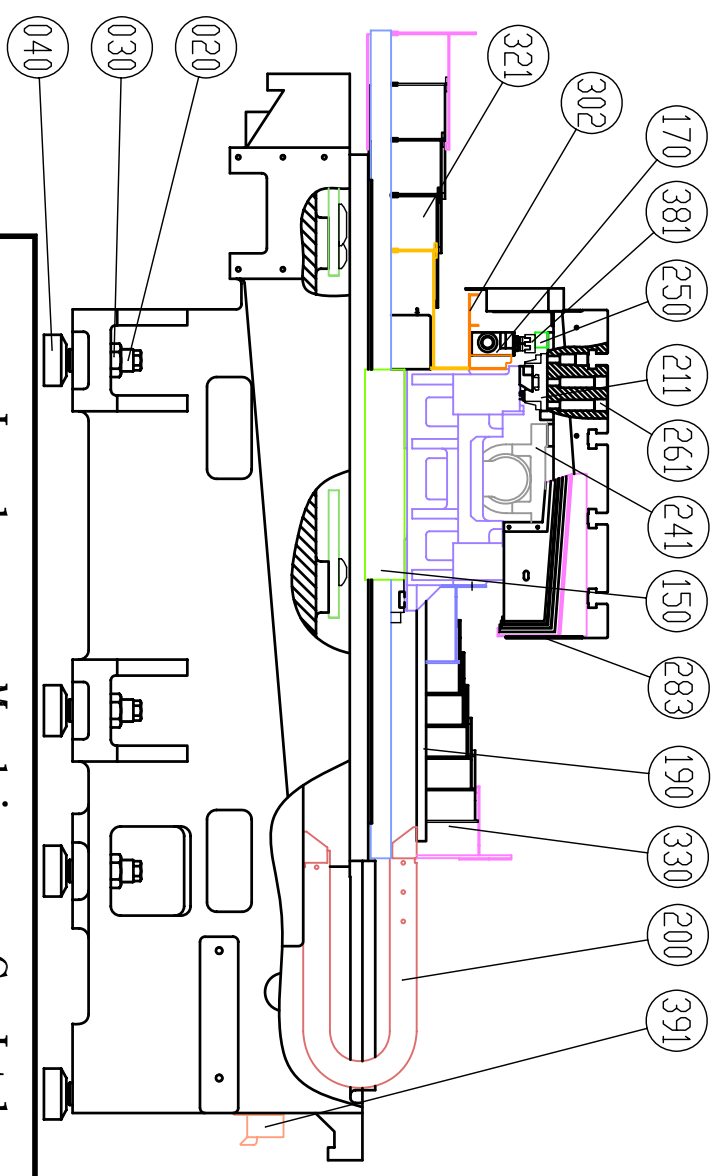
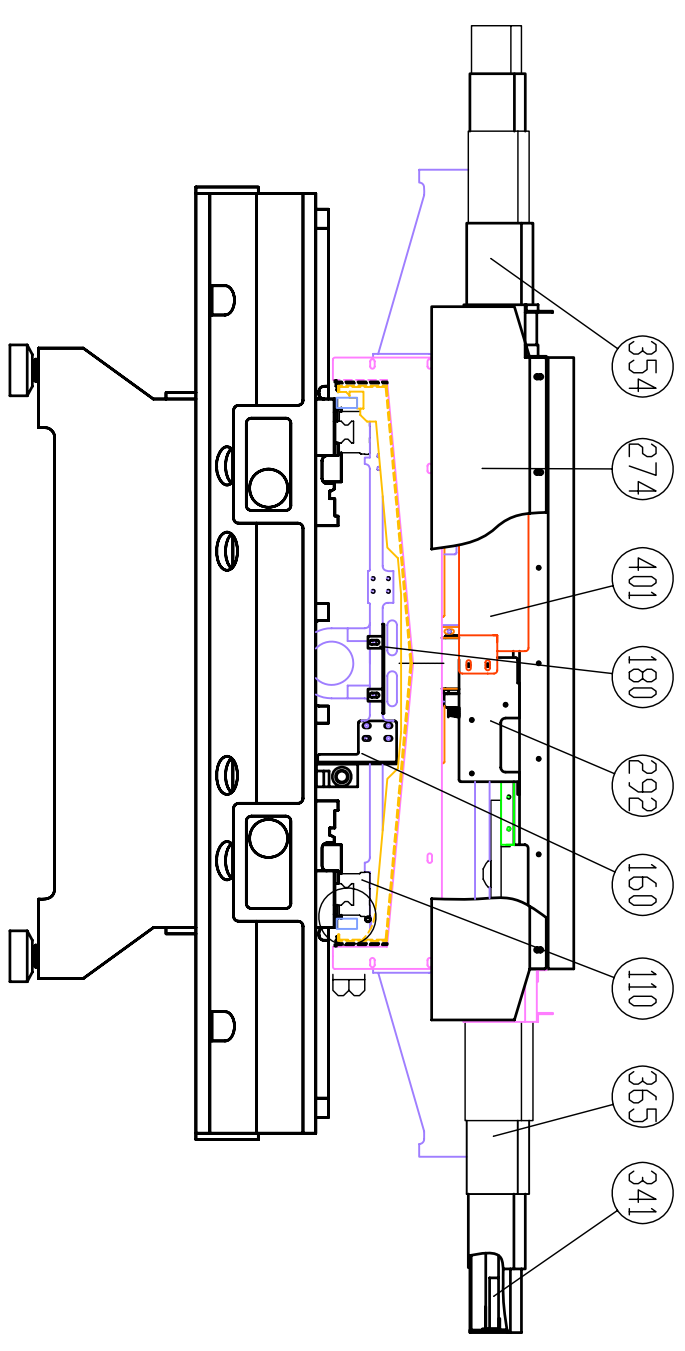
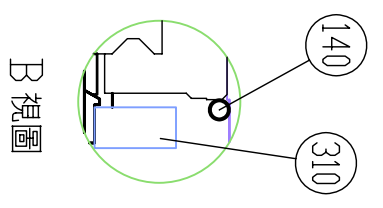
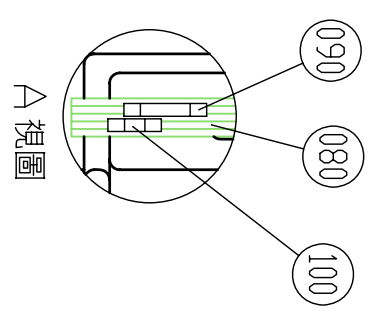
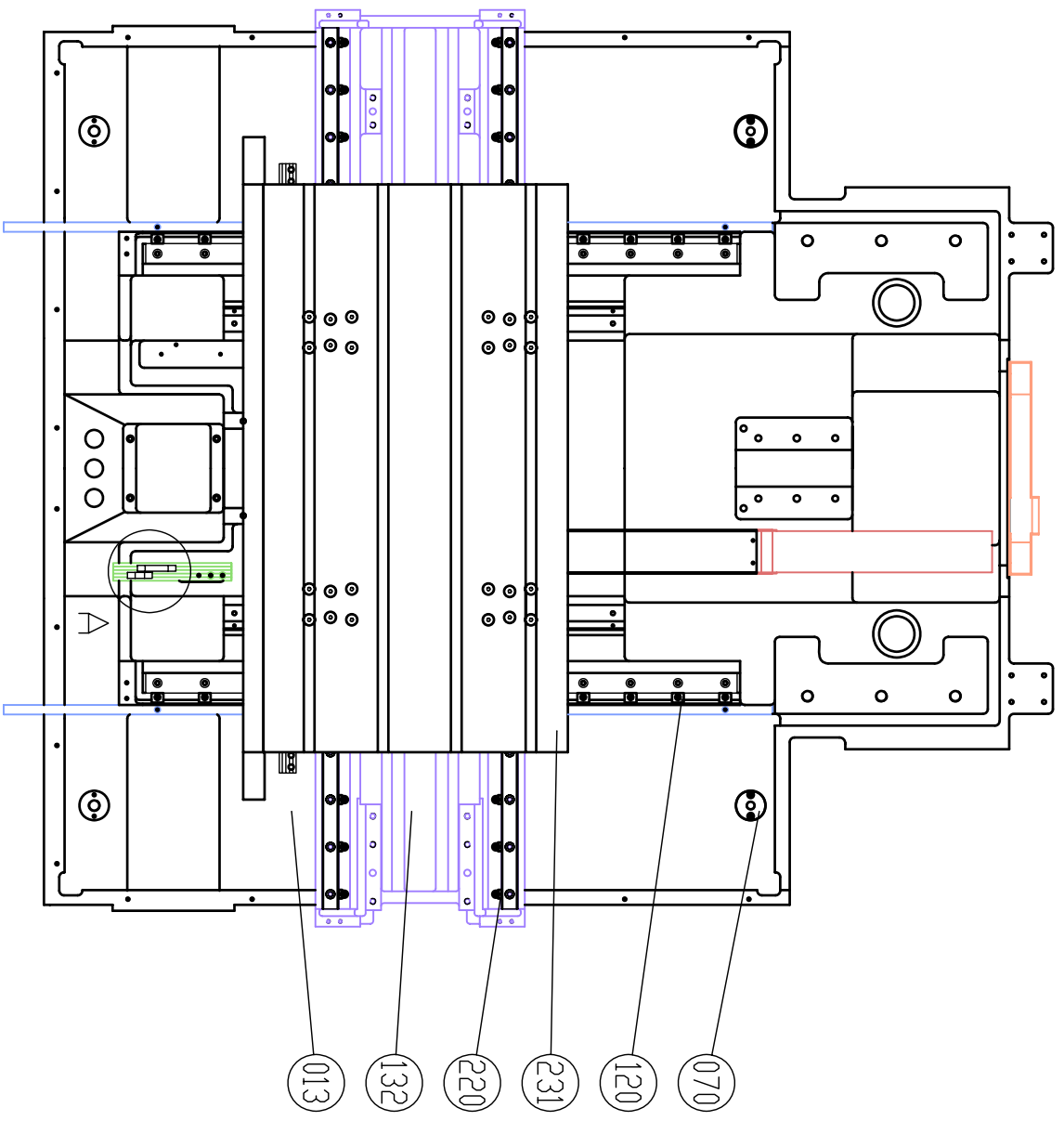

Leaderway Machinery Co. Ltd.

Scale 1:12		Drawing Name V-33i 底座+鞍座+工作台單元 V-33i BASE + SADDLE + TABLE UNIT		Page 1/1
Drawn 洪文昇	Checked 98.01.05	Drawn No. 8120276B0 (2F13007)	A3	
Control				

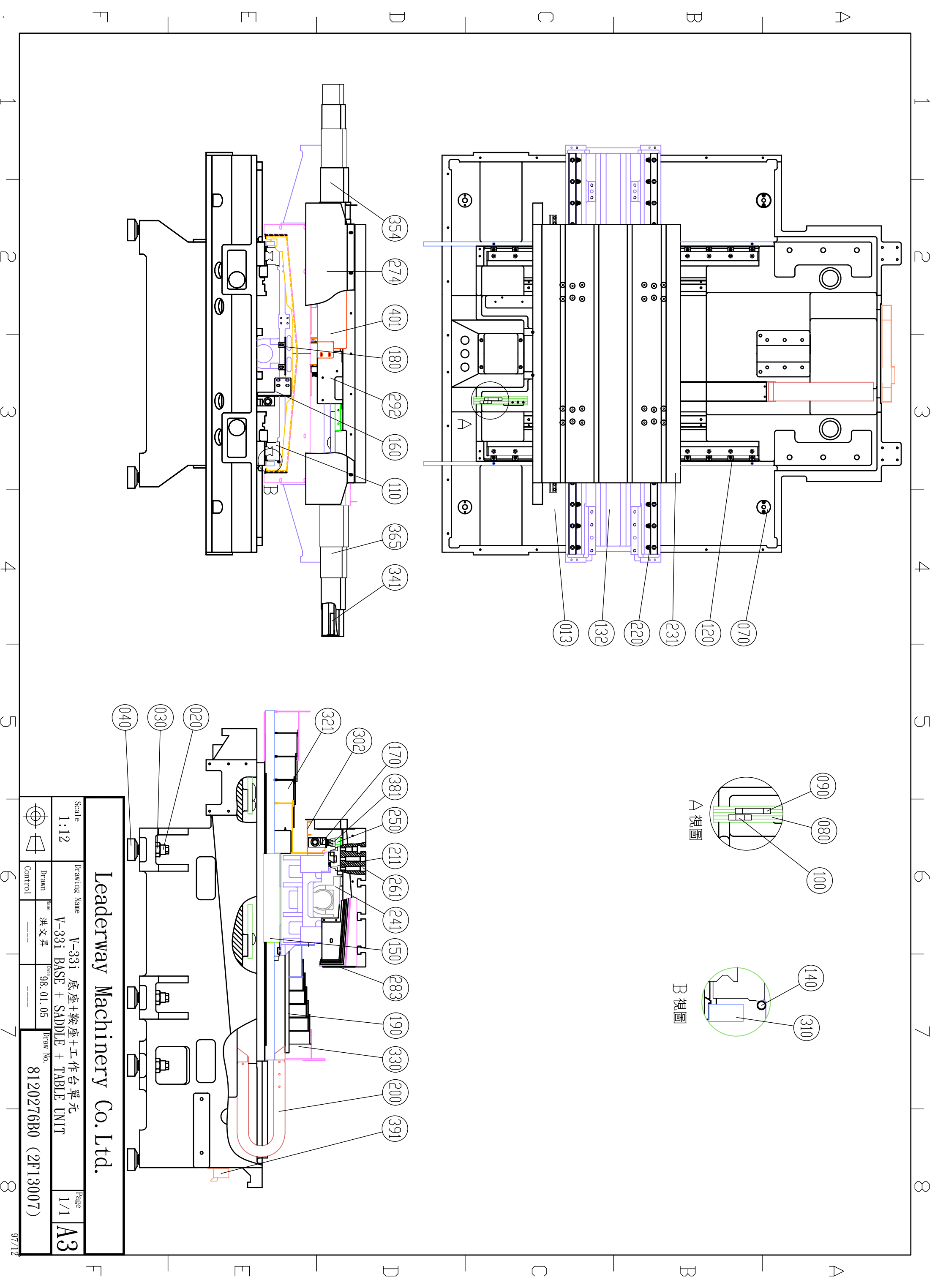

台灣力得衛宇龍科技股份有限公司

*單階材料用量清單

製表日期: 099-09-08

第1頁

主件品號	序號	元件品號	品名 英文品名	規 格	月量
2F13009			底座+鞍座+工作台單元 BASE + SADDLE + TABLE UNIT	V42i	
	0013	3582005F0	底座 BASE	1030\FC-30\3582005A2	1
	0020	3582001A0	噴水座 NOZZLE TUBE BRACKET	3150\SS41	2
	0031	3582002D0	Y軸前摺動罩 Y AXIS TELESCOPIC COVER UNIT	7400\SPCCZ	1
	0040	3582010C0	摺動罩軌道(Y軸) GUIDE WAY FOR TELESCOPIC COV	3130\方形鐵	2
	0051	3582003D0	Y軸後摺動罩 Y AXIS TELESCOPIC COVER UNIT	7400\SPCCZ	1
	0060	3985024A0	線性滑軌(Y軸) LINEAR GUIDE	9840\BRH30BL1L680PZ2 II	1
	0070	3582006A0	壓塊 SLIDING BLOCK	4120	94
	0081	3582007B0	微動開關座 SWITCH BRACKET	7160\SPCC	1
	0090	4640013050	方型聯動管 WIRE CONDUIT	CECBO02-26x58-142(13P)/R50	1
	0100	3582009C0	聯動管連結板 CONDUIT BRACKET	7210\SPCC	1
	0110	3985022A0	Y軸線性滑軌 LINEAR GUIDE	9840	1
	0120	3500081A0	碰塊 DOG	3140\SS41(42m/m)	4
	0130	3540007A0	碰塊 DOG	4140\AL 外購65L	2
	0141	3500083A0	碰塊座 DOG BRACKET	4140\AL(90m/m*3軌)	1
	0150	3600017A0	地基螺絲 FOUNDATION BOLT	3310\S45C	8
	0160	3600046A0	螺帽(地基螺絲) NUT	3310\S45C	8
	0170	3560458A0	地基墊塊 GROUND BLOCKS	3230\S45C	8
	0202	3582004F0	鞍座 SADDLE	1040\FC-30\3582004B2	1
	0225	3582130C0	X軸摺動罩(右) X AXIS TELESCOPIC COVER UNIT	7400\SPCCZ	1
	0235	3582131C0	X軸摺動罩(左) X AXIS TELESCOPIC COVER UNIT	7400\SPCCZ	1
	0242	3582082B0	微動開關座 SWITCH BRACKET	7160\SPCC	1
	0252	3581090F0	工作台 TABLE	1050\FC-30\3581090E2	1
	0262	3581151B0	碰塊座連結板 DOG BRACKET	3180\SS41	2
	0270	3581032B0	碰塊座 DOG BRACKET	4140\AL(300m/m*2軌)	2
	0282	3582133A0	工作台後飾板 REAR PLATE, TABLE	7510\SPCC	1
	0292	3582132A0	工作台前飾板 FRONT PLATE, TABLE	7510\SPCC	1
	0300	3582018A0	鞍座下飾板 LOWER PLATE	7210\SPCC	2
	0312	3985050A0	X軸線性滑軌 LINEAR GUIDE	BRH35AL2-P-ZZ-L1800 II	1
	0321	3582065C0	X軸分油座 OIL DISTRIBUTOR BRACKET	7210\SPCC	1
	0331	3582079B0	油分配器座(Y軸) DISTRIBUTOR BRACKET	7210\SPCC	1

<續下頁>

台灣力得衛宇龍科技股份有限公司

*單階材料用量清單

製表日期: 099-09-08

第2頁

主件品號	序號	元件品號	品名 英文品名	規 格	月量
2F13009	0340	4800143204	微動開關 MICRO SWITCH	BNS819-B02-D12-61-12-10BALLU	2
	0350	3500082B0	碰塊座 DOG BRACKET	4140\AL(125m/m*3軌)	1
	0361	3581240B0	Y軸前護蓋支架 PROTECTING COVER BRACKET	7210\SPCC	2
	0380	4640028849	塑鋼製鏈條式聯動管 ELECTRICAL CONDUIT UNIT		1
	0391	3560121B0	塞頭(工作台) TABLE SEALED CORK	3310\SS41	16
	0401	3581156B0	導油槽 OIL TROUGH	7520\SPCC	1
	0410	3582128A0	螺絲襯套 BUSHING	4230\不鏽鋼	8
	0420	3581025B0	螺帽座 BALLSCREW HOUSING	1080\FC-25\3581025A2	1
	0430	3582129B0	X軸摺動罩支架 TELESCOPIC COVER BRACKET	3180\SS41	4

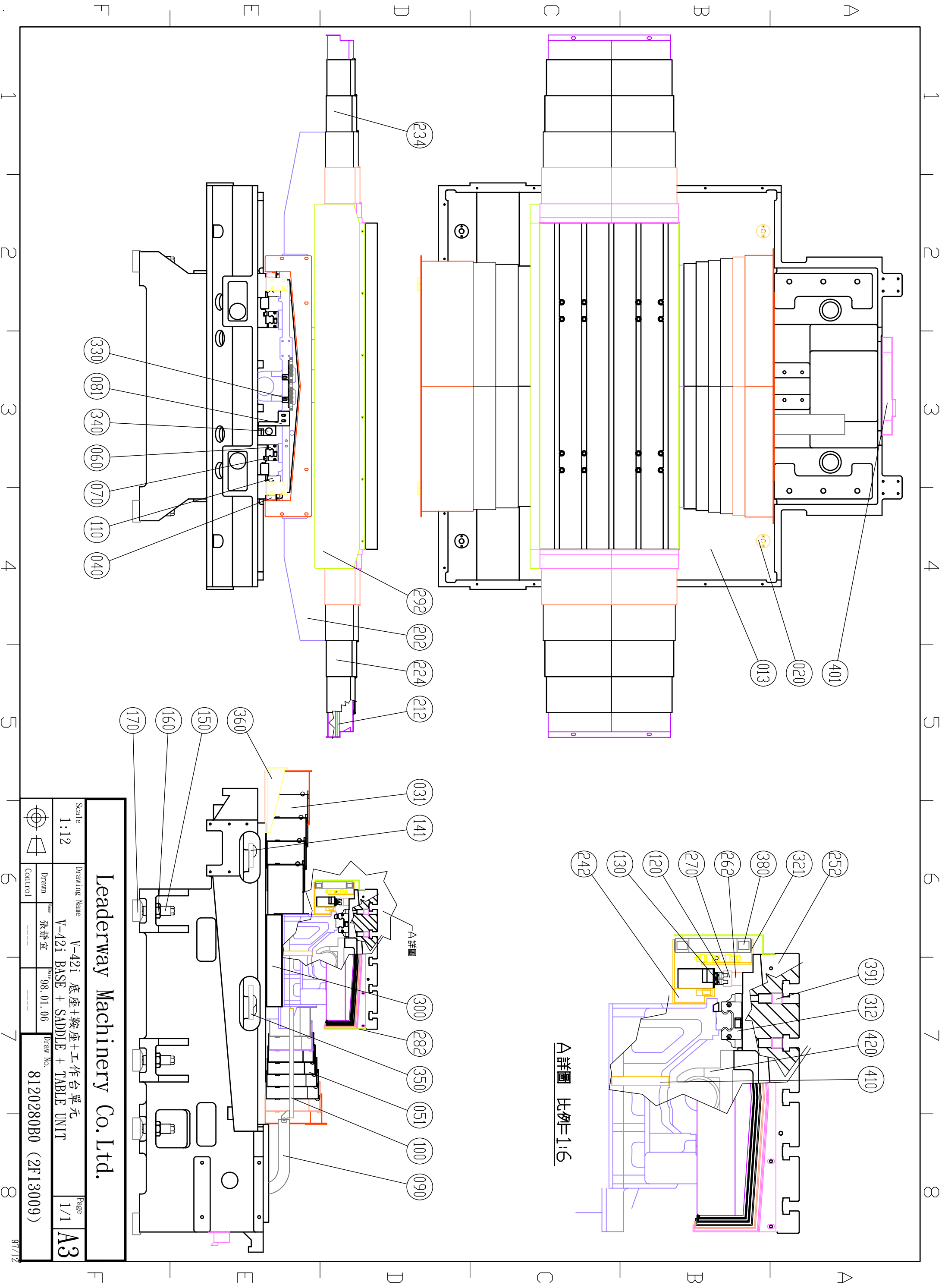

Leaderway Machinery Co. Ltd.

Scale		Drawing Name		Page	
1:12		V-42i 底座+鞍座+工作台單元 V-42i BASE + SADDLE + TABLE UNIT		1/1	
Drawn		Name		Draw No.	
Control		張靜宜		8120280B0 (2F13009)	
		Date		98.01.06	

台灣力得衛宇龍科技股份有限公司

*單階材料用量清單

製表日期: 099-09-08

第1頁

主件品號	序號	元件品號	品名 英文品名	規 格	月量
2F21007			X軸傳動單元 X AXIS TRANSMISSION UNIT	V33i	
	0011	3170053B0	軸承隔環 BEARING SPACER	3230\SCM4	1
	0021	3170054B0	前迷宮環座 LAMINAL RING BRACKET	3250\SCM4	2
	0031	3170057B0	軸承隔環 BEARING SPACER	3230\SCM4	1
	0040	3170067A0	預拉彈簧檔片 PRELOAD SPRING STOPPER	3230\S45C	1
	0050	3170070A0	Z軸尾端軸承座 REAR BEARING HOUSING	1080\S45C	1
	0061	3560016B0	軸承壓蓋 BEARING CAP	3240\SCM4	1
	0070	3560017B0	防撞膠塊 RUBBER CUSHION	4370\PU	2
	0083	3560018G0	防撞膠塊固定座 RUBBER CUSHION BRACKET	3240\SCM4	1
	0090	3560019B0	防撞膠固定座 RUBBER CUSHION BRACKET	3230\S45C	1
	0102	3560023E0	Z軸尾端軸承座壓板 PUSHING PLATE,BEARING HOUSI	3120\SCM4	1
	0110	3560132B0	尾端座蓋板 REAR BEARING HOUSING COVER	3180\SPCC	1
	0120	3581022B0	尾端座(X軸) REAR BEARING HOUSING	1080\FC-25\3581022B2	1
	0130	3581027B0	傳動座 TRANSMISSION HOUSING	1080\FC-25\3581027B2	1
	0140	3984022B0	滾珠螺桿 BALL SCREW	9860\φ 40xP16	1
	0150	4020401030	鎖緊螺帽 LOCK NUT	MK30	1
	0160	4020403035	鎖緊螺帽 LOCK NUT	MF35(M35xP1.5)	1
	0170	4050175012	壓縮彈簧 COMPRESSIVE SPRING	φ 1.25X φ 7.5X12L	8
	0180	4061306828	迷宮環 LAMINAL RING	FK3-AS 62/2.8/0.82	6
	0190	4402030062	螺桿軸承 BALL SCREW BEARING	BS30M62/15-P4A.DUM	1
	0200	4402435072	螺桿軸承 BALL SCREW BEARING	BS35/72/15TUM	1
	0210	3581053A0	傳動座蓋板 TRANSMISSION HOUSING COVER	7180\SPCC	1
	0222	3581092D0	迷宮環座 LAMINAL RING BRACKET	3250\SCM4	1
	0230	4061300001	迷宮環 LAMINAL RING	FK3-AS 68/2.8/0.82	3
	0240	4080508050	斜梢 SLIDE PIN	#8x50L(附內牙)	4

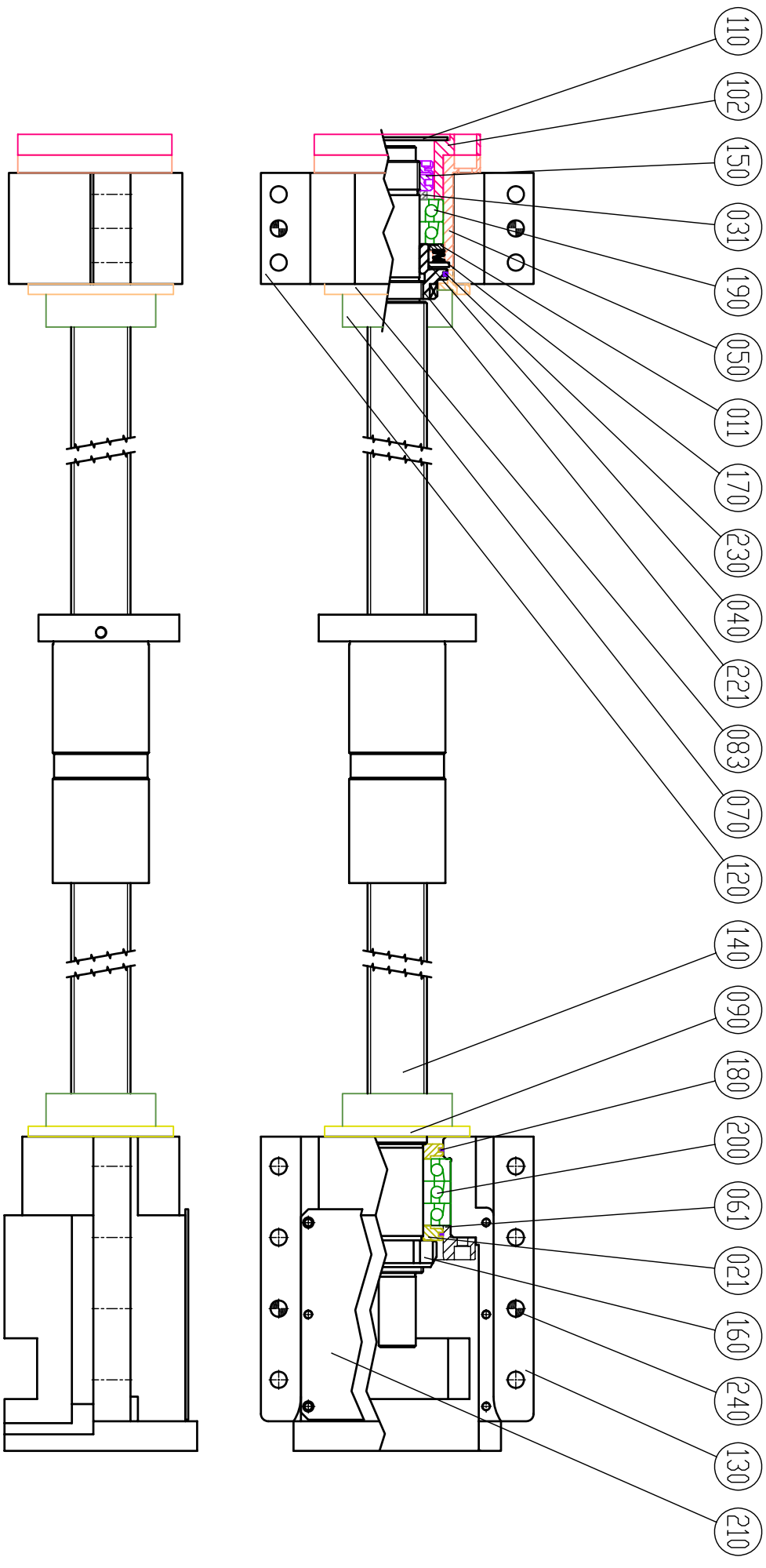

Leaderway Machinery Co. Ltd.

Scale 1:4		Drawing Name V-33i X軸傳動單元 V-33i X AXIS TRANSMISSION UNIT		Page 1/1
	Drawn 張靜宜	Date 98. 10. 07	Draw No. 8120198C0 (2F21007)	A4
	Control			

台灣力得衛宇龍科技股份有限公司

*單階材料用量清單

製表日期: 099-09-08

第1頁

主件品號	序號	元件品號	品名 英文品名	規 格	月量
2F21009			X軸傳動單元 X AXIS TRANSMISSION UNIT	V42i	
	0011	3170053B0	軸承隔環 BEARING SPACER	3230\SCM4	1
	0021	3170054B0	前迷宮環座 LAMINAL RING BRACKET	3250\SCM4	2
	0031	3170057B0	軸承隔環 BEARING SPACER	3230\SCM4	1
	0040	3170067A0	預拉彈簧檔片 PRELOAD SPRING STOPPER	3230\S45C	1
	0050	3170070A0	Z軸尾端軸承座 REAR BEARING HOUSING	1080\S45C	1
	0061	3560016B0	軸承壓蓋 BEARING CAP	3240\SCM4	1
	0070	3560017B0	防撞膠塊 RUBBER CUSHION	4370\PU	2
	0083	3560018G0	防撞膠塊固定座 RUBBER CUSHION BRACKET	3240\SCM4	1
	0090	3560019B0	防撞膠固定座 RUBBER CUSHION BRACKET	3230\S45C	1
	0102	3560023E0	Z軸尾端軸承座壓板 PUSHING PLATE,BEARING HOUSI	3120\SCM4	1
	0110	3560132B0	尾端座蓋板 REAR BEARING HOUSING COVER	3180\SPCC	1
	0120	3581022B0	尾端座(X軸) REAR BEARING HOUSING	1080\FC-25\3581022B2	1
	0130	3581027B0	傳動座 TRANSMISSION HOUSING	1080\FC-25\3581027B2	1
	0140	3984028A0	滾珠螺桿 BALL SCREW	9860\φ 40xp16	1
	0150	4020401030	鎖緊螺帽 LOCK NUT	MK30	1
	0160	4020403035	鎖緊螺帽 LOCK NUT	MF35(M35xP1.5)	1
	0170	4050175012	壓縮彈簧 COMPRESSIVE SPRING	φ 1.25X φ 7.5X12L	8
	0180	4061306828	迷宮環 LAMINAL RING	FK3-AS 62/2.8/0.82	6
	0190	4402030062	螺桿軸承 BALL SCREW BEARING	BS30M62/15-P4A.DUM	1
	0200	4402435072	螺桿軸承 BALL SCREW BEARING	BS35/72/15TUM	1
	0210	3581053A0	傳動座蓋板 TRANSMISSION HOUSING COVER	7180\SPCC	1
	0222	3581092D0	迷宮環座 LAMINAL RING BRACKET	3250\SCM4	1
	0230	4061300001	迷宮環 LAMINAL RING	FK3-AS 68/2.8/0.82	3
	0250	4080508050	斜梢 SLIDE PIN	#8x50L(附內牙)	4

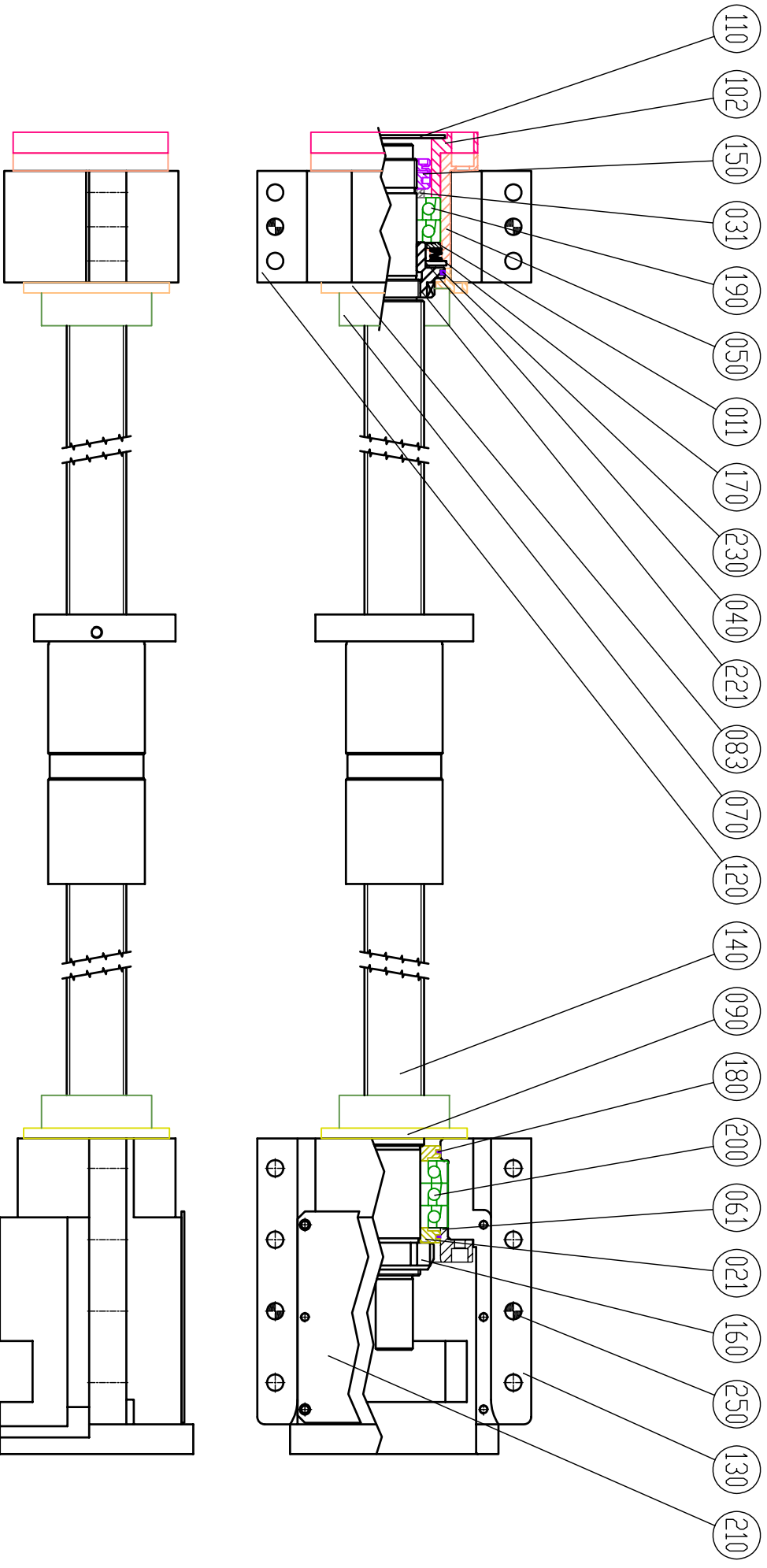

Leaderway Machinery Co. Ltd.

Scale		Drawing Name		Page	
1:4		V-42i X軸傳動單元		1/1	
Drawn		V-42i X AXIS TRANSMISSION UNIT		A4	
Control		Name: 張靜宜		Date: 98.10.07	
		Date: 98.10.07		Draw No. 8120281C0 (2F21009)	

台灣力得衛宇龍科技股份有限公司

*單階材料用量清單

製表日期: 099-09-08

第1頁

主件品號	序號	元件品號	品名 英文品名	規 格	月量
2F22005			Y軸傳動單元 Y AXIS TRANSMISSION UNIT	V33i/V42i	
	0011	3170053B0	軸承隔環 BEARING SPACER	3230\SCM4	1
	0021	3170054B0	前迷宮環座 LAMINAL RING BRACKET	3250\SCM4	2
	0031	3170057B0	軸承隔環 BEARING SPACER	3230\SCM4	1
	0040	3170067A0	預拉彈簧檔片 PRELOAD SPRING STOPPER	3230\S45C	1
	0050	3170070A0	Z軸尾端軸承座 REAR BEARING HOUSING	1080\S45C	1
	0061	3560016B0	軸承壓蓋 BEARING CAP	3240\SCM4	1
	0073	3560018G0	防撞膠塊固定座 RUBBER CUSHION BRACKET	3240\SCM4	1
	0080	3560019B0	防撞膠固定座 RUBBER CUSHION BRACKET	3230\S45C	1
	0092	3560023E0	Z軸尾端軸承座壓板 PUSHING PLATE, BEARING HOUSI	3120\SCM4	1
	0100	3560132B0	尾端座蓋板 REAR BEARING HOUSING COVER	3180\SPCC	1
	0110	3560374A0	防撞膠塊 RUBBER CUSHION	4370\PU	2
	0120	3581022B0	尾端座(X軸) REAR BEARING HOUSING	1080\FC-25\3581022B2	1
	0132	3581280A0	傳動座 TRANSMISSION HOUSING	1080\FC-30\3581280A2	1
	0140	3984023B0	滾珠螺桿 BALL SCREW	9860	1
	0150	4020401030	鎖緊螺帽 LOCK NUT	MK30	1
	0160	4020403035	鎖緊螺帽 LOCK NUT	MF35(M35xP1.5)	1
	0170	4050175012	壓縮彈簧 COMPRESSIVE SPRING	φ 1.25X φ 7.5X12L	8
	0180	4061306828	迷宮環 LAMINAL RING	FK3-AS 62/2.8/0.82	6
	0190	4402030062	螺桿軸承 BALL SCREW BEARING	BS30M62/15-P4A.DUM	1
	0200	4402435072	螺桿軸承 BALL SCREW BEARING	BS35/72/15TUM	1
	0211	3581281A0	傳動座蓋板 TRANSMISSION HOUSING COVER	7180\SPCC	1
	0222	3581092D0	迷宮環座 LAMINAL RING BRACKET	3250\SCM4	1
	0230	4061300001	迷宮環 LAMINAL RING	FK3-AS 68/2.8/0.82	3
	0240	4080508050	斜梢 SLIDE PIN	#8x50L(附內牙)	4

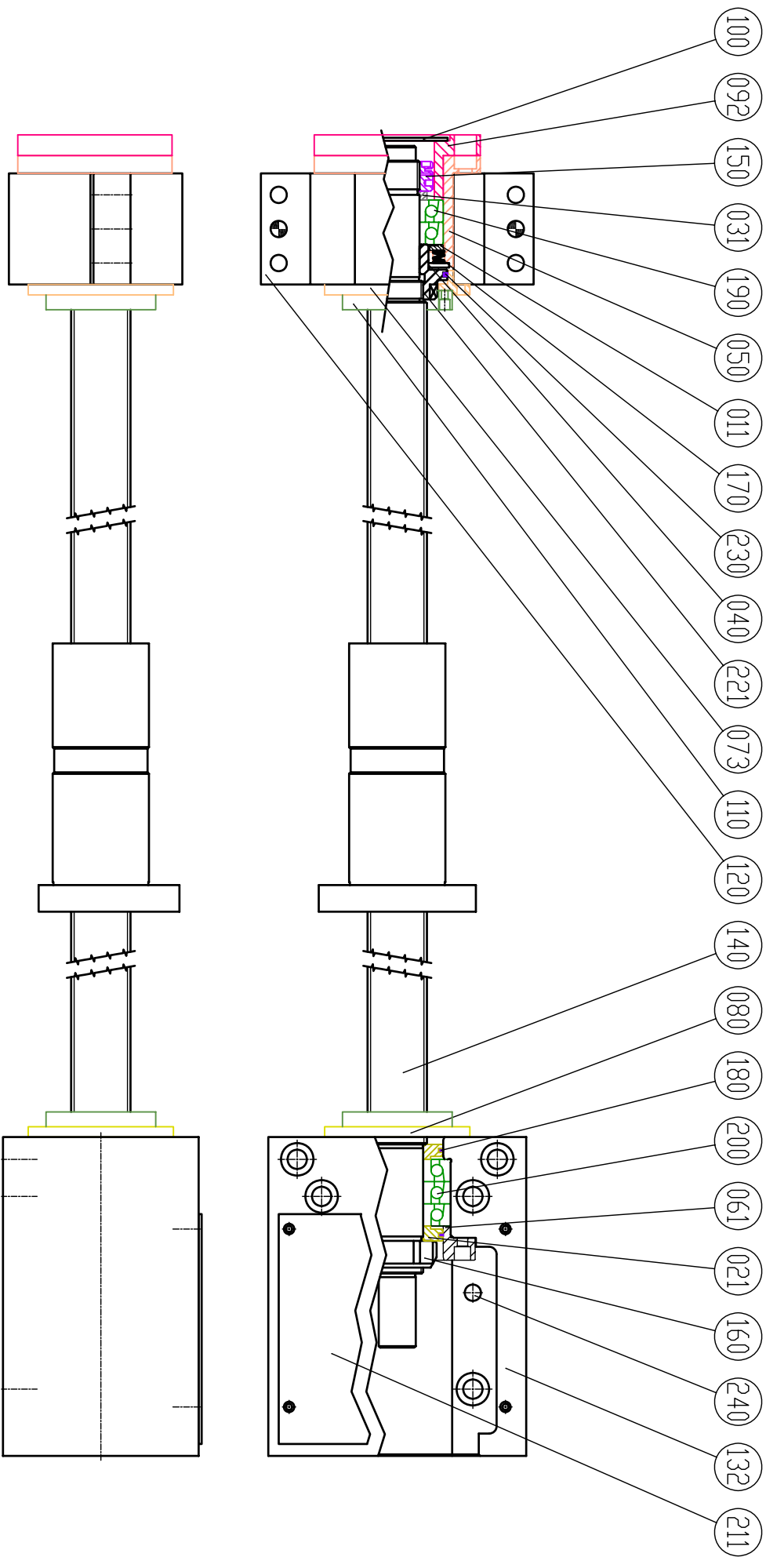

Leaderway Machinery Co. Ltd.

Scale		Drawing Name		Page	
1:4		V-33i/V-42i Y軸傳動單元		1/1	
Drawn		V-33i/V-42i Y AXIS TRANSMISSION UNIT		A4	
Control		Name: 張靜宜		Date: 98.10.07	
Control		Date: 98.10.07		Draw No. 8120264C0 (2F22005)	

台灣力得衛宇龍科技股份有限公司

*單階材料用量清單

製表日期: 099-09-08

第1頁

主件品號	序號	元件品號	品名 英文品名	規 格	月量
2F23002			Z軸傳動單元 Z AXIS TRANSMISSION UNIT	V650/V33i/V42i	
	0011	3500441A0	軸承座組件 BEARING HOUSING UNIT	9080	1
	0022	3500440B0	傳動座 TRANSMISSION HOUSING	1080\FC-25\3500440A2	1
	0030	3580005A0	尾端軸承座 REAR BEARING HOUSING	1080\FC-25\3580005A2	1
	0040	3580012A0	壓蓋 GLAND	3240\S45C	1
	0050	3580014A0	隔環 SPACER	3230\S45C	1
	0060	3580016A0	軸承座 BEARING HOUSING	3250\S45C	1
	0070	3984005A0	Z軸 BALL SCREW Z AXIS BALL SCREW	9860	1
	0080	4060700025	C型扣環(軸用) C TYPE RETAINER RING	S-25	1
	0090	4080610040	平行銷附內牙 STRAIGHT PIN	M10x40L	4
	0100	4400206205	深槽滾珠軸承 BEARING	6205ZZ	1
	0111	3560132B0	尾端座蓋板 REAR BEARING HOUSING COVER	3180\SPCC	1
	0121	3500284B0	傳動座蓋板 TRANSMISSION HOUSING COVER	7180\SPCC	1

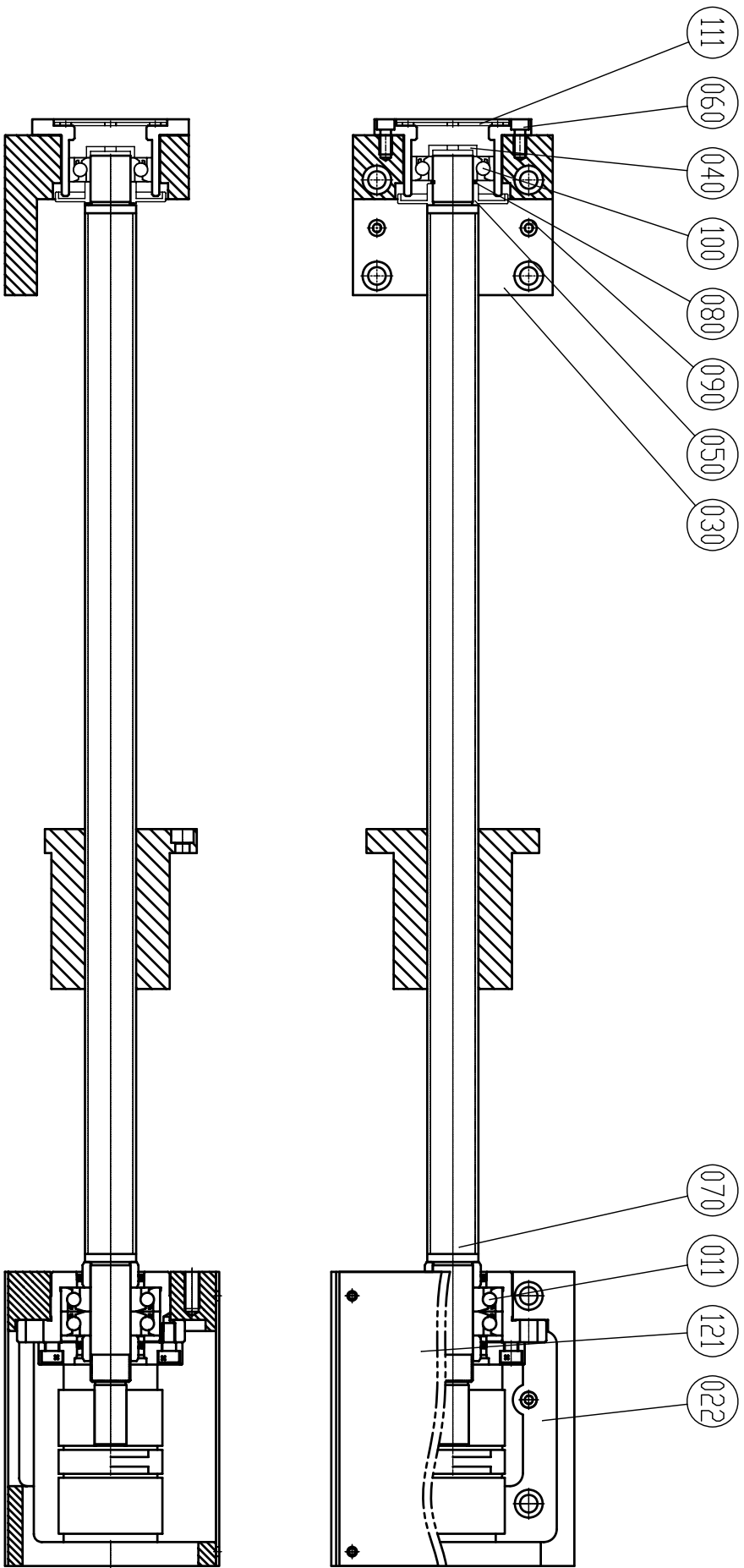

Leaderway Machinery Co. Ltd.

Scale 1:4
 Drawing Name Z軸傳動單元
 Z AXIS TRANSMISSION UNIT
 Page 1/1 A4

Drawn Name 張靜宜	Date 99.02.01	Draw No. 8120089C0 (2F23002)
Control		

台灣力得衛宇龍科技股份有限公司

*單階材料用量清單

製表日期: 099-09-08

第1頁

主作品號	序號	元作品號	品名 英文品名	規 格	月量
2F50009			外型護罩單元 ENCLOSURE GUARD UNIT	V33i	
	0014	3581205F0	大護罩 LARGE COVER	7500\SPCC	1
	0020	3581206B0	左護板 LEFT COVER PLATE	7500\SPCC	1
	0031	3581207C0	右護板 RIGHT COVER PLATE	7500\SPCC	1
	0040	3581208A0	上門輪座 DOOR WHEEL BRACKET	7110\SPCC	2
	0050	4402000628	軸承 BEARING	628ZZ 8*24*8 日本	12
	0063	3581213D0	左前門 (L) FRONT DOOR	7480\SPCC	1
	0070	3560146B0	前門壓克力 ACRYLIC PLATE, FRONT DOOR	4360\ACRY	2
	0080	3560169B0	壓克力壓板 LOCKING PLATE, DOOR ACRYLIC	7120\SPCC	2
	0090	4300460100	管型把手(加高) HANDLE	U1-600L-100H	2
	0102	3520054C0	門輪 DOOR WHEEL	3260\S45C	4
	0110	3520055A0	門輪 DOOR WHEEL	3260\S45C	4
	0120	4060600028	C型扣環(孔用) C TYPE RETAINER RING	R-28	4
	0130	4060700012	C型扣環(軸用) C TYPE RETAINER RING	S-12	4
	0140	4400206001	深槽滾珠軸承 BEARING	6001ZZ 12x28x8	4
	0150	3580024A0	前門下門輪支架 LOWER DOOR WHEEL BRACKET	7110\SPCC	4
	0161	3581215B0	前門擋水板 WATER BAFFLE	7210\SPCC	2
	0173	3581214D0	右前門 (R) FRONT DOOR	7480\SPCC	1
	0180	3581216A0	下門軌 LOWER DOOR GUIDE	7130\SPCC	1
	0192	3582051C0	側門壓克力 ACRYLIC PLATE, SIDE DOOR	4360\ACRY	2
	0201	3500414B0	側門把手座 SIDE DOOR HANDLE BRACKET	7180\SPCC	4
	0210	4090500403	鎖頭 LOCK	C-403(長型)七星小S	4
	0220	4300435100	側門把手(斜背式取手) SIDE DOOR HANDLE	ET-35100(金石門)	4
	0233	3581217D0	右上蓋板 RINGHT SIDE COVER	7210\SPCC	1
	0241	3580037A0	伸臂蓋板 OUTSTRETCHED ARM COVER	7180\SPCC	1
	0254	3581218F0	左後飾板 REAR PLATE	7510\SPCC	1
	0260	3581219B0	電氣箱下飾板 LOWER PLATE	7450\SPCC	1
	0273	3581298A0	前下飾板 LOWER PLATE	7510\SPCC	1
	0280	3582060A0	水槍風槍座 WATER GUN / AIR GUN SEAT	7210\SPCC	1
	0291	3582066B0	右側下飾板 (R) LOWER PLATE	7510\SPCC	1
	0300	3581221A0	左前導屑板 CHIP PLATE	7210\SPCC	1

<續下頁>

台灣力得衛宇龍科技股份有限公司

*單階材料用量清單

製表日期: 099-09-08

第2頁

主件品號	序號	元件品號	品名 英文品名	規 格	月量
2F50009	0310	3581222A0	右前導層板 CHIP PLATE	7210\SPCC	1
	0320	3581235A0	後飾板固定板 REAR FIXED PLATE	7210\SPCC	1
	0330	4720700001	工作燈 WORKING LIGHT	GENP-24V-70W	1
	0340	3580089A0	工作燈座 WORKING LIGHT BRACKET	7210\SPCC	1
	0362	3582087C0	油冷機門 DOOR OF OIL COOLER	7510\2t SPCC	1
	0380	3581261A0	護罩前飾條 RUBBER RIBBON, TELESCOPIC BA	4510\SUS303	1
	0390	3580239A0	側窗飾條 RUBBER RIBBON	4510\SUS303	2
	0400	3581295A0	前門定位板 ORIENTATION PLATE	7210\SPCC	2
	0410	4300421602	門扣把手 DOOR LOCK	B-010長軸(六角型)+B-1602(取	1
	0420	4300401024	門扣把手檔板 DOOR LOCK PLATE	B-01024	1

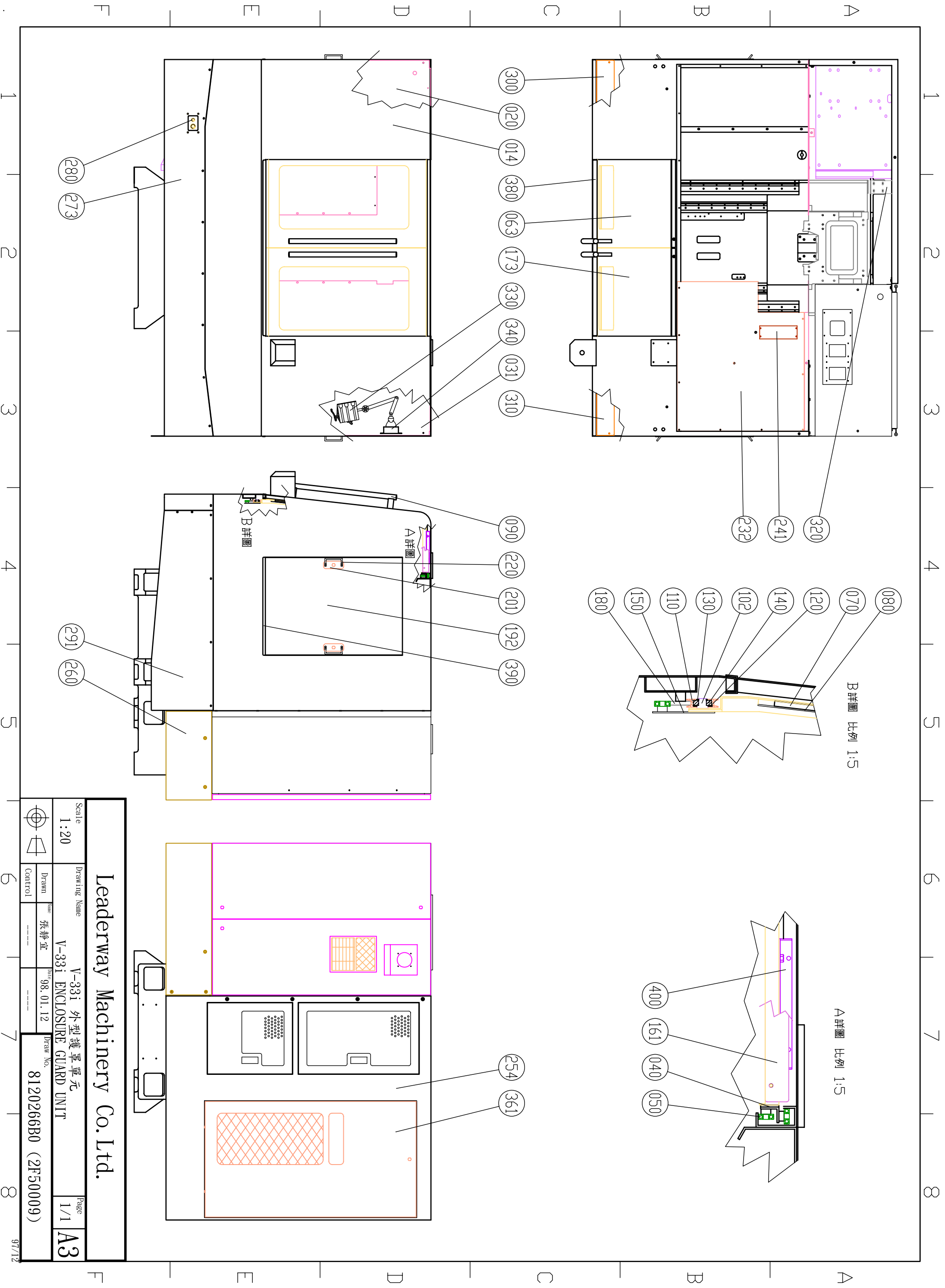

B 詳圖 比例 1:5

A 詳圖 比例 1:5

Leaderway Machinery Co. Ltd.

Scale 1:20		Drawing Name V-33i 外型護罩單元 V-33i ENCLOSURE GUARD UNIT		Page 1/1
Drawn Control	Name 張靜宜	Date 98.01.12	Draw No. 8120266B0 (2F50009)	Page A3

台灣力得衛宇龍科技股份有限公司

*單階材料用量清單

製表日期: 099-09-08

第1頁

主件品號	序號	元件品號	品名 英文品名	規 格	月量
2F50010			外型護罩單元 ENCLOSURE GUARD UNIT	V42i	
	0015	3582044G0	大護罩 LARGE COVER	7500\SPCC	1
	0021	3582045C0	左後板 REAR PLATE	7510\SPCC	1
	0030	3582046B0	右護板 RIGHT COVER PLATE	7500\SPCC	1
	0043	3582047E0	左前門 (L) FRONT DOOR	7480\SPCC	1
	0053	3582048E0	右前門 (R) FRONT DOOR	7480\SPCC	1
	0060	3580024A0	前門下門輪支架 LOWER DOOR WHEEL BRACKET	7110\SPCC	4
	0072	3520054C0	門輪 DOOR WHEEL	3260\S45C	4
	0080	3520055A0	門輪 DOOR WHEEL	3260\S45C	4
	0090	4060600028	C型扣環(孔用) C TYPE RETAINER RING	R-28	4
	0100	4060700012	C型扣環(軸用) C TYPE RETAINER RING	S-12	4
	0110	4400206001	深槽滾珠軸承 BEARING	6001ZZ 12x28x8	4
	0120	4300460100	管型把手(加高) HANDLE	U1-600L-100H	2
	0130	3560146B0	前門壓克力 ACRYLIC PLATE, FRONT DOOR	4360\ACRY	2
	0140	3560169B0	壓克力壓板 LOCKING PLATE, DOOR ACRYLIC	7120\SPCC	2
	0150	3582049A0	上門輪座 DOOR WHEEL BRACKET	7110\SPCC	2
	0160	4402000628	軸承 BEARING	628ZZ 8*24*8 日本	12
	0170	3582050A0	下門軌 LOWER DOOR GUIDE	7130\SPCC	1
	0182	3582051C0	側門壓克力 ACRYLIC PLATE, SIDE DOOR	4360\ACRY	2
	0191	3500414B0	側門把手座 SIDE DOOR HANDLE BRACKET	7180\SPCC	4
	0200	4090500403	鎖頭 LOCK	C-403(長型)七星小S	4
	0210	4300435100	側門把手(斜背式取手) SIDE DOOR HANDLE	ET-35100(金石門)	4
	0223	3582054D0	右上蓋板 RINGHT SIDE COVER	7510\SPCC	1
	0231	3580037A0	伸臂蓋板 OUTSTRETCHED ARM COVER	7180\SPCC	1
	0244	3582056F0	左後飾板 REAR PLATE	7510\SPCC	1
	0250	3582057B0	右側後飾板 REAR PLATE	7510\SPCC	1
	0260	3582058B0	電氣箱下飾板 LOWER PLATE	7450\SPCC	1
	0272	3582059C0	前下飾板 LOWER PLATE	7510\SPCC	1
	0280	3582060A0	水槍風槍座 WATER GUN / AIR GUN SEAT	7210\SPCC	1
	0291	3582066B0	右側下飾板 (R) LOWER PLATE	7510\SPCC	1
	0300	3582052A0	左前導屑板 CHIP PLATE	7210\SPCC	1

<續下頁>

台灣力得衛宇龍科技股份有限公司

*單階材料用量清單

製表日期: 099-09-08

第2頁

主件品號	序號	元件品號	品名 英文品名	規 格	月量
2F50010	0310	3582053A0	右前導層板 CHIP PLATE	7210\SPCC	1
	0320	3581235A0	後飾板固定板 REAR FIXED PLATE	7210\SPCC	1
	0331	3581215B0	前門擋水板 WATER BAFFLE	7210\SPCC	2
	0340	4720700001	工作燈 WORKING LIGHT	GENP-24V-70W	1
	0350	3580089A0	工作燈座 WORKING LIGHT BRACKET	7210\SPCC	1
	0380	3581246A0	右側飾板角鐵 ANGLE OF PLATE	7210\SPCC	1
	0392	3582087C0	油冷機門 DOOR OF OIL COOLER	7510\2t SPCC	1
	0410	3582106A0	護罩前飾條 RUBBER RIBBON, TELESCOPIC BA	4510\SUS303	1
	0420	3580239A0	側窗飾條 RUBBER RIBBON	4510\SUS303	2
	0430	3581295A0	前門定位板 ORIENTATION PLATE	7210\SPCC	2
	0440	4300421602	門扣把手 DOOR LOCK	B-010長軸(六角型)+B-1602(取	1
	0450	4300401024	門扣把手檔板 DOOR LOCK PLATE	B-01024	1

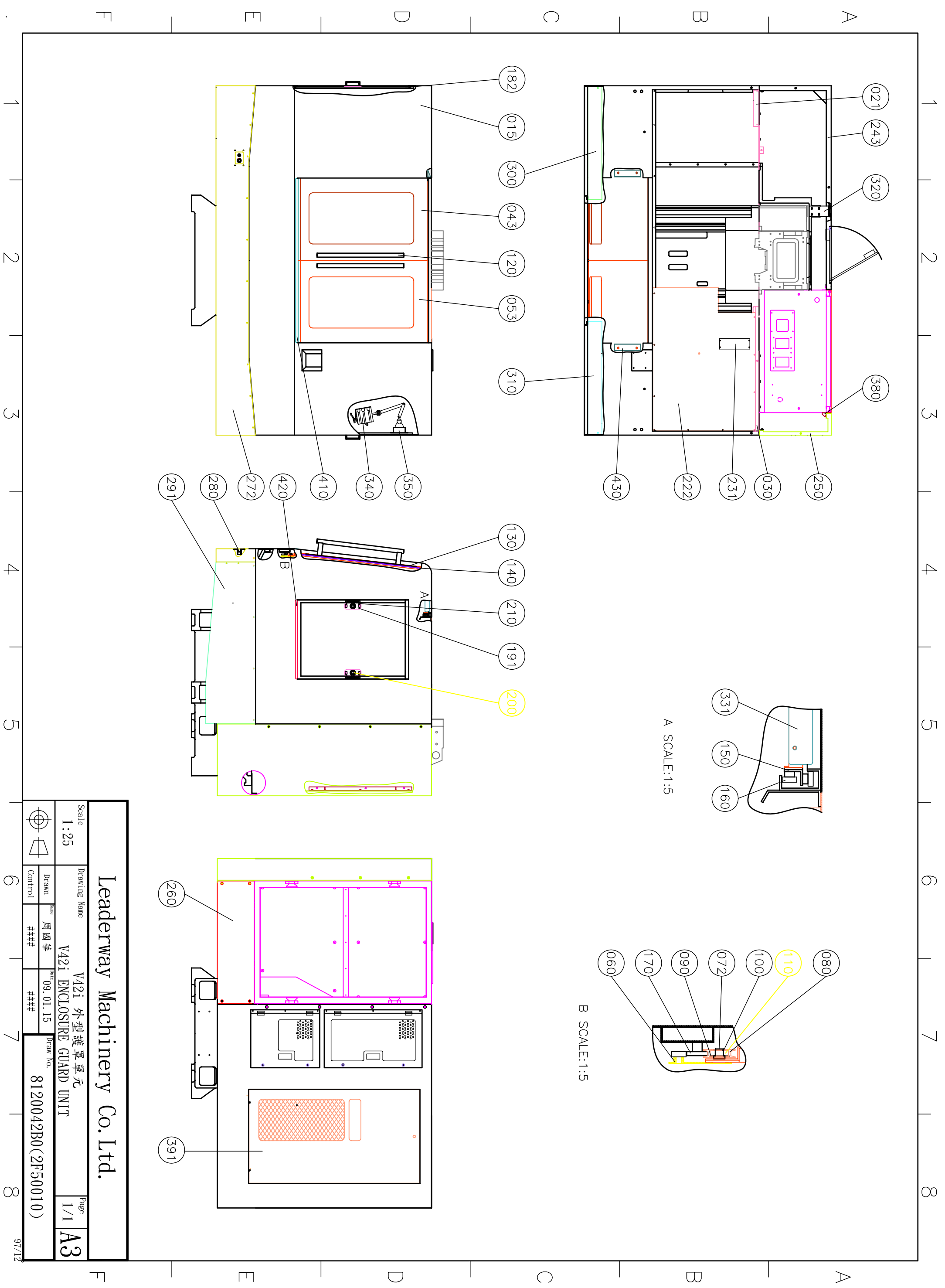

Leaderway Machinery Co. Ltd.

Scale		Drawing Name		Page	
1:25		V42i 外型護罩單元		1/1	
Drawn		V42i ENCLOSURE GUARD UNIT		A3	
Control		周國華		8120042B0(2F50010)	
		Date: 09.01.15		Draw No.	
		###		###	

台灣力得衛宇龍科技股份有限公司

*單階材料用量清單

製表日期: 099-09-08

第1頁

主件品號	序號	元件品號	品名 英文品名	規 格	月量
2F51008			水箱單元(螺旋式排屑) COOLANT TANK UNIT(COIL TYPE)	V33i	
	0014	3582067E0	導屑槽(螺旋式) CHIP TRAUGH	7520\SPCC	1
	0020	3581227A0	螺旋捲屑器 CHIP CONVEYOR	9570	1
	0030	4440800015	排屑器馬達 CONVEYOR MOTOR	1/4HP 1:100 FME22	1
	0041	3581228B0	排屑炮管(附蓋及防漏膠墊) CHIP THROUGH TUBE	7570\SPCC	1
	0055	3581225F0	水箱 COOLANT TANK	7580\SPCC	1
	0070	4510100001	油表 COOLANT LEVEL GAUGE	3''	1
	0080	4300401421	把手(染黑) HAHDLE	A-42-A	2
	0093	3581226E0	水箱蓋 COOLANT TANK COVER	7580\SPCC	1
	0110	4430040303	切削液泵浦(直立式) COOLANT PUMP	TPHK4T3-2S	1
	0134	3581304B0	水箱遮水板 DASH BOARD	7180\SPCC	1
	0140	4530012424	水用電磁閥KSD SOLENOID VALVE	JB4K-24V(1/2")	2
	0150	3500428A0	管接頭座 CONNECTOR BRACKET	3150\S45C	1
	0241	3582107B0	蓄屑盤 CHIP PLATE	7520\SPCC	1
	0252	3582103C0	蓄屑槽 FILTER NET	7590\SPCC	1
	0261	3581303A0	過濾擋水板 WATER BAFFLE	7210\SPCC	1

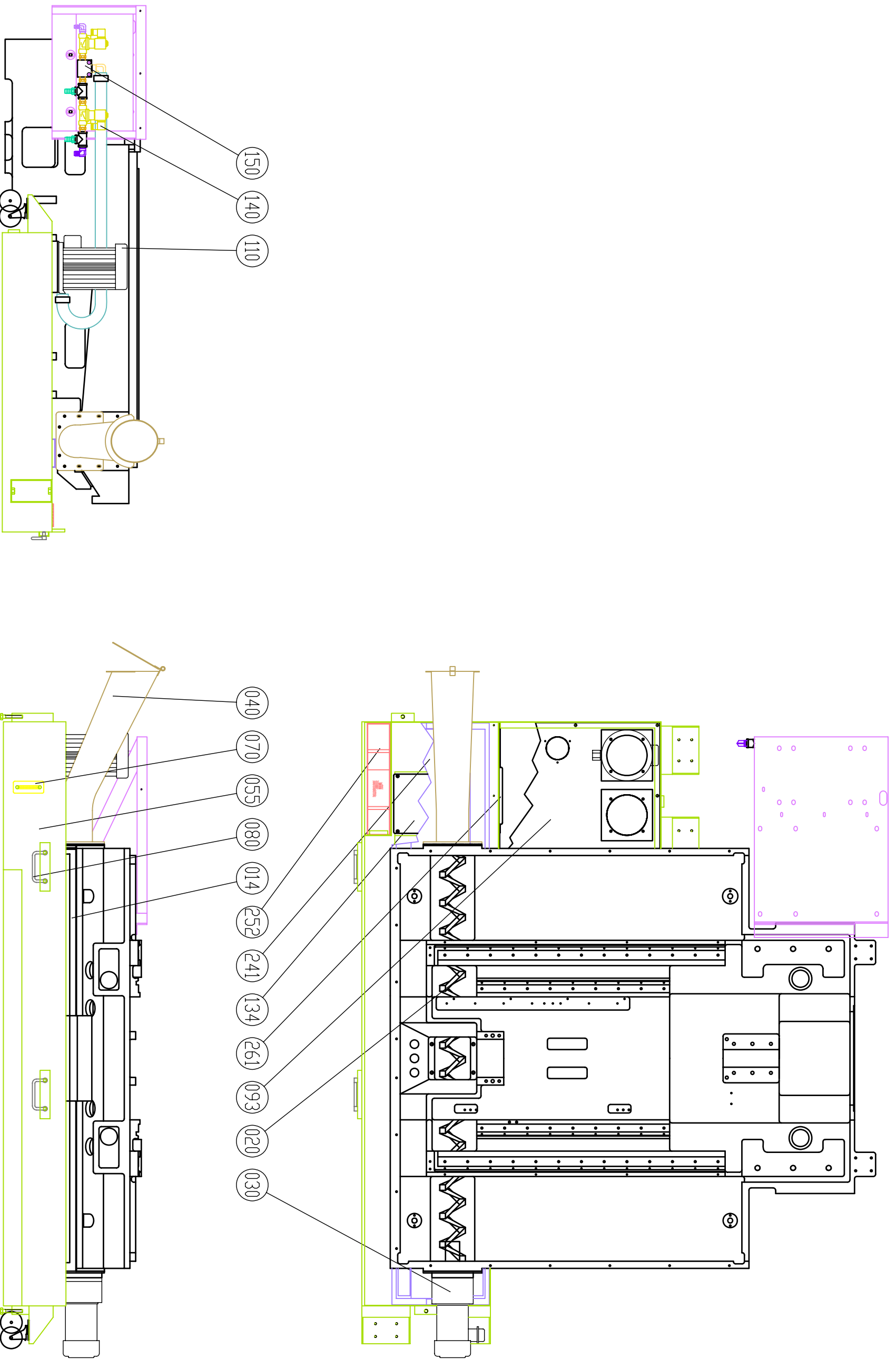

Leaderway Machinery Co. Ltd.

Scale		Drawing Name		Page	
1:14		V-33i 水箱單元 (螺旋式排屑)		1/1	
Drawn	Control	Name	Date	Draw No.	
		張靜宜	97.11.12	8120234B0 (2F51008)	

台灣力得衛宇龍科技股份有限公司

*單階材料用量清單

製表日期: 099-09-08

第1頁

主件品號	序號	元件品號	品名 英文品名	規 格	月量
2F51009			水箱單元(螺旋式排屑) COOLANT TANK UNIT(COIL TYPE)	V42i	
	0014	3582067E0	導屑槽(螺旋式) CHIP TRAUGH	7520\SPCC	1
	0021	3582068B0	螺旋捲屑器 CHIP CONVEYOR	9570	1
	0030	4440800015	排屑器馬達 CONVEYOR MOTOR	1/4HP 1:100 FME22	1
	0041	3582069B0	排屑炮管(附蓋及防漏膠墊) CHIP THROUGH TUBE	7570\SPCC	1
	0054	3582072E0	水箱 COOLANT TANK	7580\SPCC	1
	0070	4510100001	油表 COOLANT LEVEL GAUGE	3''	1
	0080	4300401421	把手(染黑) HAHDLE	A-42-A	2
	0093	3582073E0	水箱蓋 COOLANT TANK COVER	7510\SPCC	1
	0110	4430040303	切削液泵浦(直立式) COOLANT PUMP	TPHK4T3-2S	1
	0133	3582125A0	過濾擋水板 WATER BAFFLE	7210\SPCC	1
	0140	4530012424	水用電磁閥KSD SOLENOID VALVE	JB4K-24V(1/2")	2
	0150	3500428A0	管接頭座 CONNECTOR BRACKET	3150\S45C	1
	0241	3582102B0	蓄屑盤 CHIP PLATE	7520\SPCC	1
	0252	3582103C0	蓄屑槽 FILTER NET	7590\SPCC	1
	0262	3581304B0	水箱遮水板 DASH BOARD	7180\SPCC	1

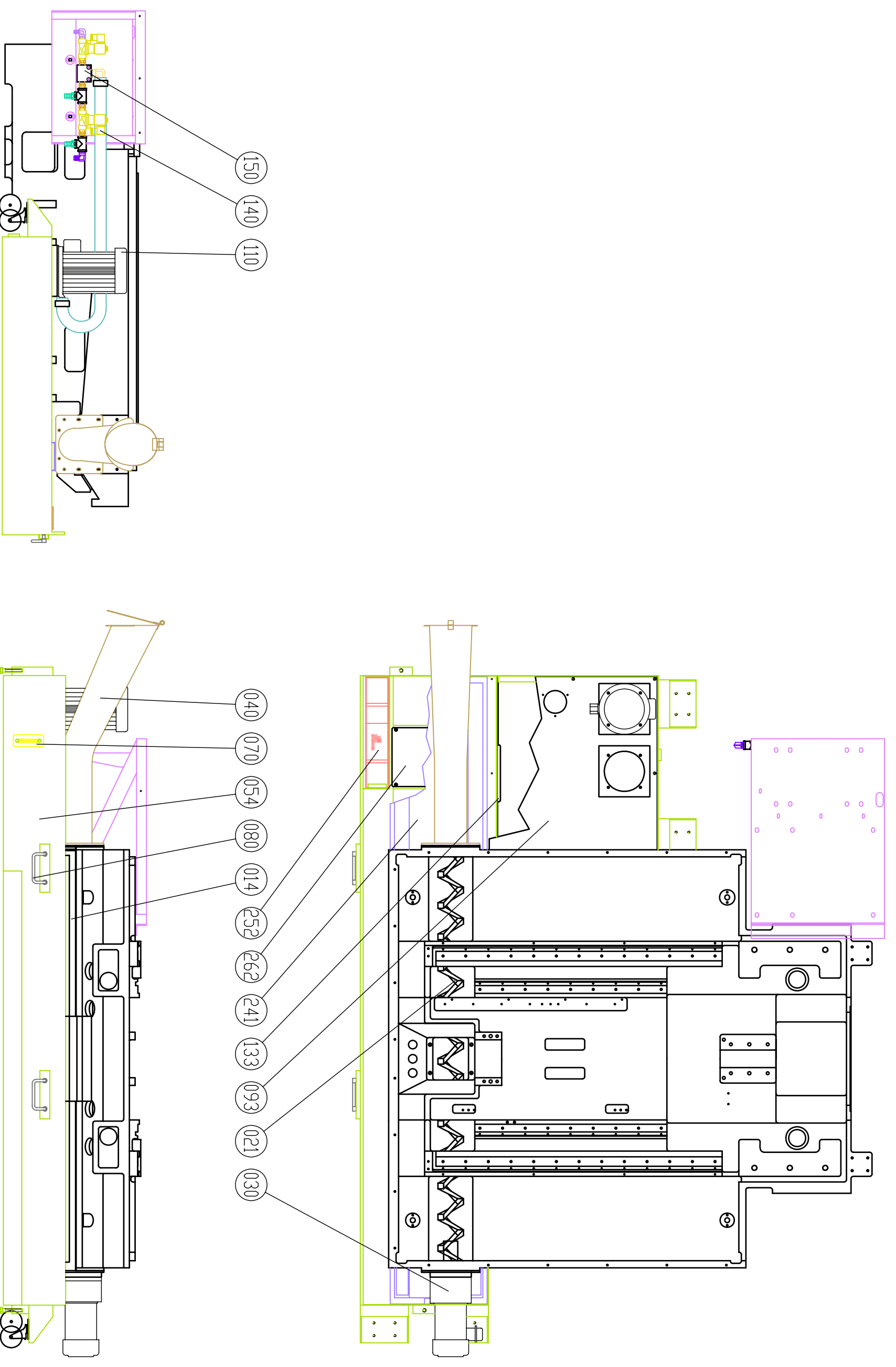

Leaderway Machinery Co. Ltd.

Scale		Drawing Name		Page	
1:14		V-42i 水箱單元 (螺旋式排屑)		1/1	
Drawn		Name		Draw No.	
Control		張靜宜		8120235B0 (2F51009)	
		Date			
		97.11.11			

台灣力得衛宇龍科技股份有限公司

*單階材料用量清單

製表日期: 099-09-08

第1頁

主件品號	序號	元件品號	品名 英文品名	規 格	月量
2F51025			水箱單元(龍船式) COOLANT UNIT (CHAIN TYPE CHI	V33i	
	0013	3581224E0	龍船式排屑機 CHIP CONVEYOR	9940\SPCC	1
	0023	3581225F0	水箱 COOLANT TANK	7580\SPCC	1
	0030	4510100001	油表 COOLANT LEVEL GAUGE	3''	1
	0040	4300401421	把手(染黑) HAHDLE	A-42-A	2
	0051	3582103C0	蓄屑槽 FILTER NET	7590\SPCC	1
	0062	3581226E0	水箱蓋 COOLANT TANK COVER	7580\SPCC	1
	0071	3581303A0	過濾擋水板 WATER BAFFLE	7210\SPCC	1
	0083	3581304B0	水箱遮水板 DASH BOARD	7180\SPCC	1
	0090	4430040303	切削液泵浦(直立式) COOLANT PUMP	TPHK4T3-2S	1
	0100	4530012424	水用電磁閥KSD SOLENOID VALVE	JB4K-24V(1/2")	2
	0110	3500428A0	管接頭座 CONNECTOR BRACKET	3150\S45C	1

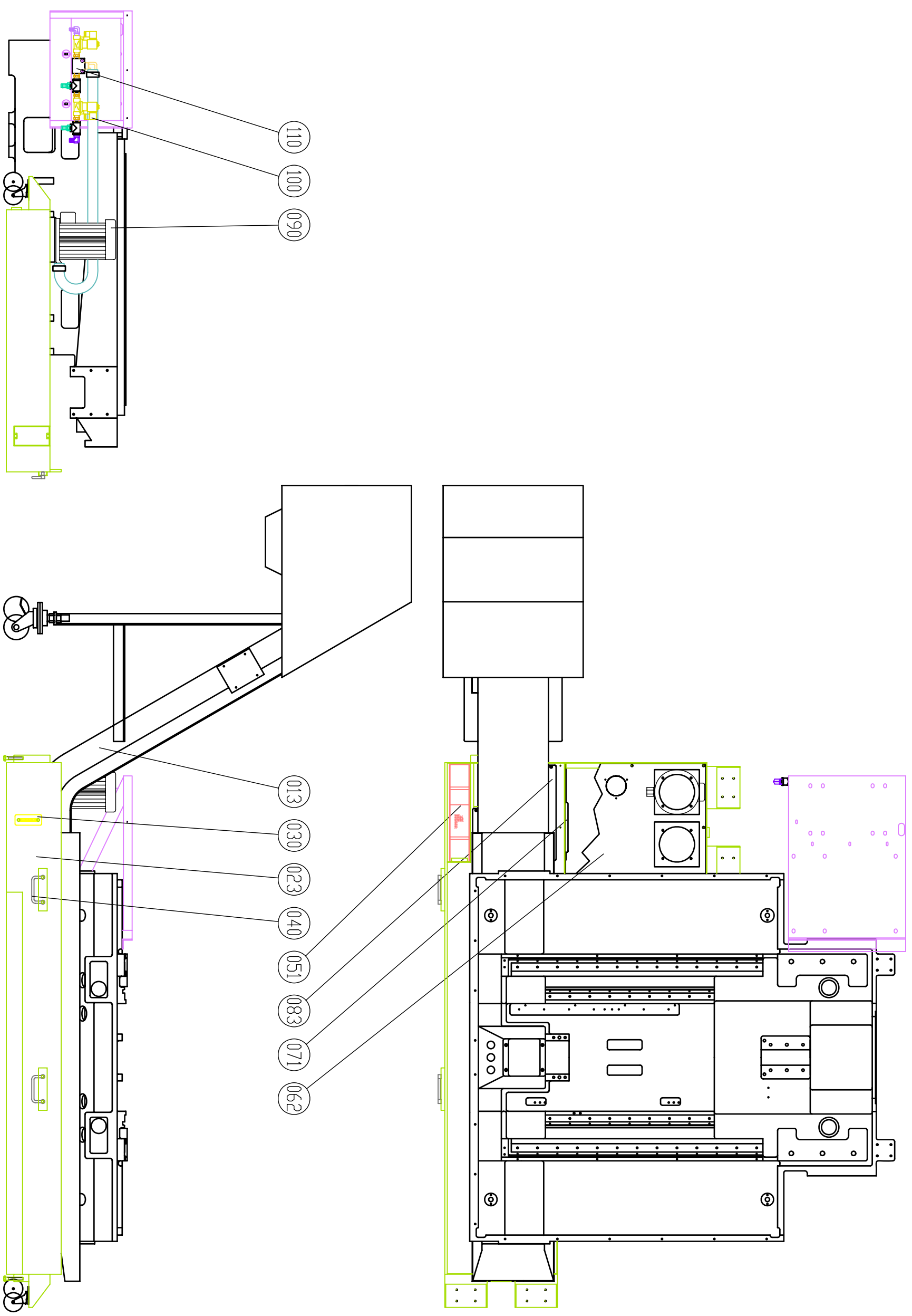

Leaderway Machinery Co. Ltd.

Scale		Drawing Name		Page	
1:16		V-33i 水箱單元 (龍船式排屑)		1/1	
Drawn		V-33i COOLANT UNIT (CHAIN TYPE CHIP CONVEYOR)		A3	
Control		張靜宜		8120260B0 (2F51025)	
		Date		Draw No.	
		97.11.12			

台灣力得衛宇龍科技股份有限公司

*單階材料用量清單

製表日期: 099-09-08

第1頁

主件品號	序號	元件品號	品名 英文品名	規 格	月量
2F51028			水箱單元(龍船式) COOLANT UNIT (CHAIN TYPE CHI	V42i	
	0011	3582126B0	龍船式排屑機 CHIP CONVEYOR	9940\SPCC	1
	0021	3582072E0	水箱 COOLANT TANK	7580\SPCC	1
	0030	4510100001	油表 COOLANT LEVEL GAUGE	3''	1
	0040	4300401421	把手(染黑) HAHDLE	A-42-A	2
	0050	3582103C0	蓄屑槽 FILTER NET	7590\SPCC	1
	0061	3582073E0	水箱蓋 COOLANT TANK COVER	7510\SPCC	1
	0070	3582125A0	過濾擋水板 WATER BAFFLE	7210\SPCC	1
	0081	3581304B0	水箱遮水板 DASH BOARD	7180\SPCC	1
	0090	4430040303	切削液泵浦(直立式) COOLANT PUMP	TPHK4T3-2S	1
	0100	4530012424	水用電磁閥KSD SOLENOID VALVE	JB4K-24V(1/2")	2
	0110	3500428A0	管接頭座 CONNECTOR BRACKET	3150\S45C	1

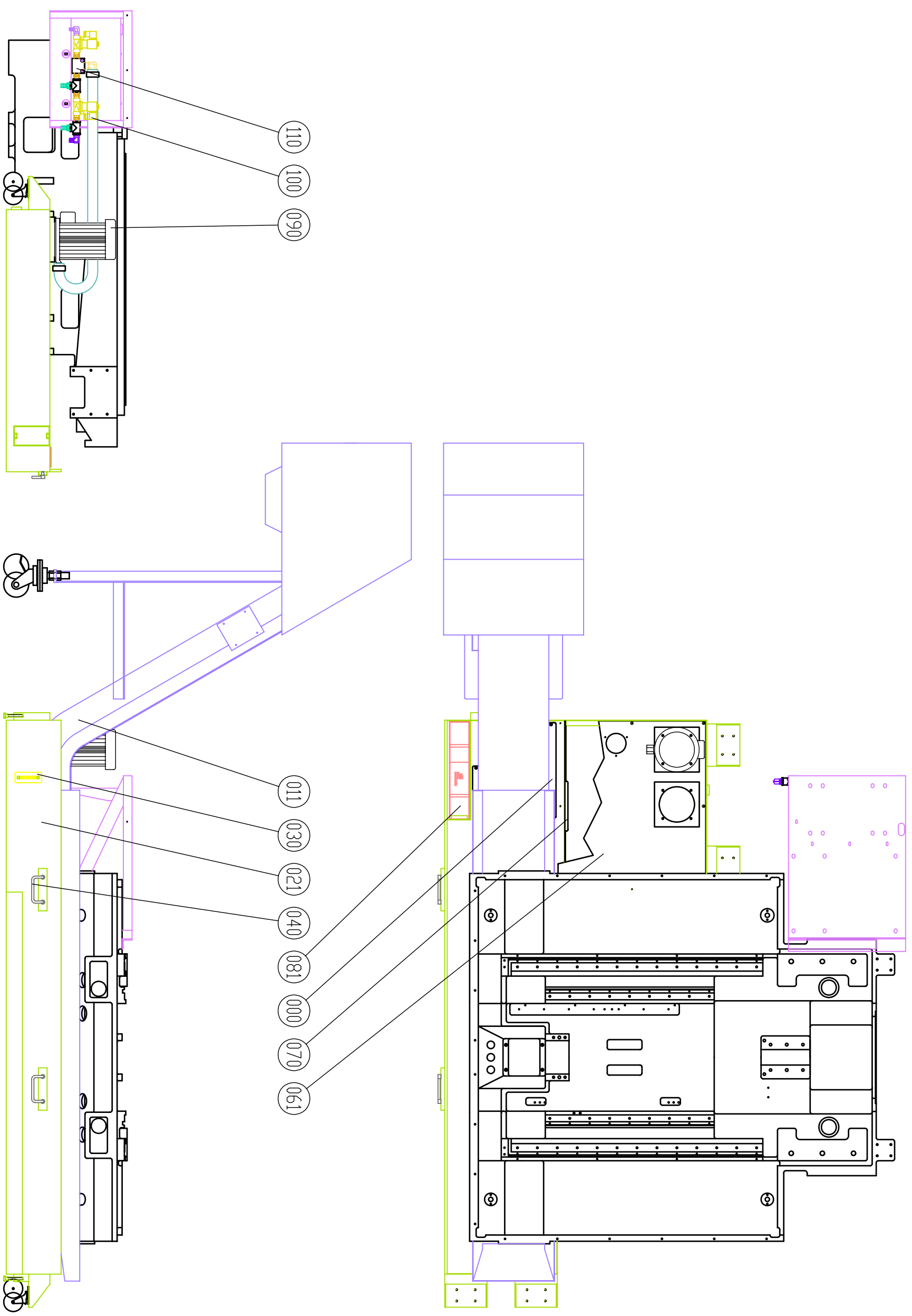

A
B
C
D
E
F

1
2
3
4
5
6
7
8

A
B
C
D
E
F

1
2
3
4
5
6
7
8

台灣力得衛宇龍科技股份有限公司

*單階材料用量清單

製表日期: 099-09-08

第1頁

主件品號	序號	元件品號	品名 英文品名	規 格	月量
2F51023			水箱單元(直型炮管) COOLANT TANK UNIT	V33i	
	0010	3581284A0	導屑槽(螺旋式) CHIP TRAUGH	7520\SPCC	1
	0020	3581227A0	螺旋捲屑器 CHIP CONVEYOR	9570	1
	0030	4440800015	排屑器馬達 CONVEYOR MOTOR	1/4HP 1:100 FME22	1
	0040	3581271A0	直型炮管(附防漏膠墊) CHIP THROUGH TUBE	7570\SPCC	1
	0050	3581267A0	水箱 COOLANT TANK	7580\SPCC	1
	0060	4510100001	油表 COOLANT LEVEL GAUGE	3''	1
	0070	3581269A0	水箱蓋(一) COOLANT TANK COVER(1)	7510\SPCC	1
	0080	3581270A0	水箱蓋(二) COOLANT TANK COVER(2)	7510\SPCC	1
	0090	4430040303	切削液泵浦(直立式) COOLANT PUMP	TPHK4T3-2S	2
	0100	3581268A0	泵浦固定板 PUMP BRACKET	7180\SPCC	1
	0190	3581285A0	蓄屑槽 FILTER NET	7590\SPCC	1
	0200	3581286A0	蓄屑槽蓋 FILTER NET COVER	7550\SPCC	1
	0210	3500428A0	管接頭座 CONNECTOR BRACKET	3150\S45C	1
	0220	4530012424	水用電磁閥KSD SOLENOID VALVE	JB4K-24V(1/2")	2

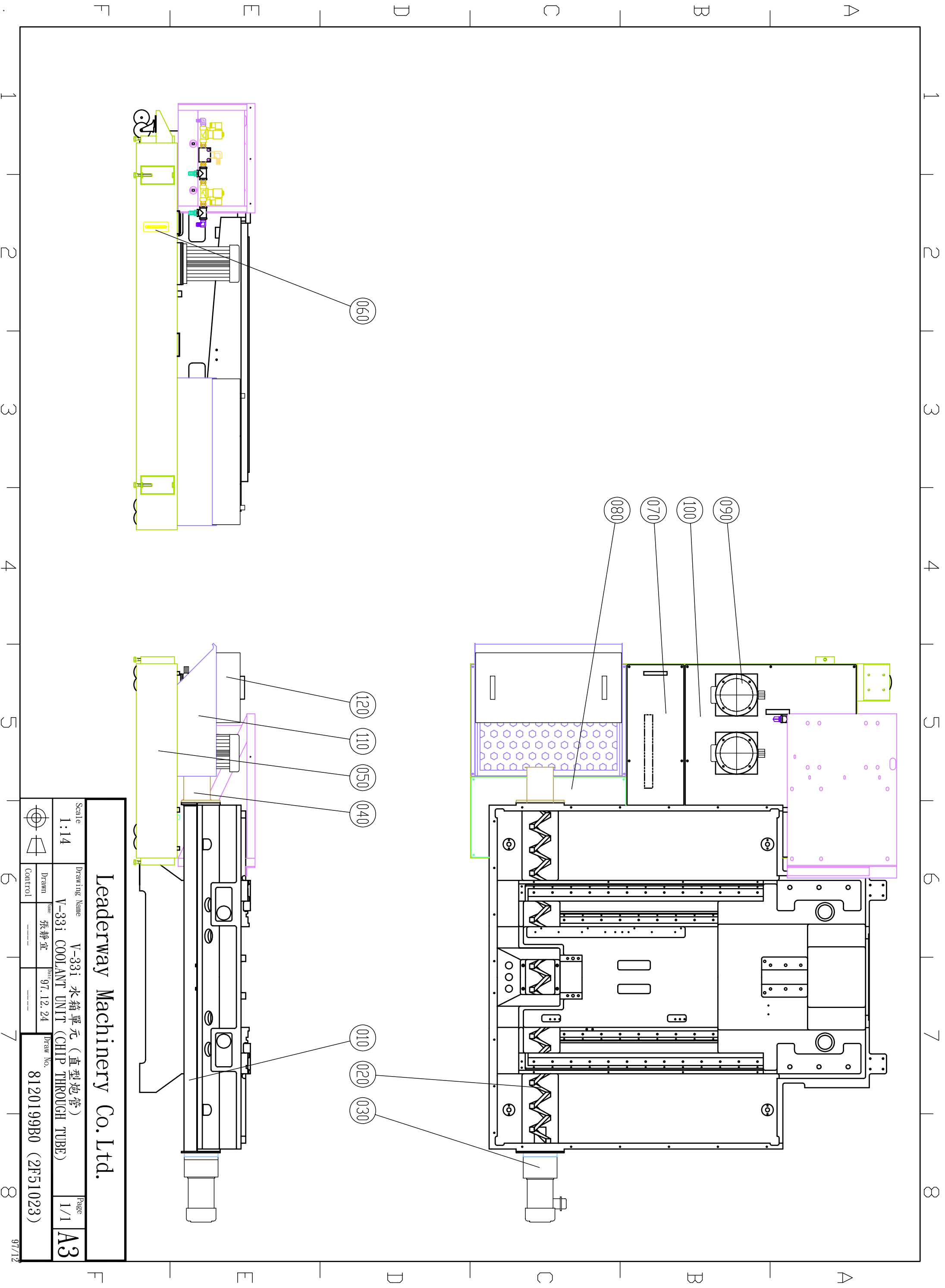

Leaderway Machinery Co. Ltd.

Scale		Drawing Name		Page	
1:14		V-33i 水箱單元 (直型炮管)		1/1	
Drawn		V-33i COOLANT UNIT (CHIP THROUGH TUBE)		A3	
Control		Date: 97.12.24		Draw No.	
		張靜宜		8120199B0 (2F51023)	

台灣力得衛宇龍科技股份有限公司

*單階材料用量清單

製表日期: 099-09-08

第1頁

主件品號	序號	元件品號	品名 英文品名	規 格	月量
2F51033			水箱單元(直型炮管) COOLANT TANK UNIT	V42i	
	0010	3581284A0	導屑槽(螺旋式) CHIP TRAUGH	7520\SPCC	1
	0020	3582068B0	螺旋捲屑器 CHIP CONVEYOR	9570	1
	0030	4440800015	排屑器馬達 CONVEYOR MOTOR	1/4HP 1:100 FME22	1
	0040	3582136A0	直型炮管(附防漏膠墊) CHIP THROUGH TUBE	7570\SPCC	1
	0050	3582137A0	水箱 COOLANT TANK	7580\SPCC	1
	0060	4510100001	油表 COOLANT LEVEL GAUGE	3''	1
	0070	3582138A0	水箱蓋(一) COOLANT TANK COVER	7510\SPCC	1
	0080	3582139A0	水箱蓋(二) COOLANT TANK COVER	7510\SPCC	1
	0090	4430040303	切削液泵浦(直立式) COOLANT PUMP	TPHK4T3-2S	2
	0100	3582140A0	泵浦固定板 PUMP BRACKET	7180\SPCC	1
	0110	3581285A0	蓄屑槽 FILTER NET	7590\SPCC	1
	0120	3581286A0	蓄屑槽蓋 FILTER NET COVER	7550\SPCC	1
	0130	3500428A0	管接頭座 CONNECTOR BRACKET	3150\S45C	1
	0140	4530012424	水用電磁閥KSD SOLENOID VALVE	JB4K-24V(1/2")	2

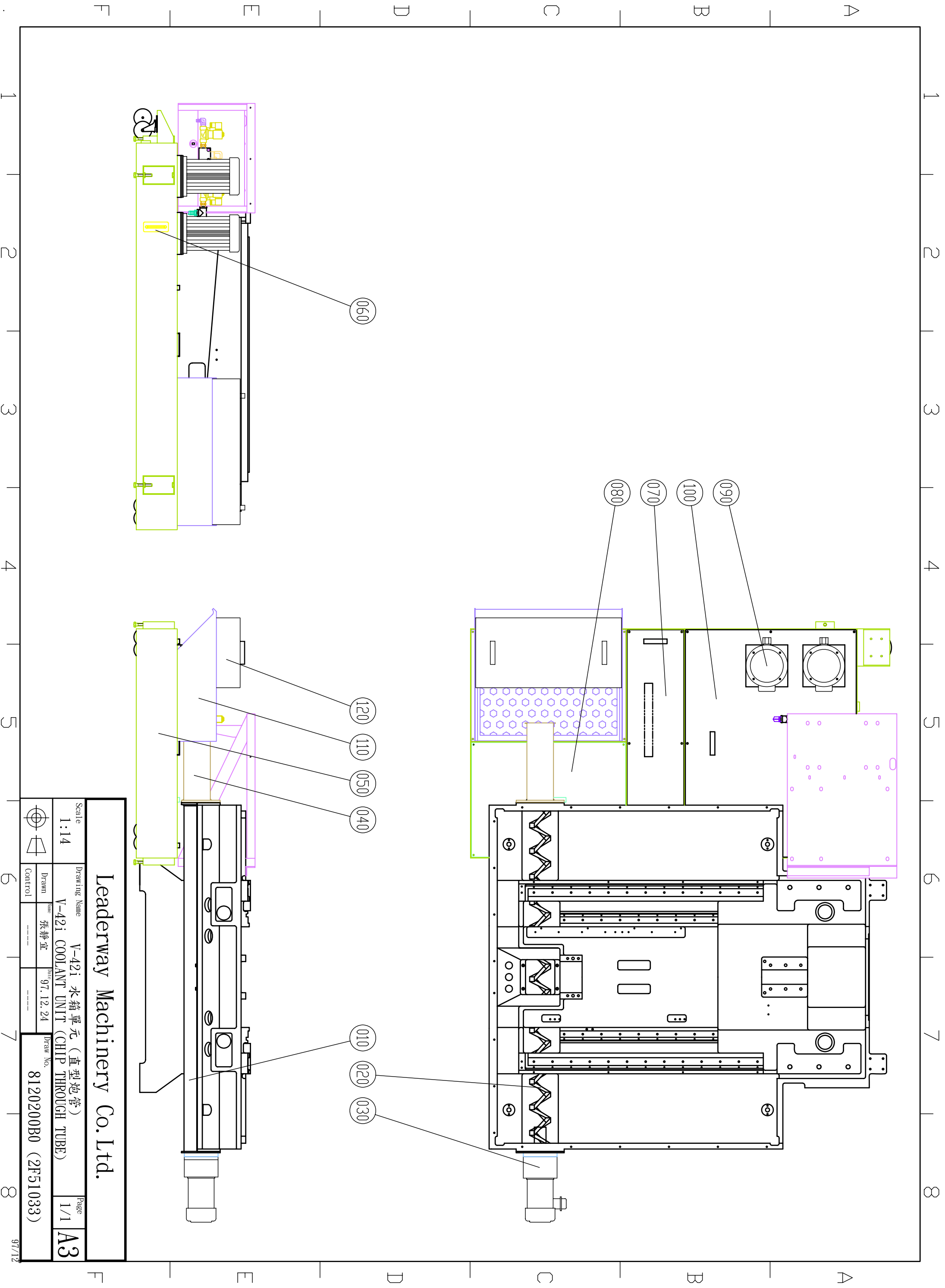

Leaderway Machinery Co. Ltd.

Scale		Drawing Name		Page	
1:14		V-42i 水箱單元 (直型炮管)		1/1	
Drawn	Name	V-42i COOLANT UNIT (CHIP THROUGH TUBE)		A3	
Control	張靜宜	Date	97.12.24	Draw No.	
				8120200B0 (2F51033)	

台灣力得衛宇龍科技股份有限公司

*單階材料用量清單

製表日期: 099-09-08

第1頁

主作品號	序號	元作品號	品名 英文品名	規 格	月量
2F52004			電氣箱單元 POWER CABINET UNIT	V33i/V42i	
	0016	3582019I0	電氣箱 POWER CABINET	7450\SPCC	1
	0020	3581201A0	電氣箱上蓋板 UPPER COVER, POWER CABINET	7450\SPCC	1
	0030	3582020A0	電氣箱左門 (L) DOOR, POWER CABINET	7450\SPCC	1
	0041	3582021B0	電氣箱右門 (R) DOOR, POWER CABINET	7450\SPCC	1
	0050	3582027B0	電氣箱架 POWER CABINET BRACKET	7450\SPCC	1
	0060	4090500403	鎖頭 LOCK	C-403(長型)七星小S	3
	0071	3582030D0	連動管固定座(電) CONDUIT BRACKET	7210\SPCC	1
	0081	3582031C0	聯動管固定座蓋板 CONDUIT BRACKET COVER	7210\SPCC	1
	0090	3500149B0	主電源開關座 MAIN POWER SWITCH BRACKET	7160\SPCC	1
	0101	3500150C0	左右調整座 ADJUSTABLE BRACKET	7160\SPCC	1
	0112	3581204D0	電磁閥配置板 VALVE BRACKET	7210\SPCC	1
	0120	4560300010	熱交換器 HEAT EXCHANGER	HPW-10AR/EA-2A	1

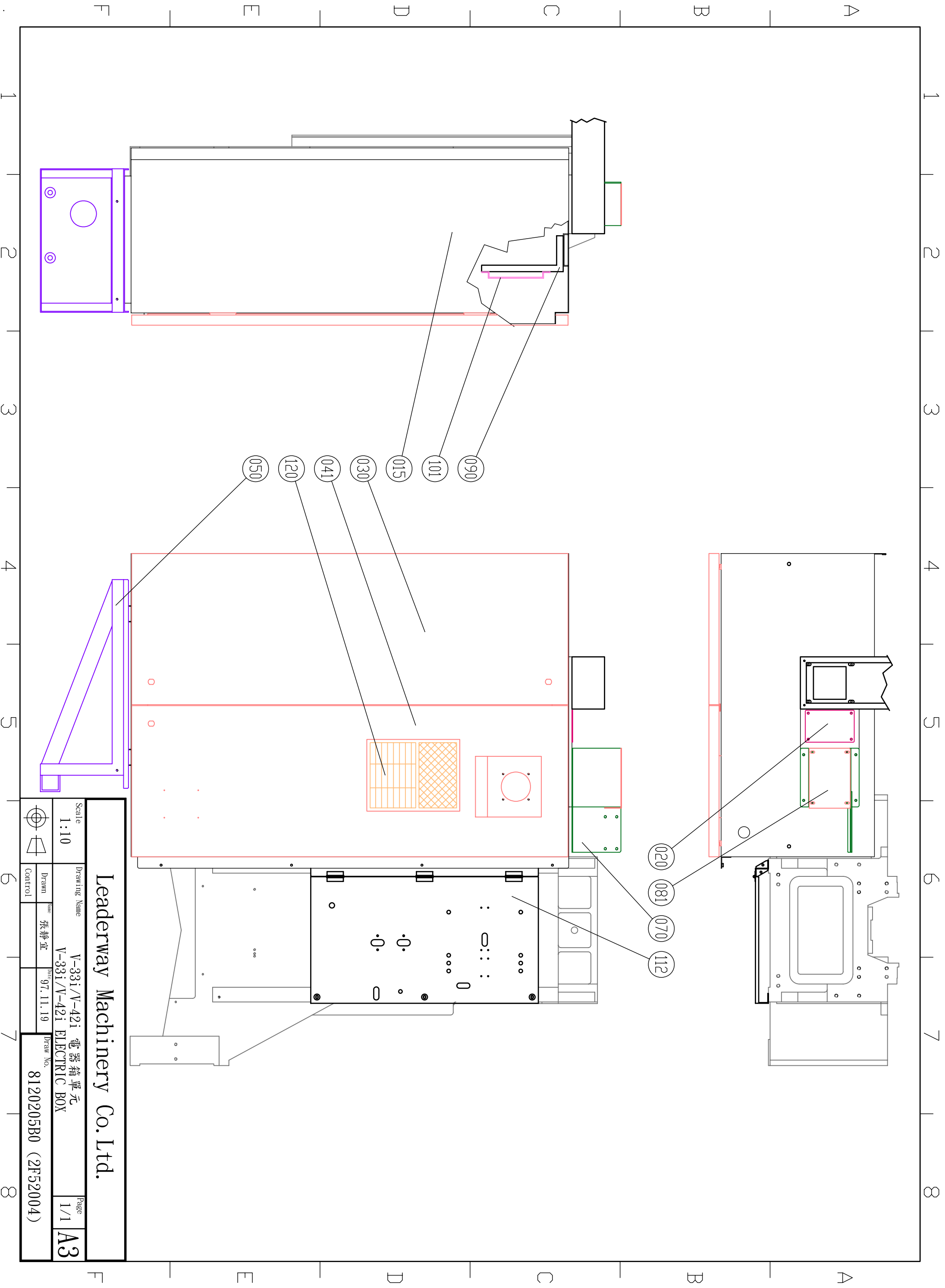

Leaderway Machinery Co. Ltd.

Scale		Drawing Name		Page	
1:10		V-33i/V-42i 電器箱單元 V-33i/V-42i ELECTRIC BOX		1/1	
Drawn	Name	Date	Draw No.	A3	
Control	張靜宜	97.11.19	8120205B0 (2F52004)		

台灣力得衛宇龍科技股份有限公司

*單階材料用量清單

製表日期: 099-09-08

第4頁

主件品號	序號	元件品號	品名 英文品名	規 格	月量
2F53009			操作箱單元 F 0i-MC/PB OPERATION CABINET UNIT	V33i/V42i	
	0015	3582022H0	I/O基板(上) I/O BOARD	7560\SPCCZ	1
	0023	3582023E0	I/O基板 I/O BOARD	7560\SPCCZ	1
	0030	3582026A0	驅動器固定架(0i MC) FIXED BRACKET, DRIVER	7560\SPCCZ	1
	0043	3582032F0	線槽 CONDUIT	7530\SPCC	1
	0050	3582033A0	線槽蓋板 CONDUIT COVER	7540\SPCC	1
	0060	3582034A0	第四軸蓋板(槽) 4TH GUARD COVER	7540\SPCC	1
	0070	3500129A0	旋轉座 ROTATION BRACKET	3240\S45C	1
	0080	3581087C0	轉接板 CONNECTOR BOARD	3230\SS41	1
	0093	3582036F0	操作箱(FANUC 0iMC) OPERATION CABINET	7460\SPCC	1
	0101	3581081D0	操作箱後蓋板 CABINET REAR COVER	7460\SPCC	1
	0110	3582037A0	操作箱下固定座 SHIPPING BRACKET	7460\SPCC	1
	0121	4720632243	警示燈(三層) WARNING LIGHT	GSL-24V-3-B	1
	0130	4300400400	管型把手(自然色) HAHDLE	U1-400L	1

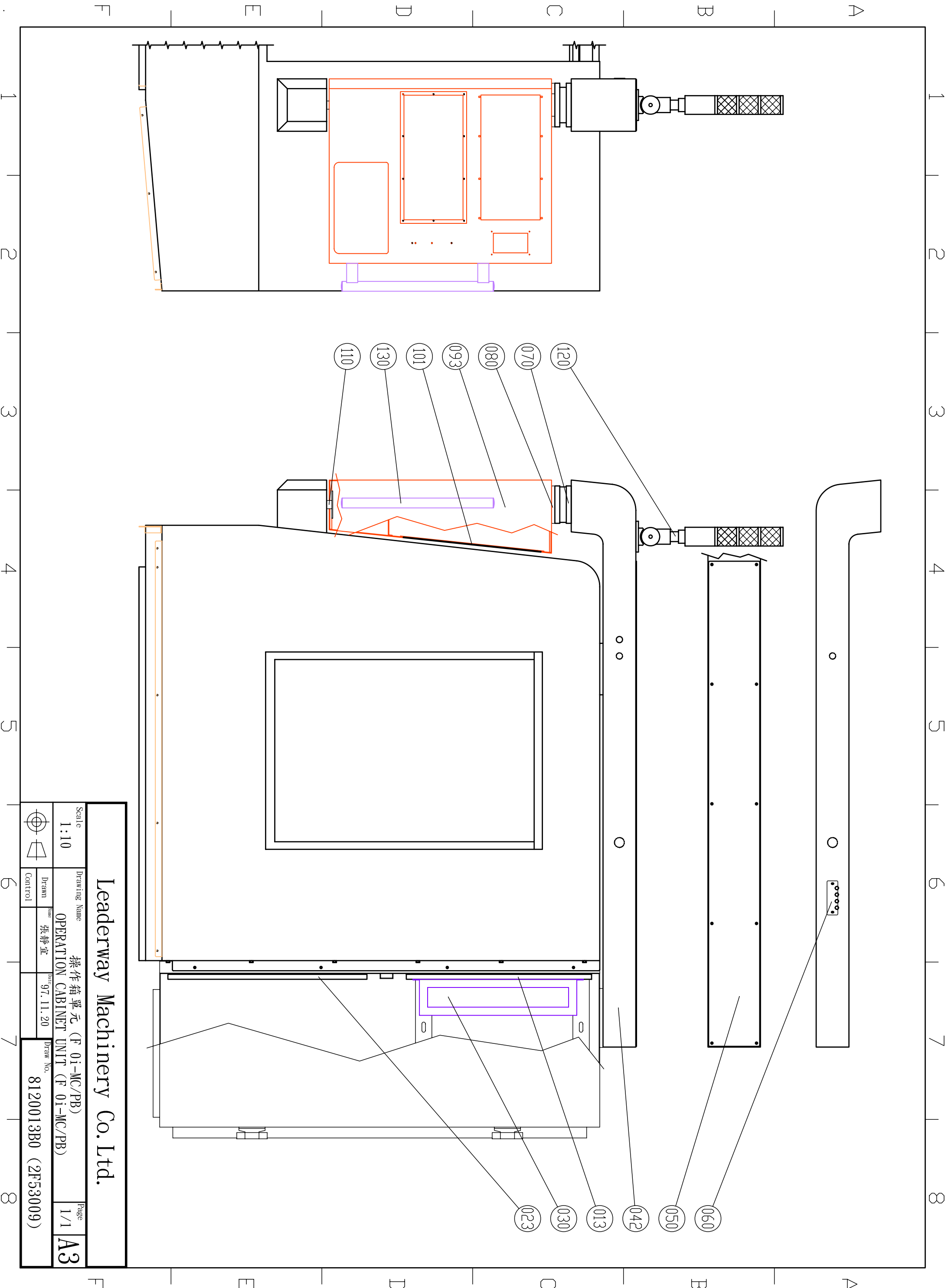

Leaderway Machinery Co. Ltd.

Scale		Drawing Name		Page	
1:10		操作箱單元 (F 0i-MC/PB) OPERATION CABINET UNIT (F 0i-MC/PB)		1/1	
Drawn		Date		Draw No.	
Control		張靜宜		97.11.20	
				8120013B0 (2F53009)	

A3

台灣力得衛宇龍科技股份有限公司

*單階材料用量清單

製表日期: 099-09-08

第1頁

主件品號	序號	元件品號	品名 英文品名	規 格	數量
2F53010			操作箱單元 S810D OPERATION CABINET UNIT	V33i/V42i	
	0015	3582022H0	I/O基板(上) I/O BOARD	7560\SPCCZ	1
	0023	3582023E0	I/O基板 I/O BOARD	7560\SPCCZ	1
	0033	3582032F0	線槽 CONDUIT	7530\SPCC	1
	0040	3582033A0	線槽蓋板 CONDUIT COVER	7540\SPCC	1
	0050	3582034A0	第四軸蓋板(槽) 4TH GUARD COVER	7540\SPCC	1
	0060	3500129A0	旋轉座 ROTATION BRACKET	3240\S45C	1
	0070	3581087C0	轉接板 CONNECTOR BOARD	3230\SS41	1
	0081	3582080B0	操作箱(S810D) OPERATION CABINET	7460\SPCC	1
	0091	3581081D0	操作箱後蓋板 CABINET REAR COVER	7460\SPCC	1
	0100	3582037A0	操作箱下固定座 SHIPPING BRACKET	7460\SPCC	1
	0111	4720632243	警示燈(三層) WARNING LIGHT	GSL-24V-3-B	1
	0120	4300400400	管型把手(自然色) HANDLE	U1-400L	1

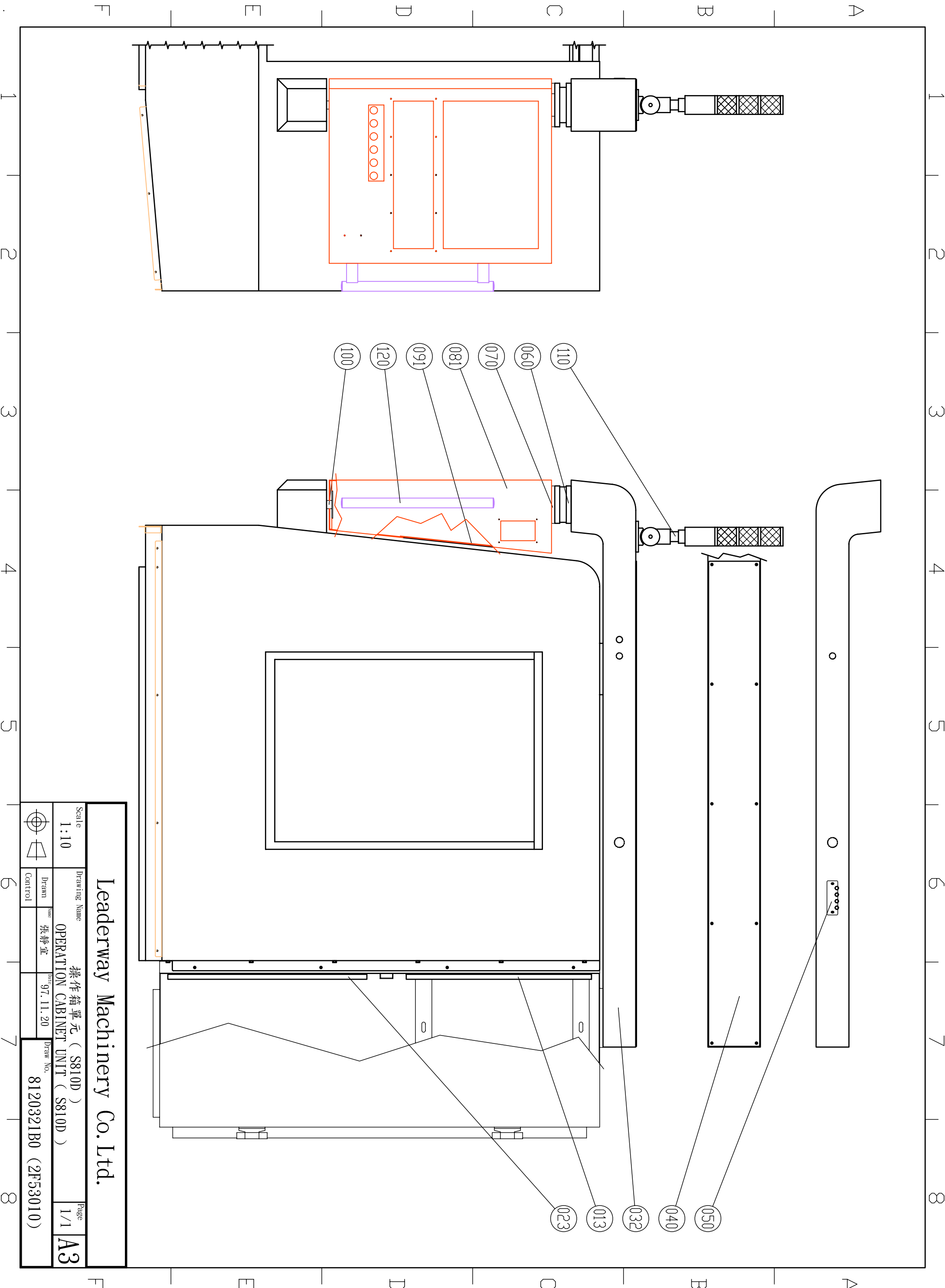

Leaderway Machinery Co. Ltd.

Scale 1:10		Drawing Name 操作箱單元 (S810D) OPERATION CABINET UNIT (S810D)		Page 1/1
Drawn Control	Name 張靜宜	Date 97.11.20	Draw No. 8120321B0 (2F53010)	A3

台灣力得衛宇龍科技股份有限公司

*單階材料用量清單

製表日期: 099-09-08

第1頁

主件品號	序號	元件品號	品名 英文品名	規 格	月量
2F53011			操作箱單元 F 0i-MC/PA OPERATION CABINET UNIT	V33i/V42i	
	0015	3582022H0	I/O基板(上) I/O BOARD	7560\SPCCZ	1
	0023	3582023E0	I/O基板 I/O BOARD	7560\SPCCZ	1
	0031	3581250A0	驅動器固定架 FIXED BRACKET, DRIVER	7560\SPCC	1
	0043	3582032F0	線槽 CONDUIT	7530\SPCC	1
	0050	3582033A0	線槽蓋板 CONDUIT COVER	7540\SPCC	1
	0060	3582034A0	第四軸蓋板(槽) 4TH GUARD COVER	7540\SPCC	1
	0070	3500129A0	旋轉座 ROTATION BRACKET	3240\S45C	1
	0080	3581087C0	轉接板 CONNECTOR BOARD	3230\SS41	1
	0093	3582036F0	操作箱(FANUC 0iMC) OPERATION CABINET	7460\SPCC	1
	0101	3581081D0	操作箱後蓋板 CABINET REAR COVER	7460\SPCC	1
	0110	3582037A0	操作箱下固定座 SHIPPING BRACKET	7460\SPCC	1
	0121	4720632243	警示燈(三層) WARNING LIGHT	GSL-24V-3-B	1
	0130	4300400400	管型把手(自然色) HAHDLE	U1-400L	1

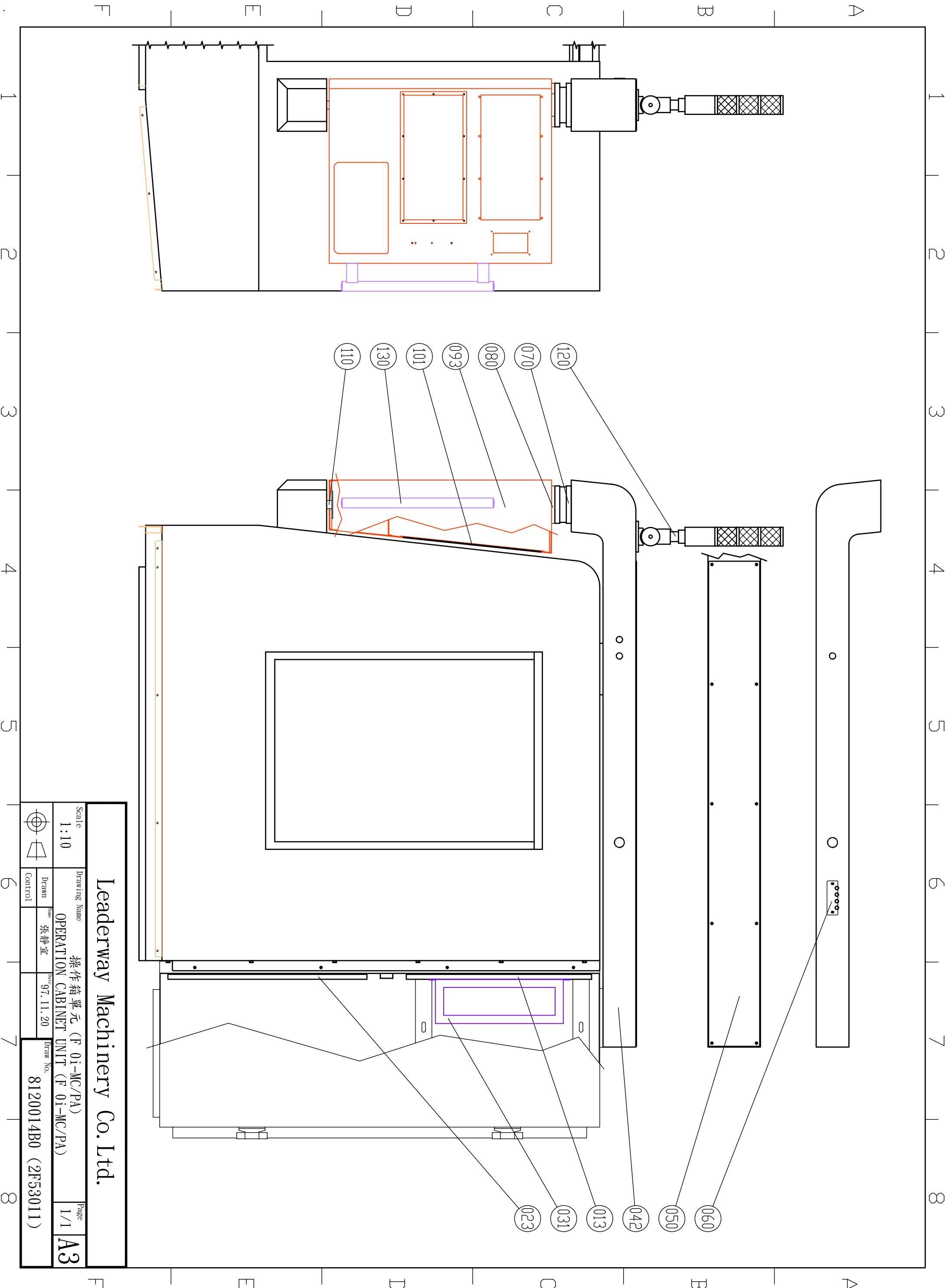

Leaderway Machinery Co. Ltd.

Scale		Drawing Name		Page	
1:10		操作箱單元 (F 0i-MC/PA) OPERATION CABINET UNIT (F 0i-MC/PA)		1/1	
Drawn		Date		Draw No.	
Control		張靜宜		8120014B0 (2F53011)	
		97.11.20			

台灣力得衛宇龍科技股份有限公司

*單階材料用量清單

製表日期: 099-09-08

第1頁

主件品號	序號	元件品號	品名 英文品名	規 格	月量
2F53020			操作箱單元 H.D.H iTNC530i OPERATION CABINET UNIT	V33i	
	0015	3582022H0	I/O基板(上) I/O BOARD	7560\SPCCZ	1
	0022	3582023E0	I/O基板 I/O BOARD	7560\SPCCZ	1
	0033	3582032F0	線槽 CONDUIT	7530\SPCC	1
	0040	3582033A0	線槽蓋板 CONDUIT COVER	7540\SPCC	1
	0050	3582034A0	第四軸蓋板(槽) 4TH GUARD COVER	7540\SPCC	1
	0060	3500129A0	旋轉座 ROTATION BRACKET	3240\S45C	1
	0070	3581087C0	轉接板 CONNECTOR BOARD	3230\SS41	1
	0082	3581254D0	操作箱(H.D.H 530i) OPERATION CABINET	7460\SPCC	1
	0091	3581316A0	操作箱後蓋 CABINET REAR COVER	7460\SPCC	1
	0100	3582037A0	操作箱下固定座 SHIPPING BRACKET	7460\SPCC	1
	0111	4720632243	警示燈(三層) WARNING LIGHT	GSL-24V-3-B	1
	0120	4300400400	管型把手(自然色) HAHDLE	U1-400L	1
	0130	3581152A0	摺動罩延伸蓋板 TELESCOPIC COVER REAR COVER	7210\SPCC	1

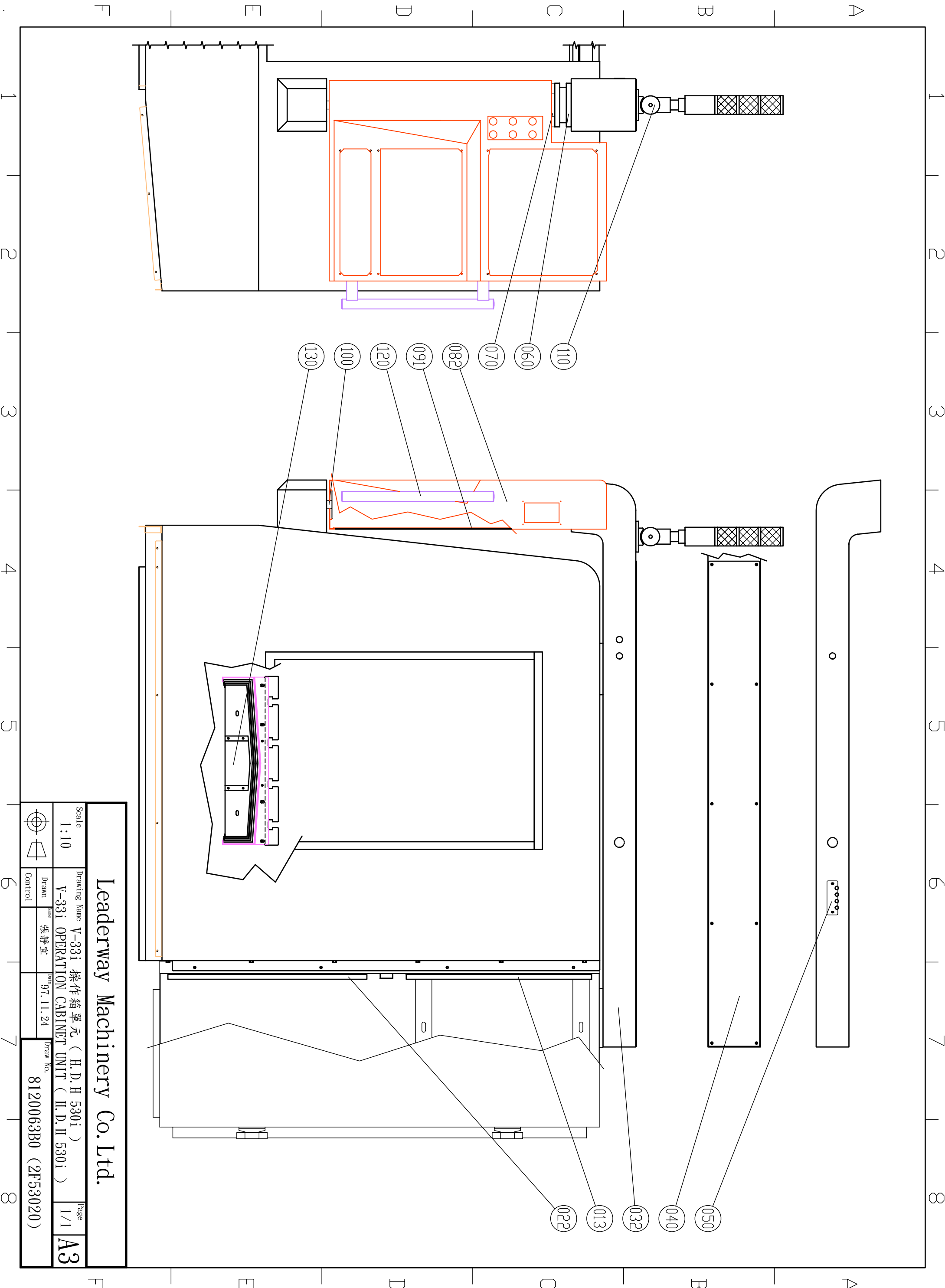

Leaderway Machinery Co. Ltd.

Scale 1:10		Drawing Name V-33i 操作箱單元 (H.D.H 530i)		Page 1/1
Drawn 張靜宜		V-33i OPERATION CABINET UNIT (H.D.H 530i)		A3
Control	Date 97.11.24	Draw No. 8120063B0 (2F53020)		

台灣力得衛宇龍科技股份有限公司

*單階材料用量清單

製表日期: 099-09-08

第1頁

主件品號	序號	元件品號	品名 英文品名	規 格	月量
2F53021			操作箱單元 F 18i OPERATION CABINET UNIT	V33i/V42i	
	0015	3582022H0	I/O基板(上) I/O BOARD	7560\SPCCZ	1
	0022	3582023E0	I/O基板 I/O BOARD	7560\SPCCZ	1
	0031	3581086B0	驅動器固定架(0iMC-PA/18i) FIXED BRACKET, DRIVER	7560\SPCCZ	1
	0043	3582032F0	線槽 CONDUIT	7530\SPCC	1
	0050	3582033A0	線槽蓋板 CONDUIT COVER	7540\SPCC	1
	0060	3582034A0	第四軸蓋板(槽) 4TH GUARD COVER	7540\SPCC	1
	0070	3500129A0	旋轉座 ROTATION BRACKET	3240\S45C	1
	0080	3581087C0	轉接板 CONNECTOR BOARD	3230\SS41	1
	0091	3581255B0	操作箱(FANUC 18i) OPERATION CABINET	7460\SPCC	1
	0100	3581081D0	操作箱後蓋板 CABINET REAR COVER	7460\SPCC	1
	0110	3582037A0	操作箱下固定座 SHIPPING BRACKET	7460\SPCC	1
	0121	4720632243	警示燈(三層) WARNING LIGHT	GSL-24V-3-B	1

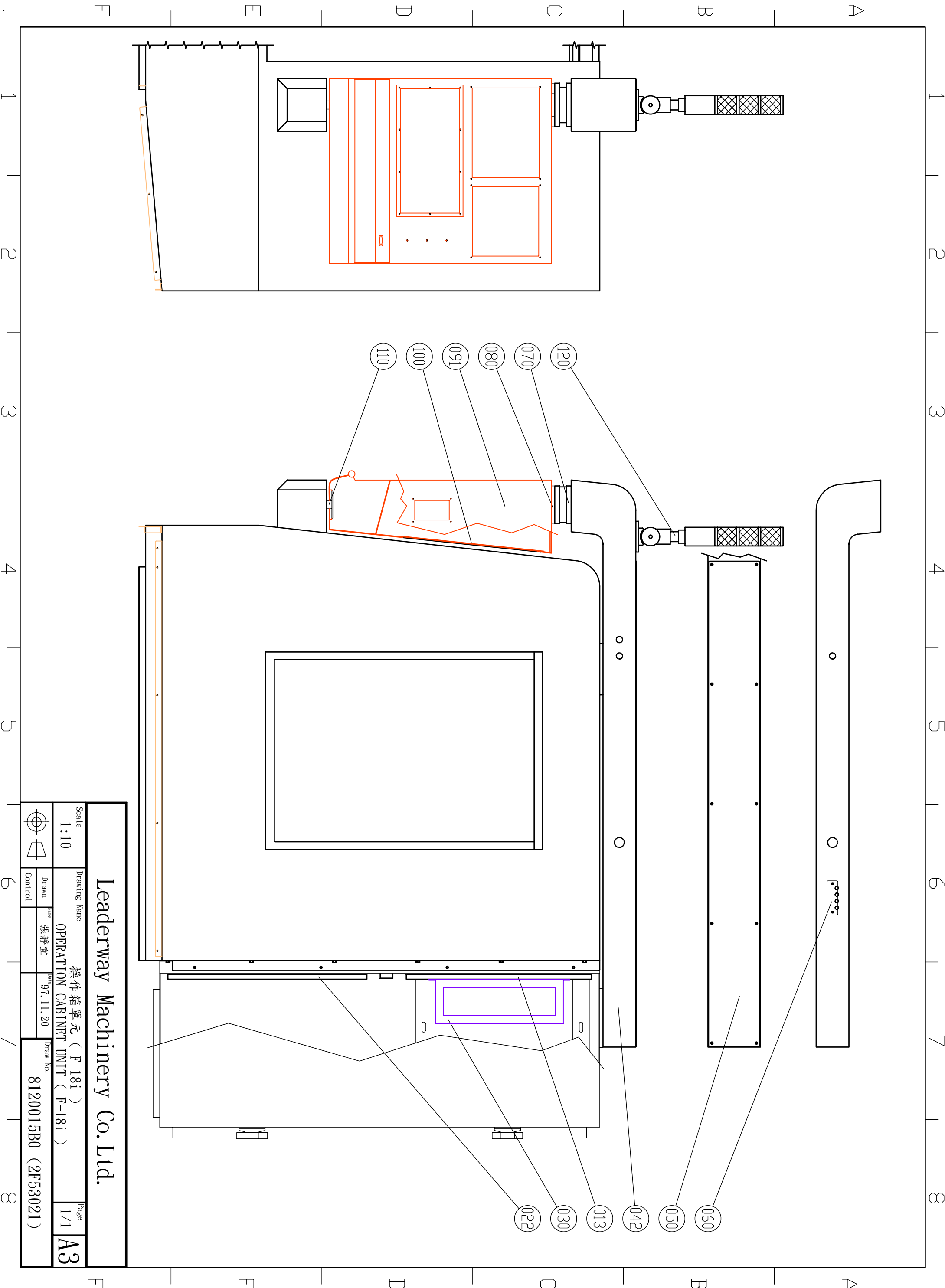

Leaderway Machinery Co. Ltd.

Scale		Drawing Name		Page	
1:10		操作箱單元 (F-18i) OPERATION CABINET UNIT (F-18i)		1/1	
Drawn		Date		Draw No.	
Control		張靜宜		8120015B0 (2F53021)	
		97.11.20			

台灣力得衛宇龍科技股份有限公司

*單階材料用量清單

製表日期: 099-09-08

第1頁

主件品號	序號	元件品號	品名 英文品名	規 格	月量
2F53025			操作箱單元 S802D-SL OPERATION CABINET UNIT	V33i/V42i	
	0015	3582022H0	I/O基板(上) I/O BOARD	7560\SPCCZ	1
	0021	3582023E0	I/O基板 I/O BOARD	7560\SPCCZ	1
	0033	3582032F0	線槽 CONDUIT	7530\SPCC	1
	0040	3582033A0	線槽蓋板 CONDUIT COVER	7540\SPCC	1
	0050	3582034A0	第四軸蓋板(槽) 4TH GUARD COVER	7540\SPCC	1
	0060	3500129A0	旋轉座 ROTATION BRACKET	3240\S45C	1
	0070	3581087C0	轉接板 CONNECTOR BOARD	3230\SS41	1
	0082	3581283C0	操作箱(S802D-SL) OPERATION CABINET	7460\SPCC	1
	0090	3581081D0	操作箱後蓋板 CABINET REAR COVER	7460\SPCC	1
	0100	3582037A0	操作箱下固定座 SHIPPING BRACKET	7460\SPCC	1
	0111	4720632243	警示燈(三層) WARNING LIGHT	GSL-24V-3-B	1
	0120	4300400400	管型把手(自然色) HAHDLE	U1-400L	1
	0130	3995004A0	操作面板 OPERATION PANLE	4340/S802D-SL專用	1

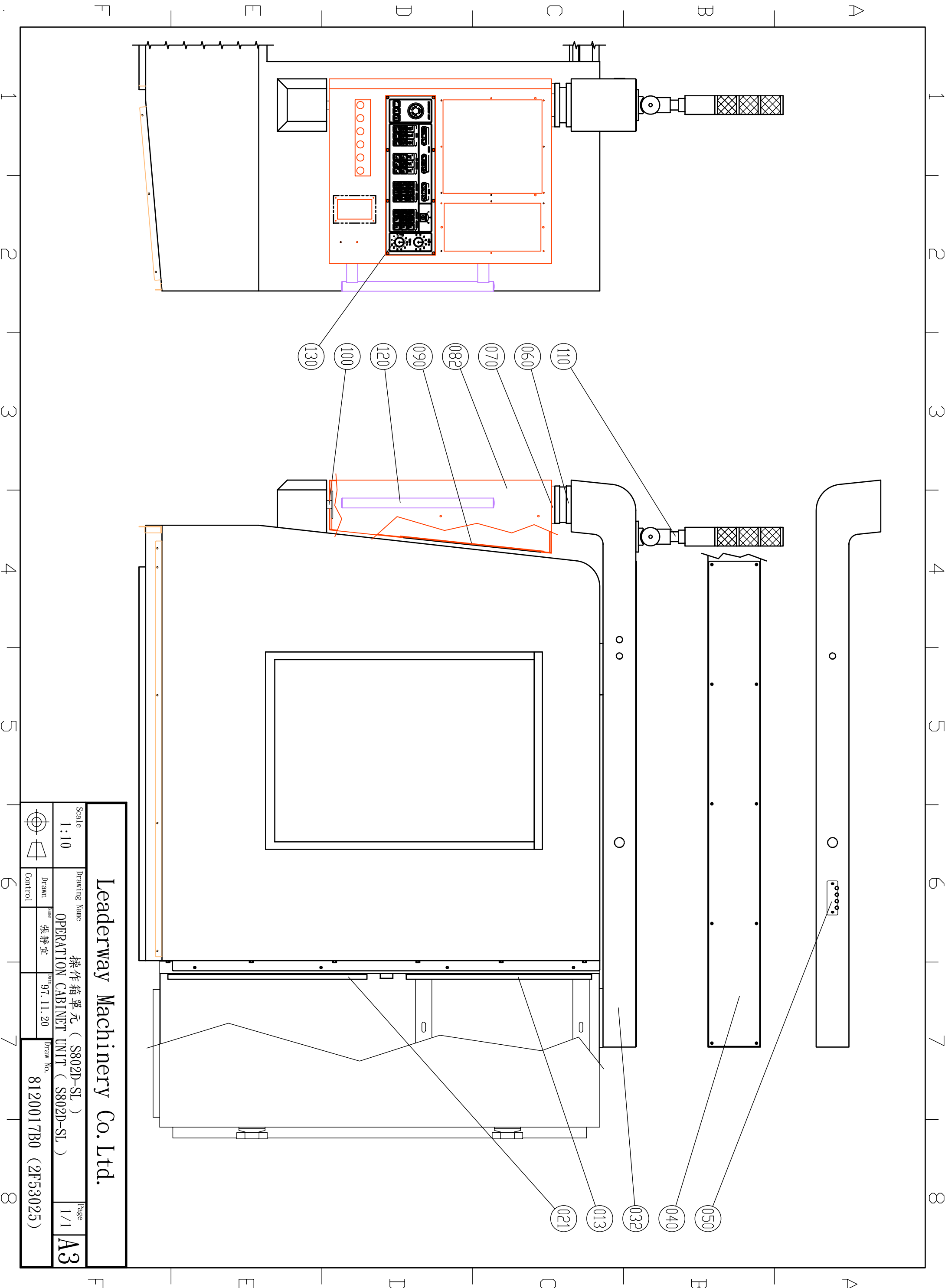

Leaderway Machinery Co. Ltd.

Scale 1:10		Drawing Name 操作箱單元 (S802D-SL) OPERATION CABINET UNIT (S802D-SL)		Page 1/1	
Drawn 張靜宜		Date 97.11.20		Draw No. 8120017B0 (2F53025)	
Control					

台灣力得衛宇龍科技股份有限公司

*單階材料用量清單

製表日期: 099-09-08

第1頁

主件品號	序號	元件品號	品名 英文品名	規 格	月量
2F53032			操作箱單元 三菱-70M OPERATION CABINET UNIT	V33i/V42i	
	0015	3582022H0	I/O基板(上) I/O BOARD	7560\SPCCZ	1
	0021	3582023E0	I/O基板 I/O BOARD	7560\SPCCZ	1
	0033	3582032F0	線槽 CONDUIT	7530\SPCC	1
	0040	3582033A0	線槽蓋板 CONDUIT COVER	7540\SPCC	1
	0050	3582034A0	第四軸蓋板(槽) 4TH GUARD COVER	7540\SPCC	1
	0060	3500129A0	旋轉座 ROTATION BRACKET	3240\S45C	1
	0070	3581087C0	轉接板 CONNECTOR BOARD	3230\SS41	1
	0081	3580262B0	操作箱 OPERATION CABINET	7460\SPCC	1
	0090	3581081D0	操作箱後蓋板 CABINET REAR COVER	7460\SPCC	1
	0100	3582037A0	操作箱下固定座 SHIPPING BRACKET	7460\SPCC	1
	0111	4720632243	警示燈(三層) WARNING LIGHT	GSL-24V-3-B	1
	0120	4300400400	管型把手(自然色) HAHDLE	U1-400L	1
	0132	3581309C0	洩放電阻座(大) BLEEDER RESISTANCE BRACKET	7210\SPCC	1
	0144	3581310E0	洩放電阻座蓋 COVER,BLEEDER RESISTANCE BRA	7210\SPCC	1

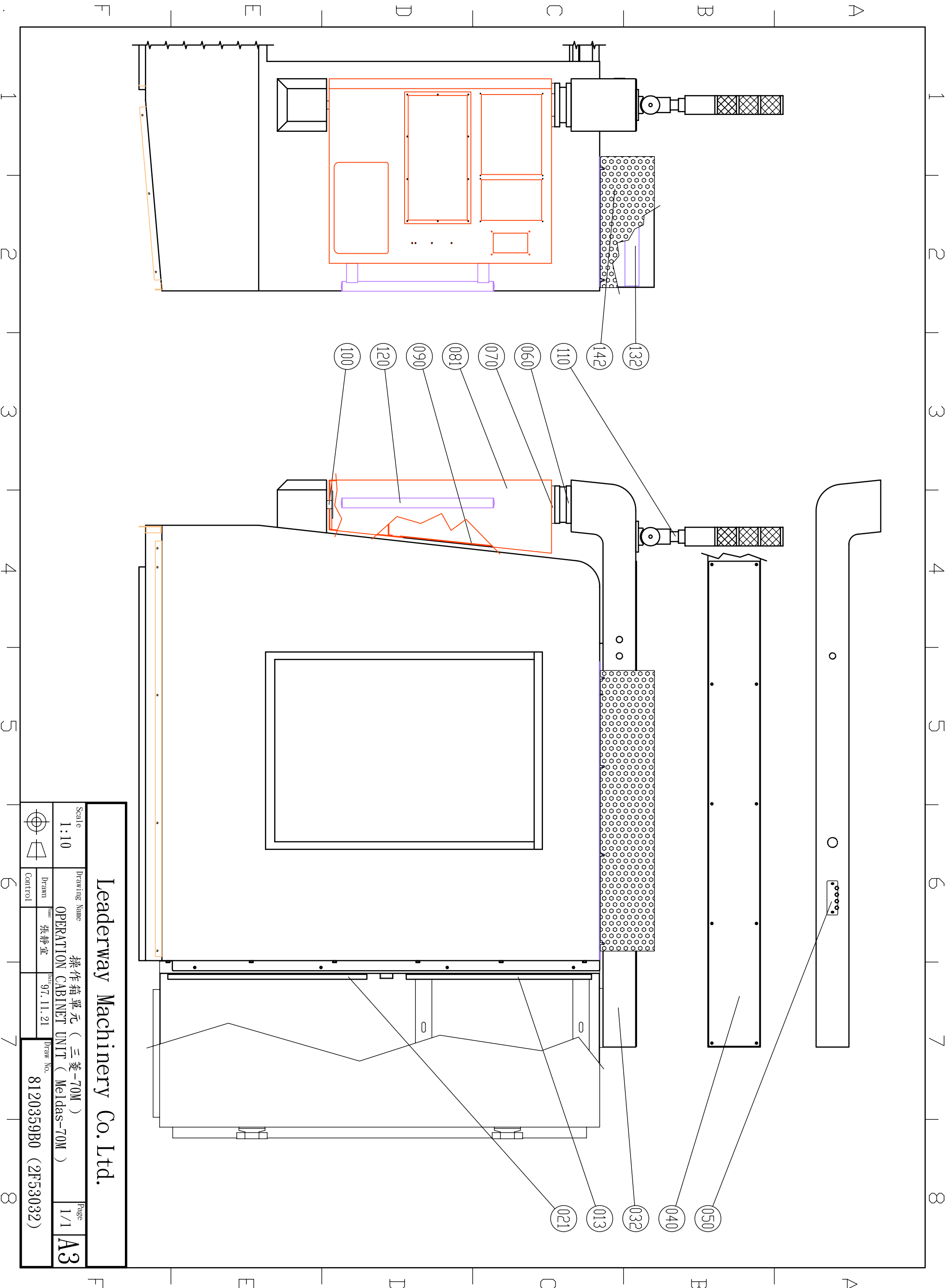

Leaderway Machinery Co. Ltd.

Scale 1:10		Drawing Name 操作箱單元 (三菱-70M) OPERATION CABINET UNIT (Meldas-70M)		Page 1/1
Drawn Control	Drawn 張靜宜	Date 97.11.21	Draw No. 8120359B0 (2F53032)	A3

台灣力得衛宇龍科技股份有限公司

*單階材料用量清單

製表日期: 099-09-08

第1頁

主件品號	序號	元件品號	品名 英文品名	規 格	月量
2F53037			操作箱單元 FAGOR 8055i OPERATION CABINET UNIT	V33i/V42i	
	0014	3582022H0	I/O基板(上) I/O BOARD	7560\SPCCZ	1
	0020	3582023E0	I/O基板 I/O BOARD	7560\SPCCZ	1
	0033	3582032F0	線槽 CONDUIT	7530\SPCC	1
	0040	3582033A0	線槽蓋板 CONDUIT COVER	7540\SPCC	1
	0050	3582034A0	第四軸蓋板(槽) 4TH GUARD COVER	7540\SPCC	1
	0060	3500129A0	旋轉座 ROTATION BRACKET	3240\S45C	1
	0070	3581087C0	轉接板 CONNECTOR BOARD	3230\SS41	1
	0081	3581311B0	操作箱(FAGOR 8055i) OPERATION CABINET	7460\SPCC	1
	0090	3581081D0	操作箱後蓋板 CABINET REAR COVER	7460\SPCC	1
	0100	3582037A0	操作箱下固定座 SHIPPING BRACKET	7460\SPCC	1
	0111	4720632243	警示燈(三層) WARNING LIGHT	GSL-24V-3-B	1
	0120	4300400400	管型把手(自然色) HAHDLE	U1-400L	1
	0130	3995008A0	操作面板(FAGOR配用機械面板) OPERATION PANLE	9340	1

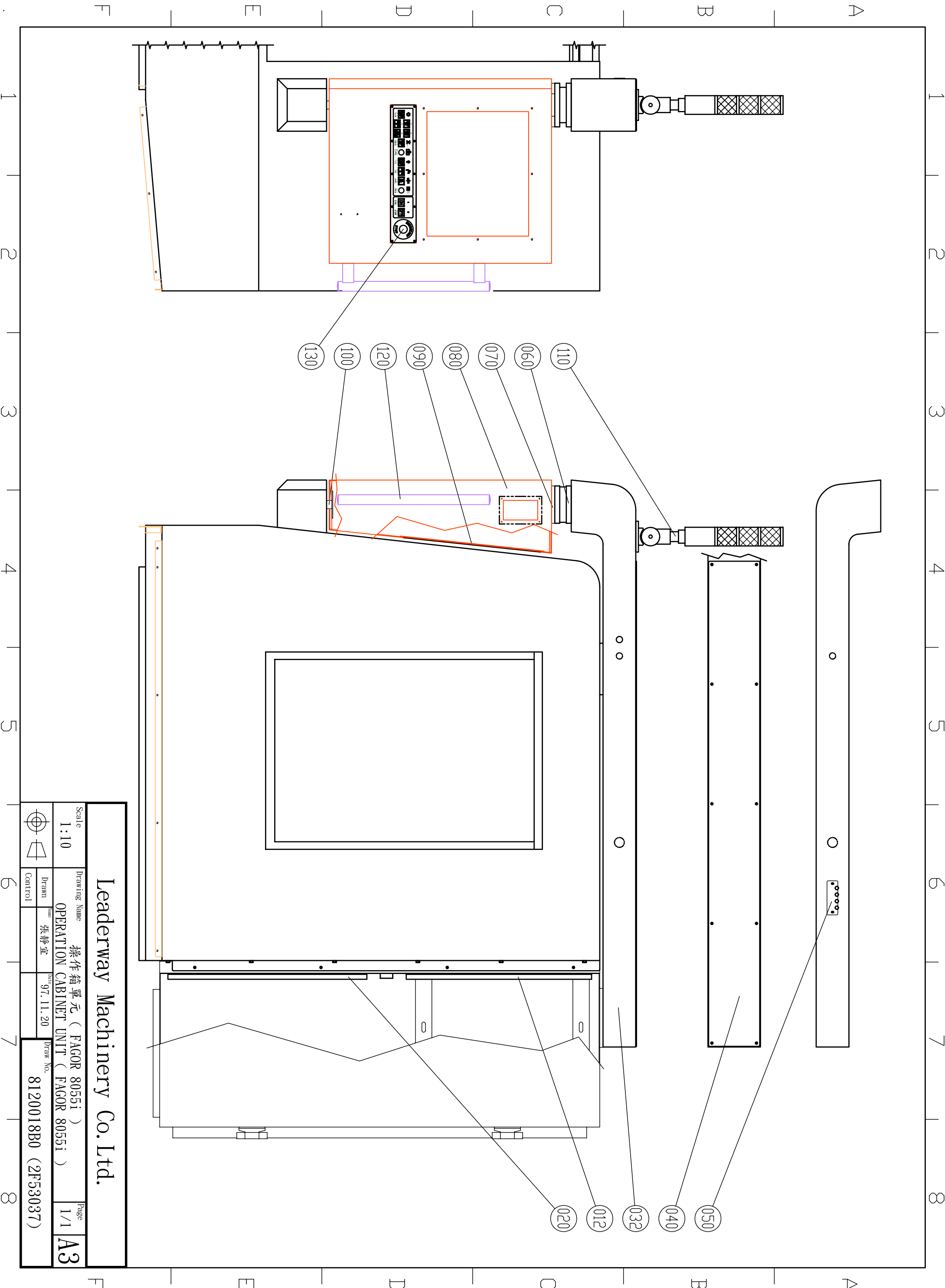

Leaderway Machinery Co. Ltd.

Scale 1:10		Drawing Name 操作箱單元 (FAGOR 8055i) OPERATION CABINET UNIT (FAGOR 8055i)		Page 1/1
Drawn Control	Name 張靜宜	Date 97.11.20	Draw No. 8120018B0 (2F53037)	A3

台灣力得衛宇龍科技股份有限公司

*單階材料用量清單

製表日期: 099-09-08

第1頁

主件品號	序號	元件品號	品名 英文品名	規 格	月量
2F28041			主軸皮帶輪單元\V33i\V42i SPINDLE BELT UNIT	Meldas SJ-V15-01ZT(F)	
	0011	3582146B0	主軸馬達增高墊 MOTOR PAD	3210\SS41	1
	0021	3582147B0	主軸馬達板 ADJUSTABLE PLATE	3170\SS41	1
	0030	3971060A0	齒型皮帶輪(5GT-75T) PULLEY	3270\S45C	1
	0040	3500020B0	馬達軸端蓋 SHAFT END COVER	3170\S45C	1
	0050	4601035850	齒型皮帶(剖溝)	5GT*35*850	1

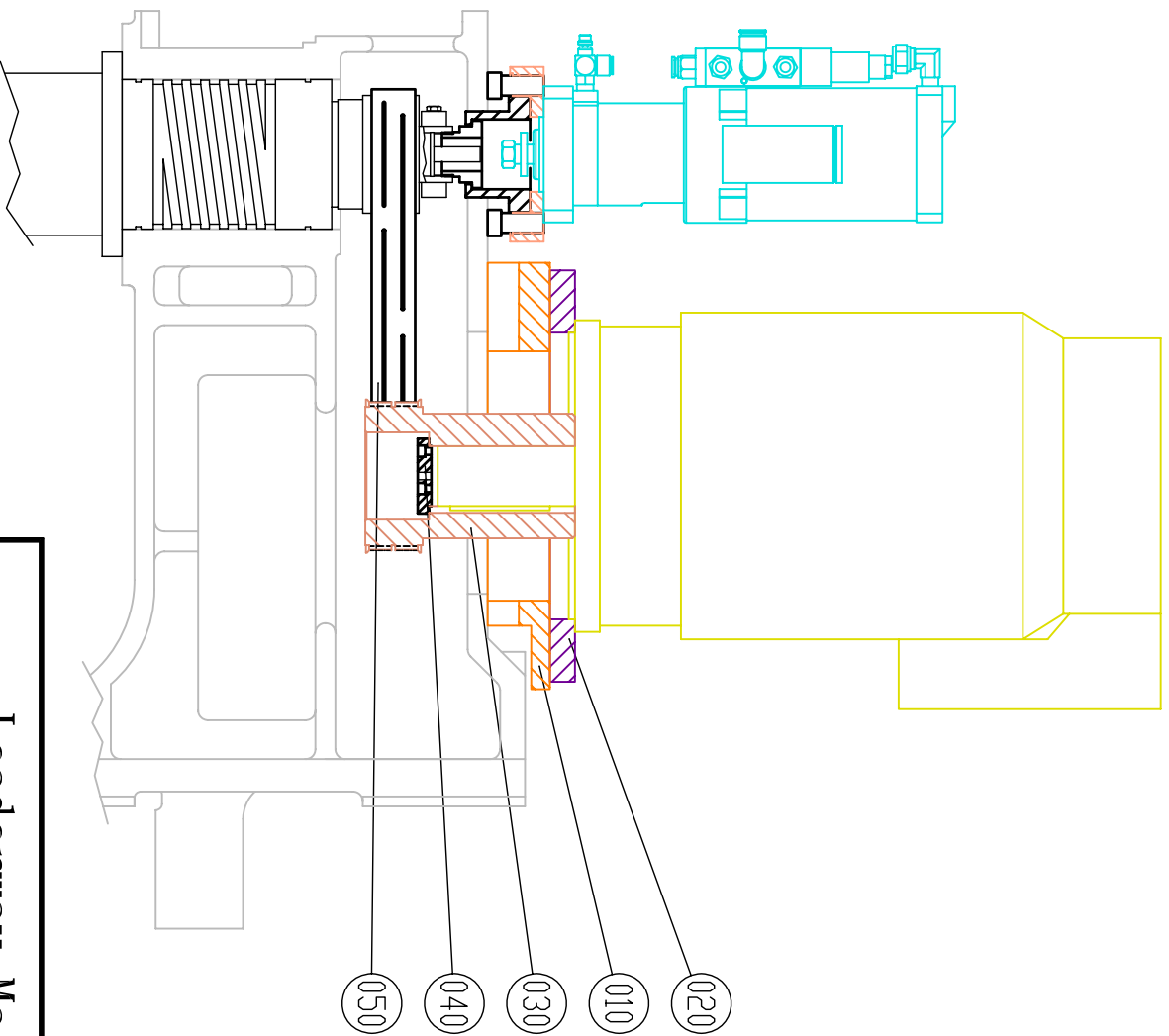

Leaderway Machinery Co. Ltd.

Scale 1:6		Drawing Name 主軸皮帶輪單元 (Meldas SJ-V15) SPINDLE BELT UNIT (Meldas SJ-V15)		Page 1/1
Drawn 張靜宜	DATE 99.01.27	Draw No. 8120450A0 (2F28041)	A4	
Control				

台灣力得衛宇龍科技股份有限公司

*單階材料用量清單

製表日期: 099-09-08

第1頁

主件品號	序號	元件品號	品名 英文品名	規 格	用量
2F11039			主軸頭+立柱單元(主馬加大) SPINDLE HEAD + COLUMN UNIT	V33i\W42i	
	0010	3500012B0	滑座壓塊 SLIDING BLOCK,ADJUSTABLE BRA	3210\SS41	4
	0020	3500014B0	碰塊座 DOG BRACKET	4140\AL(250m/m*3軌)	1
	0030	3500081A0	碰塊 DOG	3140\SS41(42m/m)	2
	0040	3500306A0	管接頭座 CONNECTOR BRACKET	3150\S45C	1
	0050	3540007A0	碰塊 DOG	4140\AL 外購65L	1
	0060	3580047B0	微動開關座(Z軸) MICRO SWITCH BRACKET, Z AXIS	7160\SPCC	1
	0070	3580048A0	碰塊座 DOG BRACKET	4140\AL(200m/m*2軌)	1
	0080	3580116D0	立柱 COLUMN	1020\FC-25\3580001B2	1
	0090	3581001C0	碰塊座蓋板 DOG BRACKET COVER	7210\SPCC	1
	0100	3581002B0	碰塊座固定板 FIXED PLATE, DOG BRACKET	7210\SPCC	1
	0110	3581003A0	主軸頭左後側蓋板 (L)REAR COVER, SPINDLE HEAD	7510\SPCC	1
	0120	3582148A0	主軸頭左側蓋板 LEFT COVER, SPINDLE HEAD	7510\SPCC	1
	0130	3582149A0	主軸頭右側蓋板 RIGHT COVER, SPINDLE HEAD	7510\SPCC	1
	0140	3582150A0	主軸頭前蓋板 FRONT COVER BRACKET, SPINDLE	7510\SPCC	1
	0150	3581007A0	封蓋 HOLE COVER	7180\SPCC	1
	0160	3582151A0	連動管前支架 FRONT BRACKET, CONDUIT	7210\SPCC	1
	0170	3581010C0	噴水管座 NOZZLE TUBE BRACKET	3150\SS41	1
	0180	3581011A0	孔蓋 HOLE CAP	3230\S45C	2
	0190	3581012F0	主軸頭 SPINDLE HEAD	1010\FC-25\3581000D2	1
	0200	3581020E0	Z軸下摺動罩 LOWER TELESCOPIC COVER, Z	7400\SPCCZ	1
	0210	3985014B0	線性滑軌(滾柱型) LINEAR GUIDE(CYLINDRIC ROLLE	9840	1
	0220	4080106015	直銷(軸承鋼針) PIN	φ 6x15L	50
	0230	4640065133	方型聯動管 WIRE CONDUIT	KY-CE(CBS65.2)-65x133-(22目)	1
	0240	4800143204	微動開關 MICRO SWITCH	BNS819-B02-D12-61-12-10BALLU	1
	0250	4250101414	球閥內外牙 BALL VALVE	1/4"	2
	0260	3990144A0	刀具釋放指示牌 NAME PLATE	4350\AL	1
	0270	3500063B0	近接開關座 PROXIMITY SWITCH BRACKET	7160\SPCC	1
	0280	4210114016	噴水管 NOZZLE TUBE	1/4"轉接頭*軟管x16*1/4"噴嘴	2
	0290	3581248B0	立柱右飾板 COLUMN PLATE	7510\SPCC	1
	0300	3581249B0	立柱左飾板 COLUMN PLATE	7510\SPCC	1

<續下頁>

台灣力得衛宇龍科技股份有限公司

*單階材料用量清單

製表日期: 099-09-08

第2頁

主件品號	序號	元件品號	品名 英文品名	規 格	月量
2F11039	0310	3580279A0	機頭側壓克力 ACRYLIC PLATE, SPINDLE HEAD	4360\ACRY	1

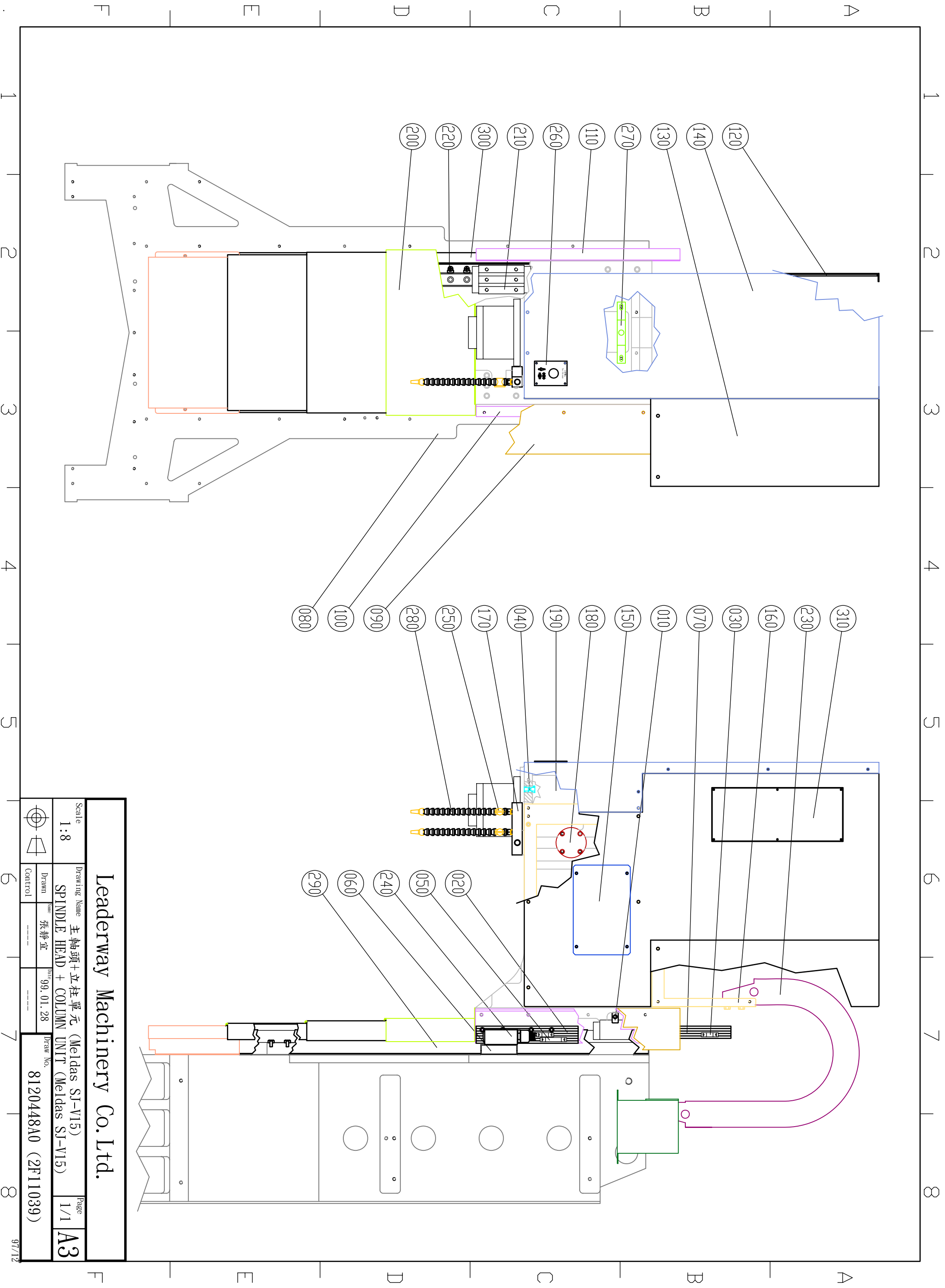

Leaderway Machinery Co. Ltd.

Scale 1:8	Drawing Name 主軸頭+立柱單元 (Meldas SJ-V15) SPINDLE HEAD + COLUMN UNIT (Meldas SJ-V15)		Page 1/1
	Drawn 張靜宜	Date 99.01.28	Draw No. 8120448A0 (2F11039)
	Control		

台灣力得衛宇龍科技股份有限公司

*單階材料用量清單

製表日期: 099-09-08

第1頁

主件品號	序號	元件品號	品名 英文品名	規 格	月量
2F53048			操作箱單元 三菱-70M OPERATION CABINET UNIT	V33i/V42i(主馬加大)	
	0011	3582022H0	I/O基板(上) I/O BOARD	7560\SPCCZ	1
	0020	3582023E0	I/O基板 I/O BOARD	7560\SPCCZ	1
	0030	3582032F0	線槽 CONDUIT	7530\SPCC	1
	0040	3582033A0	線槽蓋板 CONDUIT COVER	7540\SPCC	1
	0050	3582034A0	第四軸蓋板(槽) 4TH GUARD COVER	7540\SPCC	1
	0060	3500129A0	旋轉座 ROTATION BRACKET	3240\S45C	1
	0070	3581087C0	轉接板 CONNECTOR BOARD	3230\SS41	1
	0080	3582145A0	操作箱 OPERATION CABINET	7460\SPCC	1
	0090	3581081D0	操作箱後蓋板 CABINET REAR COVER	7460\SPCC	1
	0100	3582037A0	操作箱下固定座 SHIPPING BRACKET	7460\SPCC	1
	0110	4720632243	警示燈(三層) WARNING LIGHT	GSL-24V-3-B	1
	0120	4300400400	管型把手(自然色) HAHDLE	U1-400L	1
	0130	3582152A0	洩放電阻座 BLEEDER RESISTANCE BRACKET	7210\SPCC	1
	0142	3582153C0	洩放電阻座蓋 COVER,BLEEDER RESISTANCE BRA	7210\SPCC	1
	0151	3582144B0	驅動器固定架 FIXED BRACKET, DRIVER	7560\SPCC	1

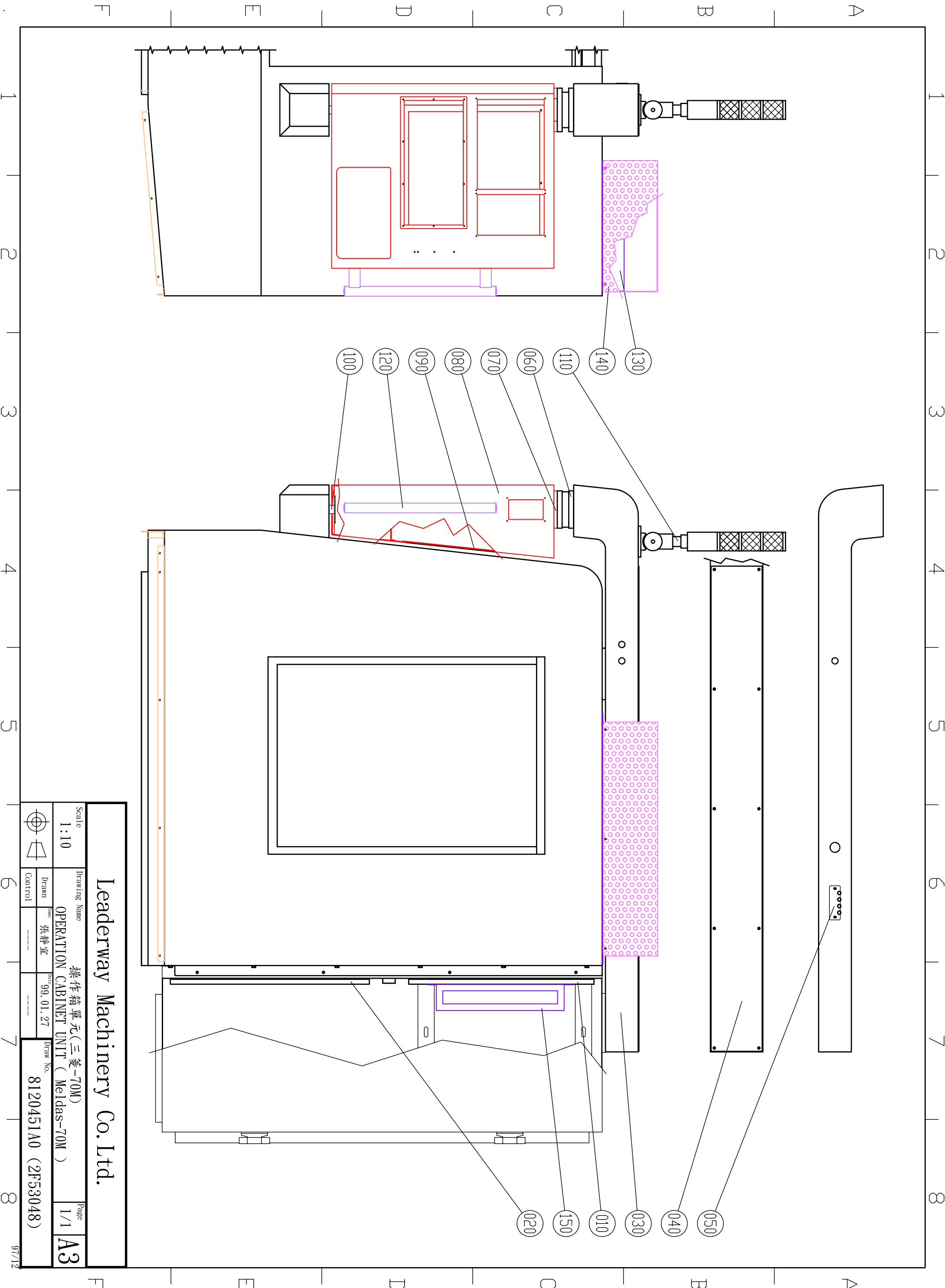

Leaderway Machinery Co. Ltd.

Scale 1:10		Drawing Name 操作箱單元(三菱-70M) OPERATION CABINET UNIT (Meldas-70M)		Page 1/1	
Drawn 張靜宜		Date 99.01.27		Draw No. 8120451A0 (2F53048)	
Control				A3	