



Leaderway VERTICAL MACHINING CENTER
(LINEAR GUIDE WAY)

VERTICAL MACHINING CENTER

PARTS LIST

V42iW

LEADERWAY CNC TECHNOLOGIES CO., LTD.

NO. 36, Ln. 211, Taiming Rd.,
Wuri Dist, TAICHUNG 41468, TAIWAN

TEL: +886-4-2335-0711

FAX: +886-4-2335-0986



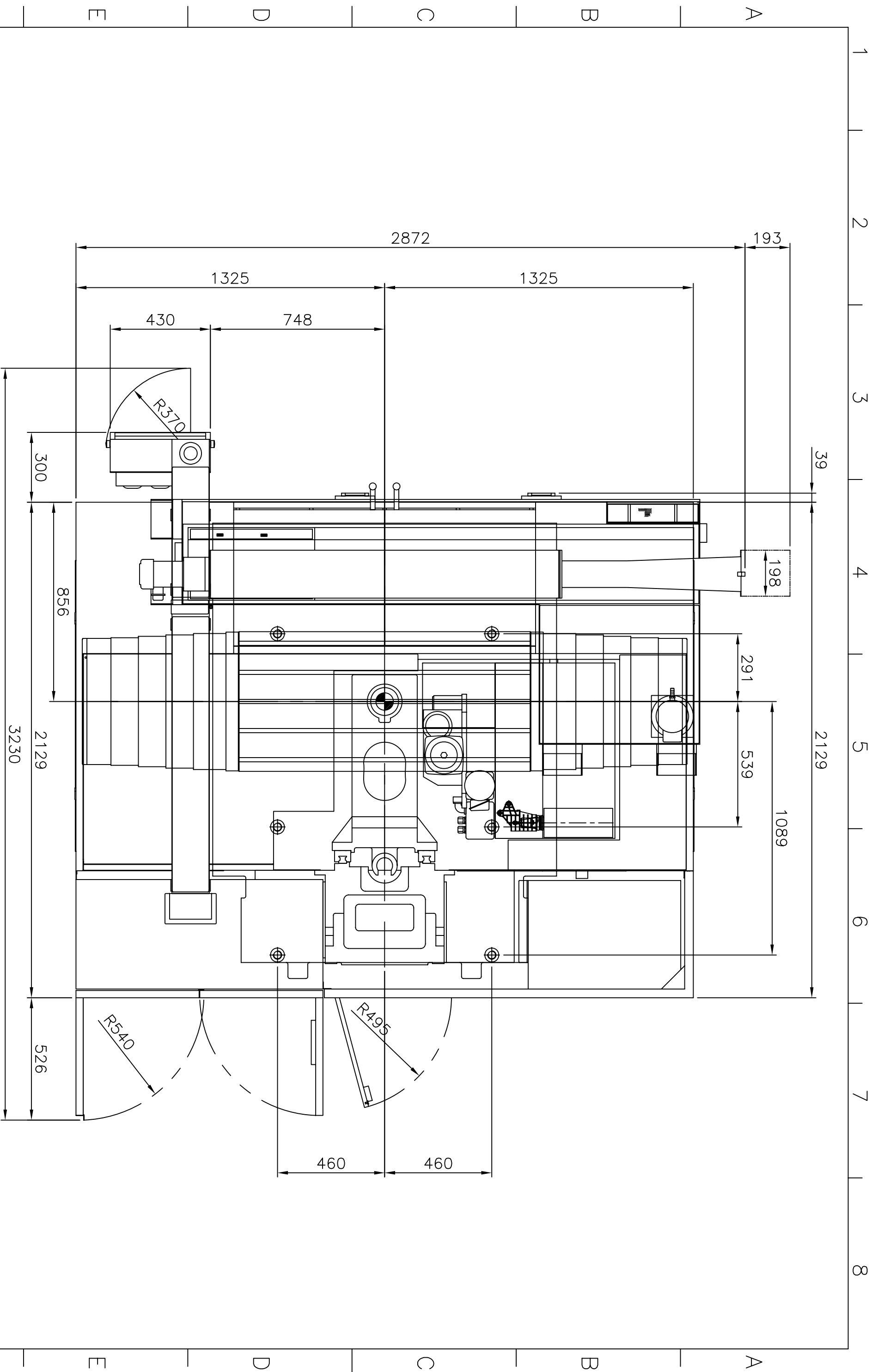

Leaderway Machinery Co. Ltd.

Scale	Drawing Name			Page
1:15	OUTLINE DIMENSION (TOP VIEW) 外型尺寸圖			1/4
Drawn	Name	Date	Draw No.	A3
Control	卜規云	101.03.09	8150248A0 (Y42: W)	

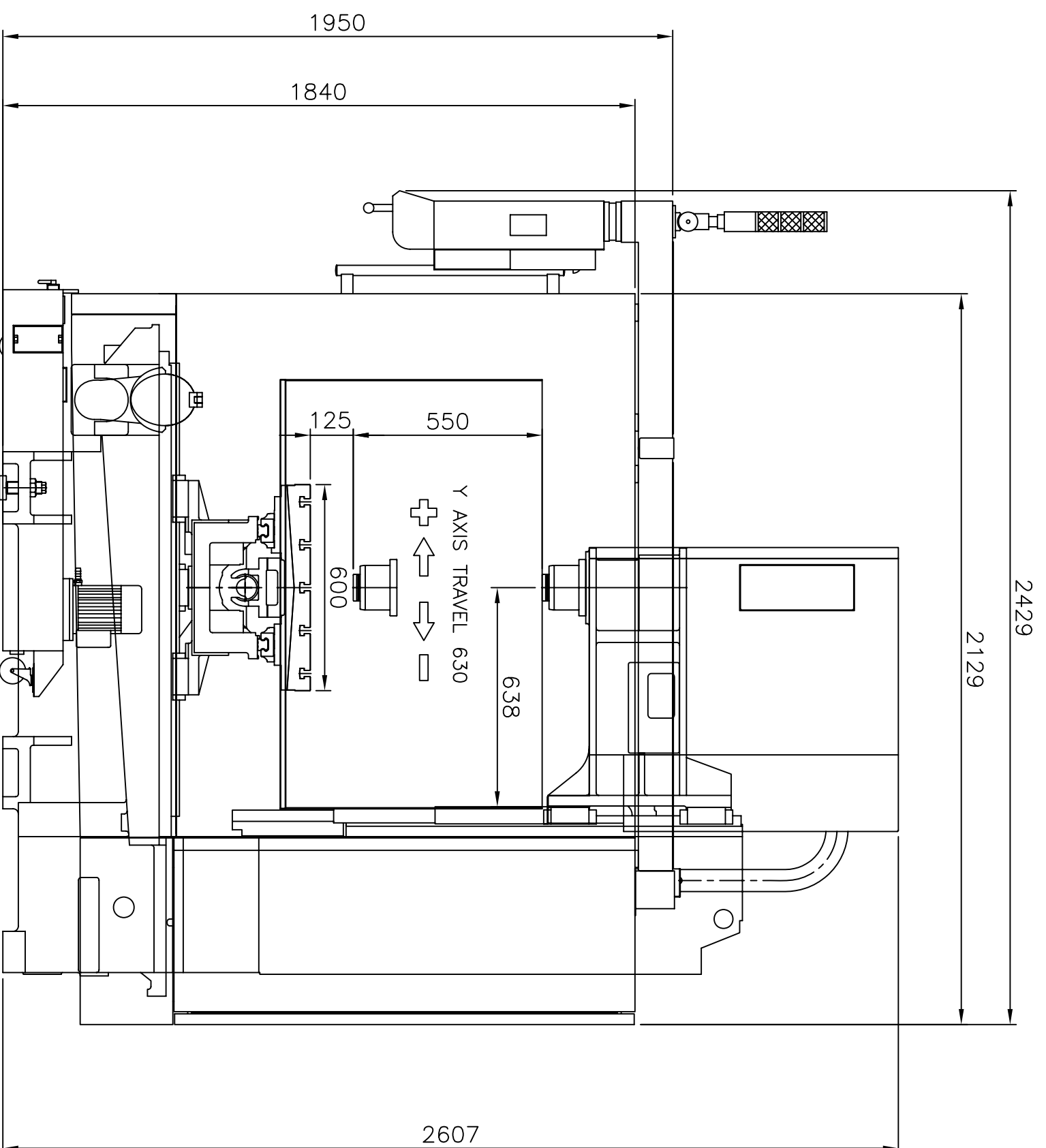

Leaderway Machinery Co. Ltd.

Scale	1:15		Drawing Name	OUTLINE DIMENSION (RIGHT SIDE VIEW) 外型尺寸圖		Page	2/4
Drawn	Control	Name	卜珮云	Date	101.03.09	Draw No.	8150248A0 (V421 W)

A3

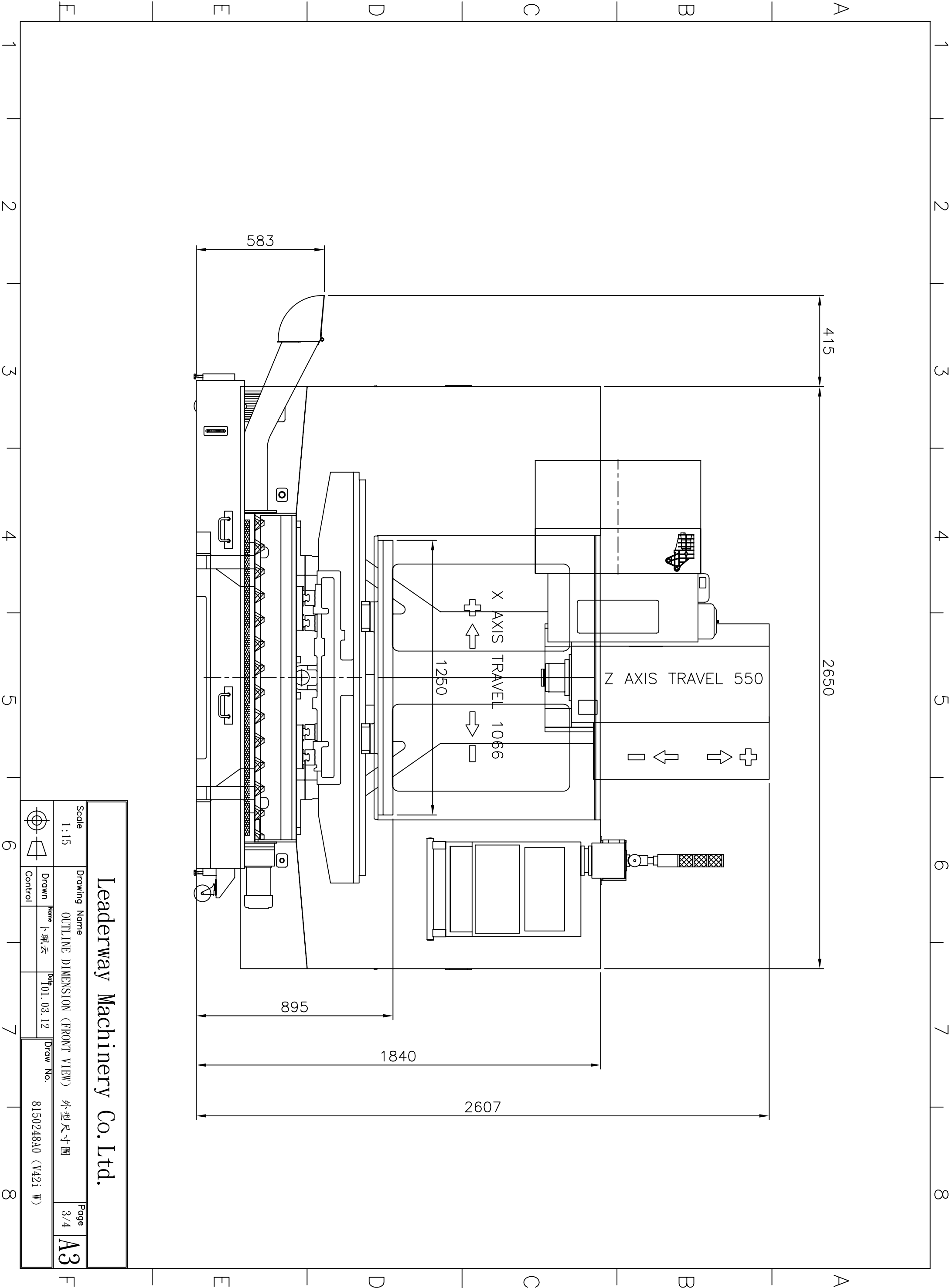

Leaderway Machinery Co. Ltd.

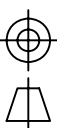
Scale	Drawing Name			Page
1:15	OUTLINE DIMENSION (FRONT VIEW)			3/4
	Drawn	Name	Date	Draw No.
	Control	卜根云	101.03.12	

A3

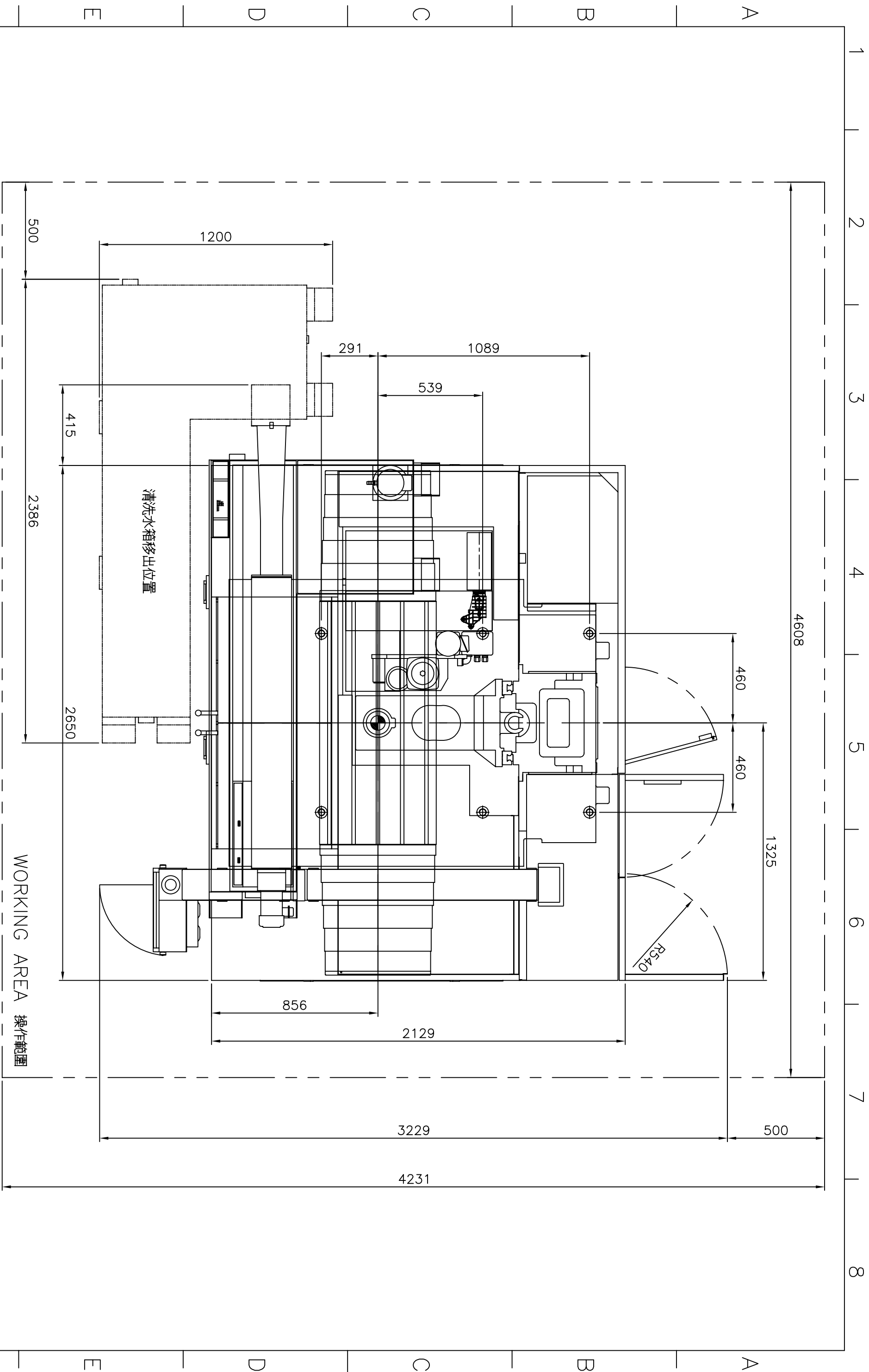

Leaderway Machinery Co. Ltd.

Scale 1:18	Drawing Name FOUNDATION ANCHOR SET UP DRAWING (地基圖)	Page 4/4
Drawn Control	Name 卜佩云	Draw No. 8150248A0 (V42i W +標準水箱)
	Date 101.03.12	

A3

A=350(V450/V650(V650HSM)/V331/V421)
 A=500(V1100/MV1100S/MV1100D/MV1300D/LX8/LX10
 A=700(LX1600/LX2200)
 A=1000(LX-B.....)

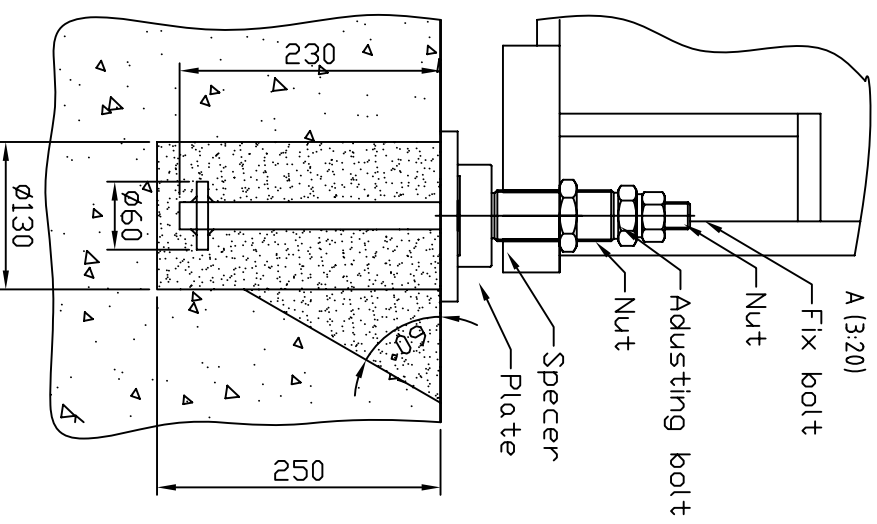
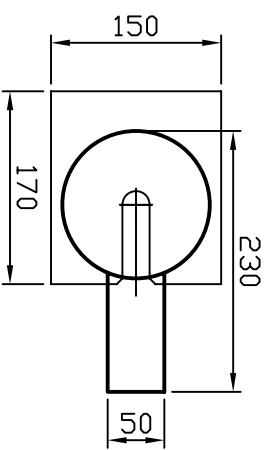
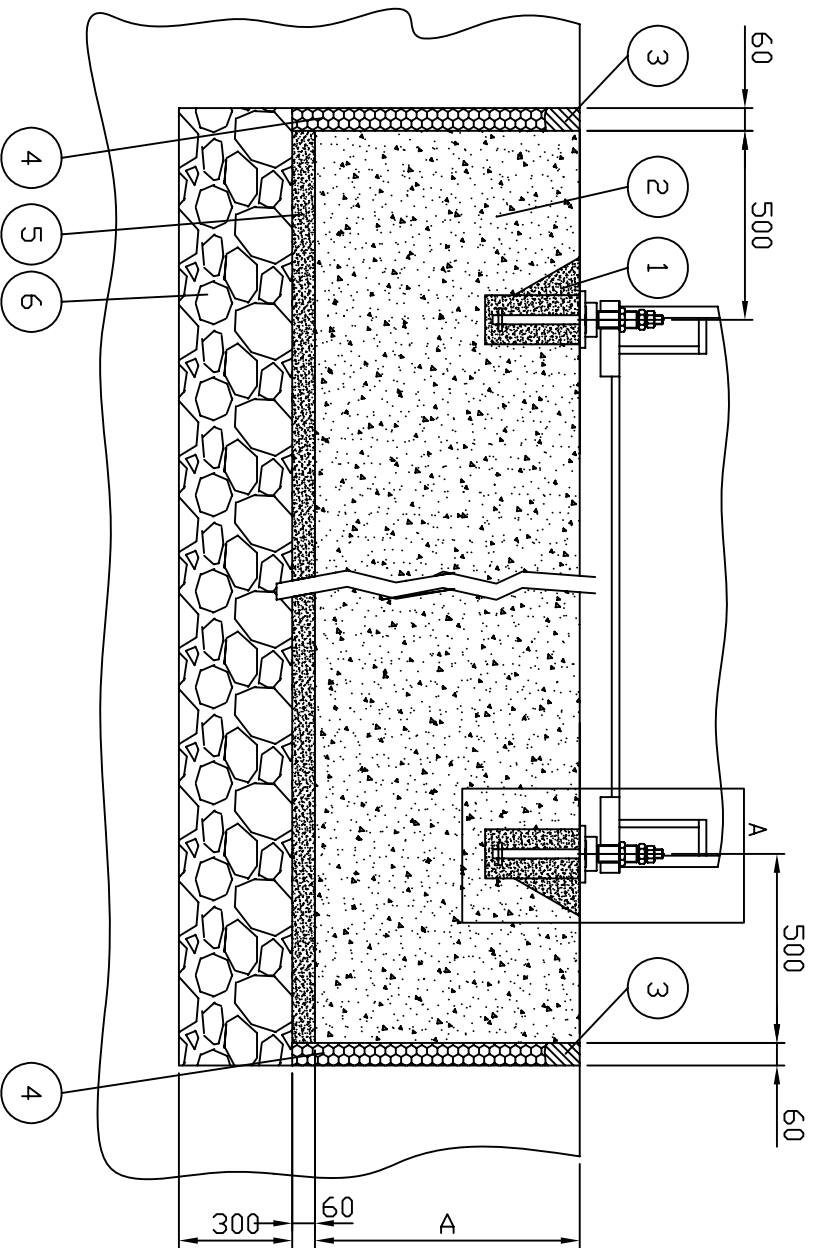

- 1> Concrete 5000pci
- 2> concrete 3000pci
- 3> Anti-oil/heat branze
- 4> Anti-vibration polyfoam
- 5> Anti-vibration sand
- 6> Round-shaps ston Dia 150~300

Leaderway Machinery Co. Ltd.

Scale 1:20 Drawing Name PROCESS OF SETTING (地基施工圖) Page 1/2 **A4**

Drawn	Name	Date	Draw No.
Control	jack	96. 11. 20	8150198B0 (全機型)
	jack	96. 11. 20	

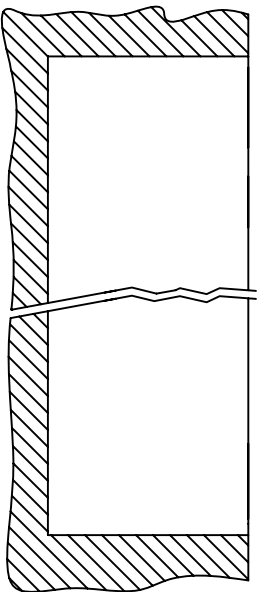

According to foundation drawing set the foundation area

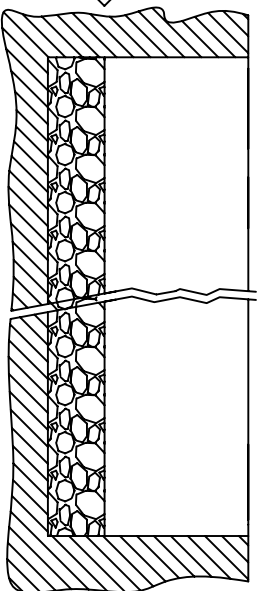

Firste, put stones on the bottom
stone dia 10mm~300mm

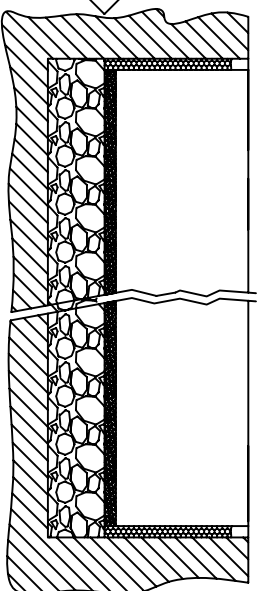

Fill up the sand and styrofoam plate on the other side

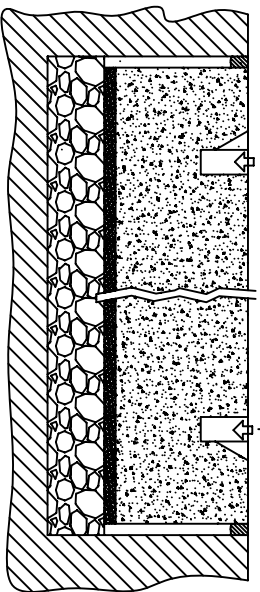

hoist machine higher and install the anchor bolts

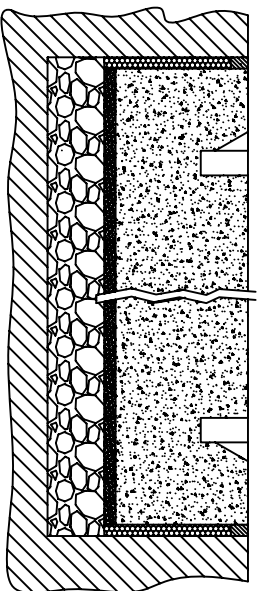

Dig out the hole of anchor bolts

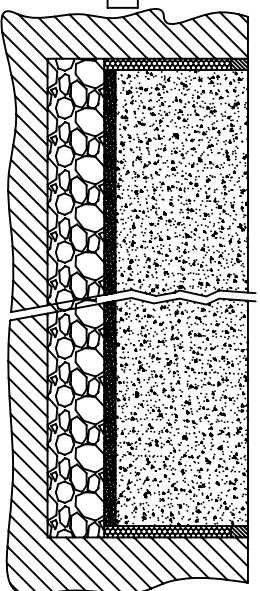

Put the oil-proof and anti-heat stripe on the other side, then fill up the cement(3000pci0
Harden time about 7~10 days

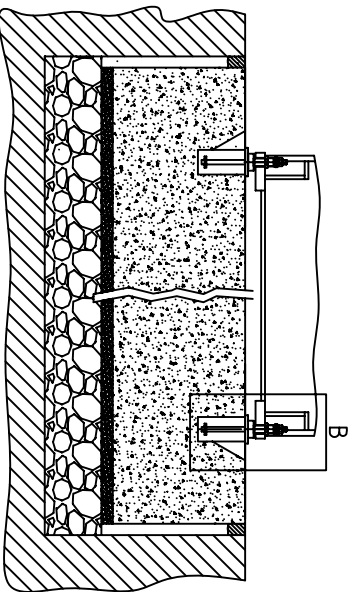

Put whole machine into the position

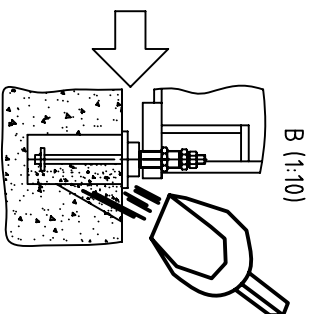

Fill up with 5000pci cement
harden time about 3~5 days

Leaderway Machinery Co. Ltd.

Scale

1:20

Drawing Name

PROCESS OF SETTING (地基施工圖)

Page

2/2

A4

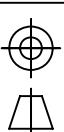

Drawn

jack

Control

jack

Date

96. 11. 20

Date

96. 11. 20

Draw No.

8150198B0 (全機型)

7	High-Pressure oil hose	1	1/8"PT R1 610mm	
6	Automatic piston lubricator	1	4 ports	
5	Automatic piston lubricator	1	3 ports	
4	Automatic piston lubricator	2	5 ports	
3	Equal tee	2	PKD-06(ϕ 6)	
2	Flexible metal hose	1	ϕ 6*600L	
1	Automatic piston lubricator	1	CEVB-03/220V	
Item	Description	Q, ty	Standard	Material

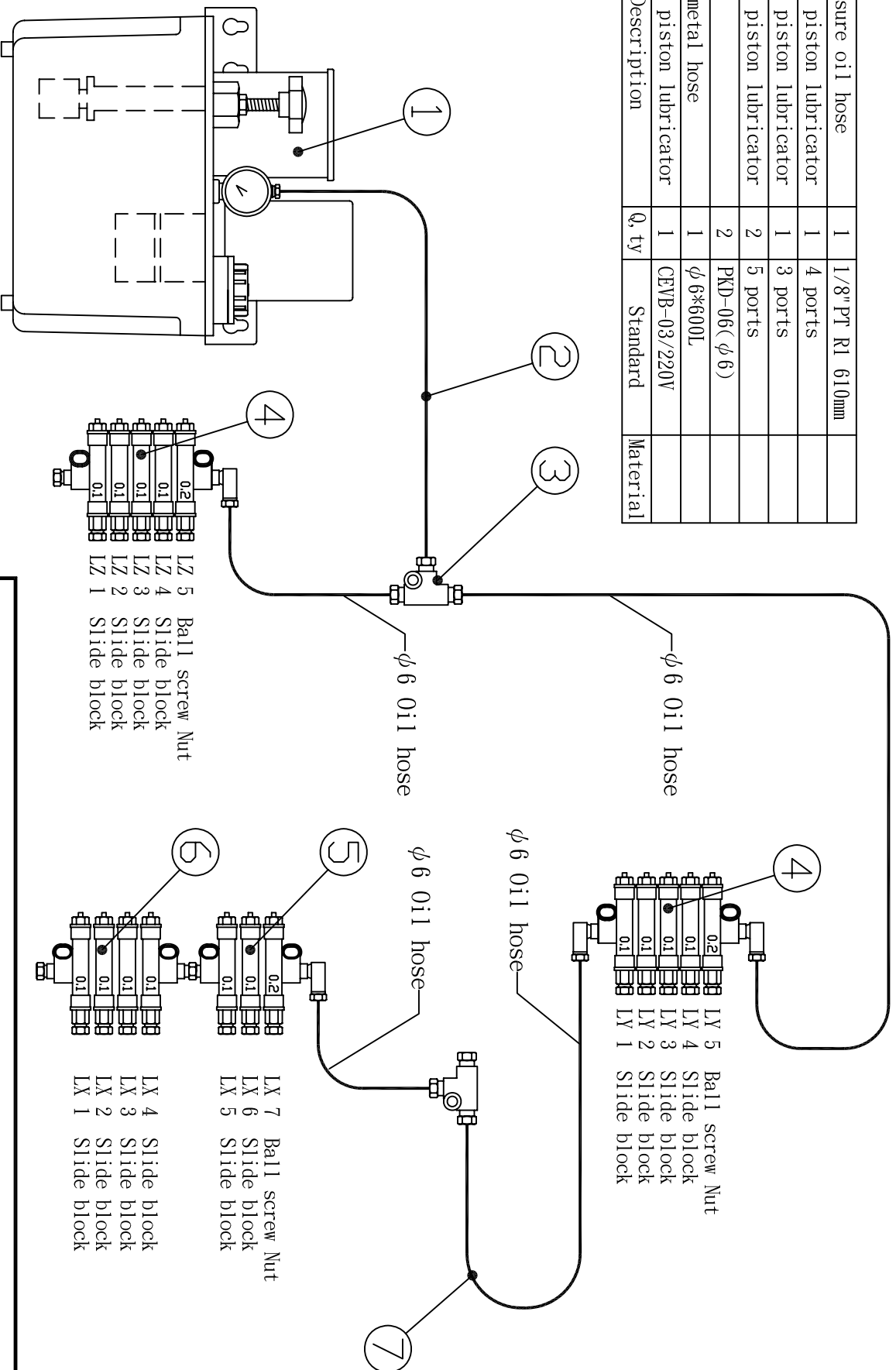

Suitable Type: V-42i W

Leaderway Machinery Co. Ltd.

Scale 1:4
 Drawing Name 潤滑油路配件組合圖
 LUBRICATION ASSEMBLY DIAGRAM
 Page 1/1 A4

Drawn 卜焜云
 Checked 卜焜云
 Date 101.03.12
 Draw No. 8150249A0 (V42i W)

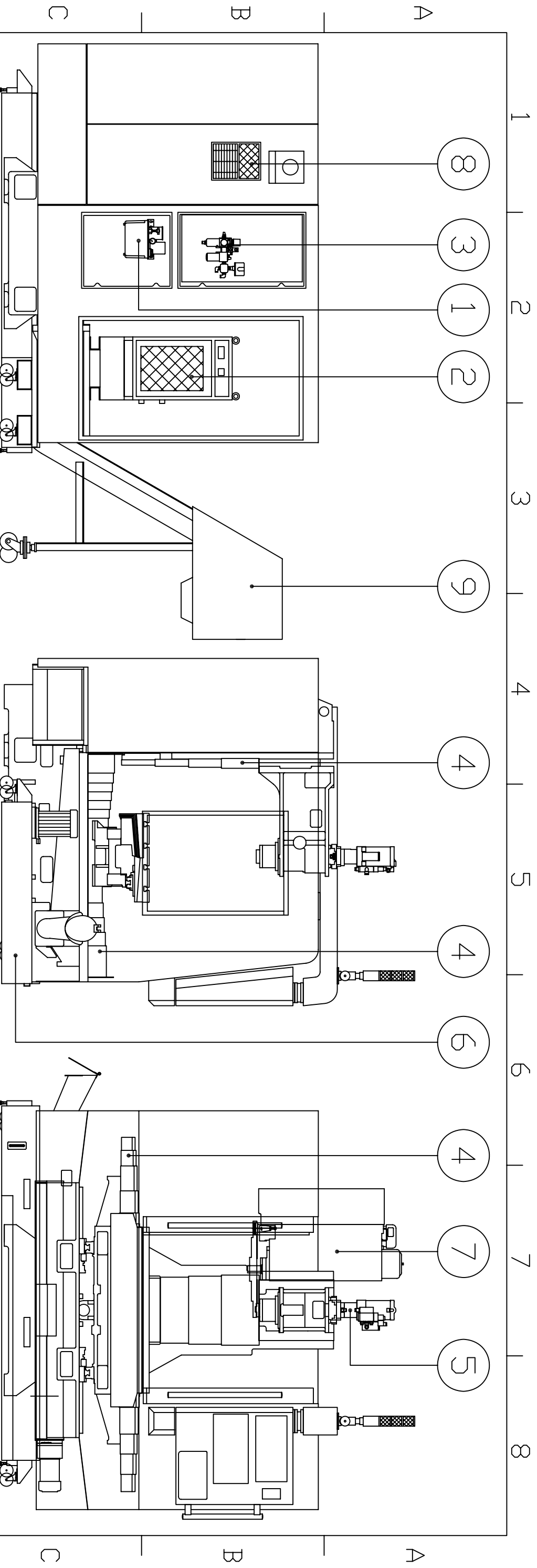

OPERATING HOURS	1			2			3			4			5			6			7			8			9			10			11					
	POINT N°	MAINTENANCE SYMBOL	MACHINE COMPONENT	POINT N°	MAINTENANCE SYMBOL	MACHINE COMPONENT	POINT N°	MAINTENANCE SYMBOL	MACHINE COMPONENT	POINT N°	MAINTENANCE SYMBOL	MACHINE COMPONENT	POINT N°	MAINTENANCE SYMBOL	MACHINE COMPONENT	POINT N°	MAINTENANCE SYMBOL	MACHINE COMPONENT	POINT N°	MAINTENANCE SYMBOL	MACHINE COMPONENT	POINT N°	MAINTENANCE SYMBOL	MACHINE COMPONENT	POINT N°	MAINTENANCE SYMBOL	MACHINE COMPONENT	POINT N°	MAINTENANCE SYMBOL	MACHINE COMPONENT						
DAILY MAINTENANCE			LUBRICATION UNIT			REFRIGERATION UNIT			AIR TREATMENT UNIT			X-Y-Z TELESCOPIC COVER			FIGHTING KNIFE DEVICE			COOLING UNIT			TOOL MAGAZIN			HEAT EXCHANGER			CHIP CONVEYOR			GEAR BOX			HYDRAULIC UNIT			
CHECK ITEMS	1	2	3	1	2	3	1	2	3	1	2	3	1	2	3	1	2	3	1	2	3	1	2	3	1	2	3	1	2	3	1	2	3			
MANUALLY LUBRICATION	8		8						8																											
CHECK																																				
CHANGE																																				
CLEAN AND LUBRICATE																																				
CHECK AND FILL		8				200																														
DRAIN AND REFILL																																				
TYPE OF LUBRICANT (STANDARD ISO 3498)		VG-68				VG-22			VG-22			VG-68			VG-32			⊕																		

ATTENTION: CLEAN ALL THESE POINTS THOROUGHLY BEFORE LUBRICATION

⊕ MOBILCUT 232-CONCENTRATION 7% MAXI. (PLEASE REFER TO END USER'S SUPPLIER MANUAL)

The machine part accessories listed above does not exactly accord with your sales order. Please refer to your sales order if any machine parts accessories differences.

Leaderway Machinery Co. Ltd.

Scale	1:23	Drawing Name	V-33i/V-42i 每日保養表	Page	1/1
			V-33i/V-42i THE SKETCH OF DAILY MAINTENANCE		A3
Drawn	卜根云	Date	99.03.18	Draw No.	8150047C0
Control					

1 2 3 4 5 6 7 8

A B C D E F

97/12

台灣力得衛宇龍科技股份有限公司

*單階材料用量清單

製表日期: 101-03-30

第1頁

主件品號	序號	元件品號	品名 英文品名	規 格	月量
2F11051			主軸頭+立柱單元 SPINDLE HEAD + COLUMN UNIT	V42iW	
	0010	3500010B0	調整檔塊 ADJUSTABLE STOPPER	3140\SS41	2
	0020	3500012B0	滑座壓塊 SLIDING BLOCK,ADJUSTABLE BRA	3210\SS41	4
	0030	3582170A0	主軸頭 SPINDLE HEAD	1010\3582170A2\FC30	1
	0040	3582171A0	立柱 COLUMN	1020\3582171A2\FC-30	1
	0050	3582196A0	Z軸下摺動罩 LOWER TELESCOPIC COVER, Z	9400\SPCCZ	1
	0060	3582197A0	Z軸防屑擋板 PLATE FOR CHIP	7210\	2
	0070	3582198A0	碰塊座支撐架 RIGHT DOG BRACKET SUPPORTER	SS41	1
	0080	3582199A0	微動開關座(Z) MICRO SWITCH BRACKET, Z AXIS	3160\SS41	1
	0090	4800143204	微動開關 MICRO SWITCH	BNS819-B02-D12-61-12-10BALLU	1
	0100	3500082B0	碰塊座 DOG BRACKET	4140\AL(125m/m*3軌)	2
	0110	3500081A0	碰塊 DOG	3140\SS41(42m/m)	2
	0120	3540007A0	碰塊 DOG	4140\AL 外購65L	1
	0130	3985075A0	線性滑軌-Z軸 LINEAR GUIDE	9840\#35滾柱型	1
	0140	4080106015	直銷(軸承鋼針) PIN	φ 6x15L	58
	0150	3582201A0	主軸頭右側蓋板 RIGHT COVER, SPINDLE HEAD	7510\SPCC	1
	0160	3582202A0	主軸頭左側蓋板 LEFT COVER, SPINDLE HEAD	7510\SPCC	1
	0170	3582203A0	主軸頭前蓋板 FRONT COVER, SPINDLE HEAD	7510\SPCC	1
	0180	3582204A0	主軸聯動管支架 CONDUIT BRACKET	7210\SPCC	1
	0190	3582205A0	主軸頭側壓克力板 ACRYLIC PLATE, SIDE OF SPIND	4360\ACRY	1
	0200	3582200A0	主軸頭右側架 RIGHT BRACKET, SPINDLE HEAD	7510\SPCC	1
	0210	3582206A0	主軸頭外側蓋板 SIDE COVER, SPINDLE HEADSTOCK	7510\SPCC	1
	0220	4640065133	方型聯動管 WIRE CONDUIT	KY-CE(CBS65.2)-65x133-(22目)	1
	0230	4210550003	總流量控制組 COOLANT NOZZLE MANIFOLD	JTM-01控制組\5/8"插心	1
	0240	3500063B0	近接開關座 PROXIMITY SWITCH BRACKET	7160\SPCC	1
	0250	3990144A0	刀具釋放指示牌 NAME PLATE	4350\AL	1

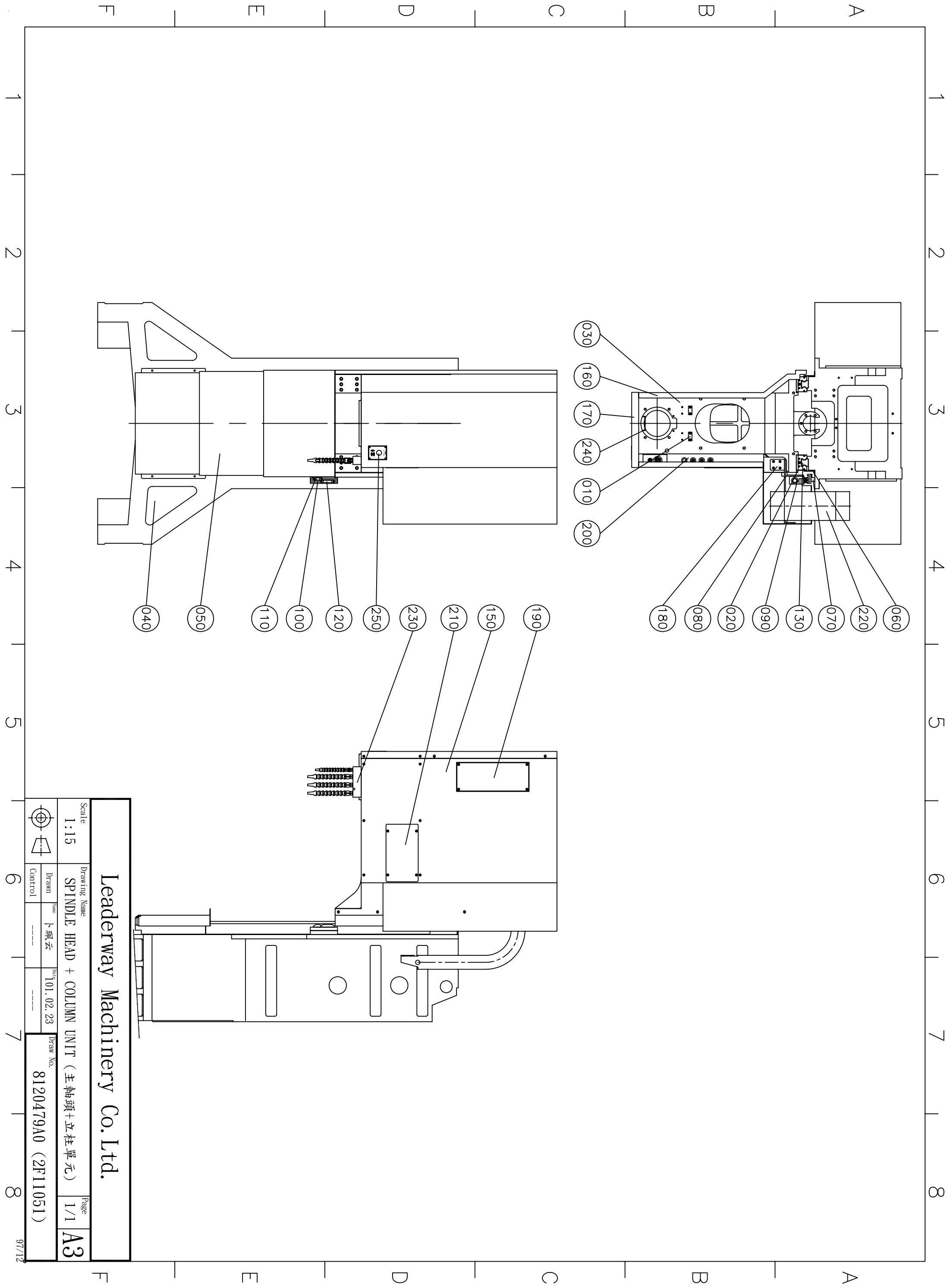

Leaderway Machinery Co. Ltd.

Scale		Drawing Name		Page	
1:15		SPINDLE HEAD + COLUMN UNIT (主軸頭+立柱單元)		1/1	
Drawn	Name	Date	Draw No.	A3	
Control	卜根云	101.02.23	8120479A0 (2F11051)		

台灣力得衛宇龍科技股份有限公司

*單階材料用量清單

製表日期: 101-03-30

第1頁

主作品號	序號	元作品號	品名 英文品名	規 格	月量
2F16015			配重單元 COUNTER BALANCE UNIT	V42iW	
	0010	3582190A0	配重 COUNTER BALANCE	3070\SS41	1
	0020	3500006C0	鏈輪軸固定座 SPROCKET SHAFT BRACKET	1210\FC-25\3500006A2	2
	0030	3500021A0	鏈條滾輪 ROLLER	3260\S45C	4
	0040	3500022C0	鏈輪軸 SHAFT SPROCKET	3260\S45C	4
	0050	4060700025	C型扣環(軸用) C TYPE RETAINER RING	S-25	8
	0060	4400206205	深槽滾珠軸承 BEARING	6205ZZ	8
	0070	3500416A0	配重滑塊 SLIDING BLOCK,COUNTER BALANC	4370\MC	2
	0080	3582191A0	配重導桿 GUIDING ROD, COUNTER BALANCE	4290\圓棒	1
	0090	4062006025	軸心固定座 SHAFT BRACKET	SHF25-M6	1
	0100	3500418C0	滑軌下固定板 LOWER FIXED PLATE, GUIDING R	7180\SPCC	1
	0110	3582192A0	滑軌上固定板 UPPER FIXED PLATE, GUIDING R	7180\SPCC	1
	0120	3582193A0	滑軌上固定板支架 BRACKET FOR UPPER FIXED PLAT	7180\SPCC	1
	0130	3582194A0	鏈條保護蓋(左) PROTECTING COVER FOR CHAIN	7510\SPCC	1
	0140	3582195A0	鏈條保護蓋(右) PROTECTING COVER FOR CHAIN	7510\SPCC	1
	0150	3500023A0	鏈條連結螺絲 CHAIN CONNECTING BOLT	4310\SCM4	4
	0160	4610050073	鏈條 CHAIN	50x73P (含2鏈目)	2

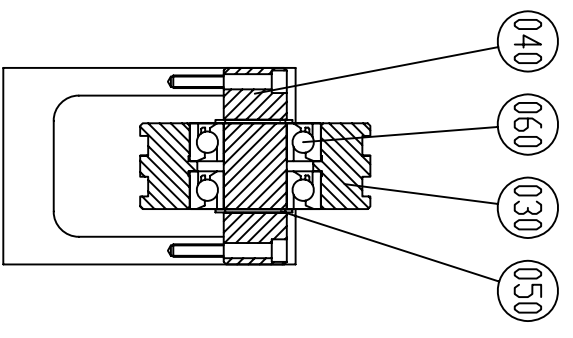
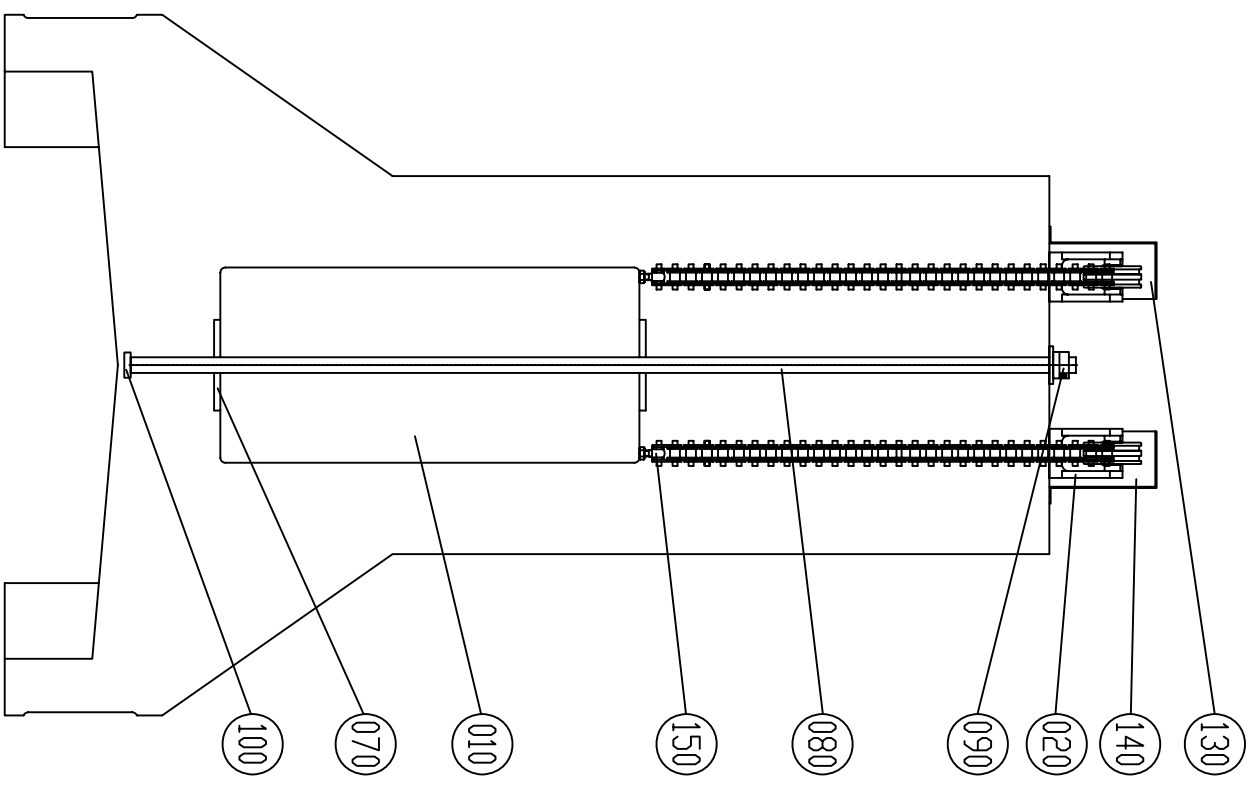

比例 1:3

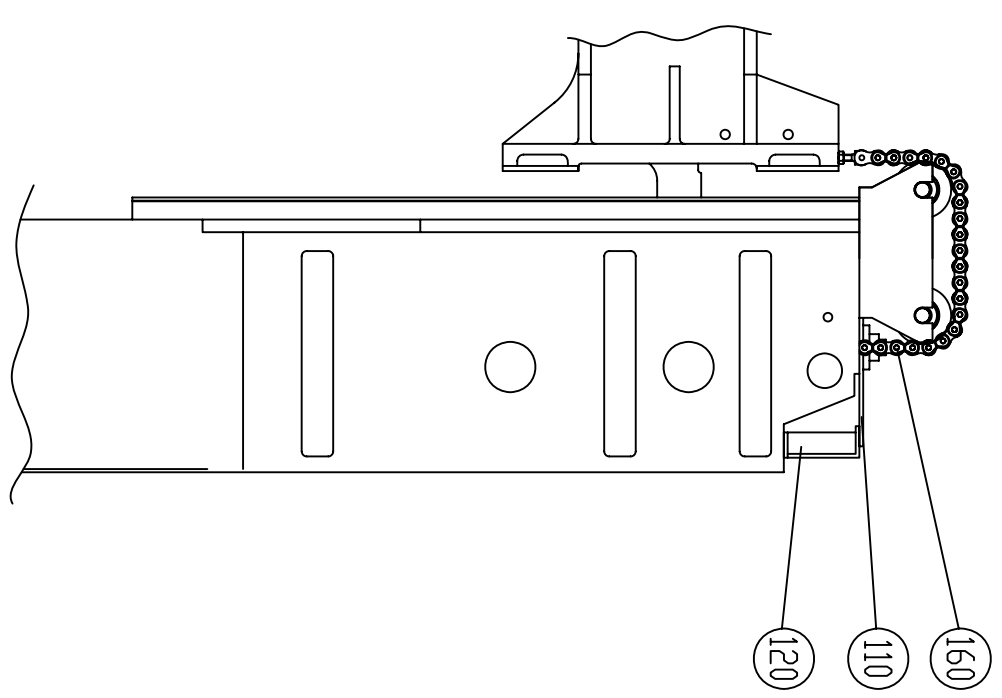

Leaderway Machinery Co. Ltd.

Scale 1:12	Drawing Name V-42i W 配重單元 V-42i W COUNTER BALANCE UNIT	Page 1/1
Drawn Control	Name 卜珮云	Draw No. 8120481A0 (2F16015)
	Date 101.02.29	Page A4

台灣力得衛宇龍科技股份有限公司

*單階材料用量清單

製表日期: 101-03-30

第1頁

主件品號	序號	元件品號	品名 英文品名	規 格	月量
2F27004			打刀單元 BOSSTING CYLINDER UNIT	V450/V33i/V42i	
	0011	3500008B0	增壓缸固定座 TOOL RELEASE CYLINDER BRACKE	3180\SS41	1
	0021	3500009B0	浮動打刀拉座 TOOL RELEASE CYLINDER SEAT	3250\S45C	1
	0031	3500019B0	固定軸套 FIXED ROD	3290\S45C	4
	0040	3980001A0	增壓缸(3Tx13L) TOOL RELEASE CYLINDER	9880	1

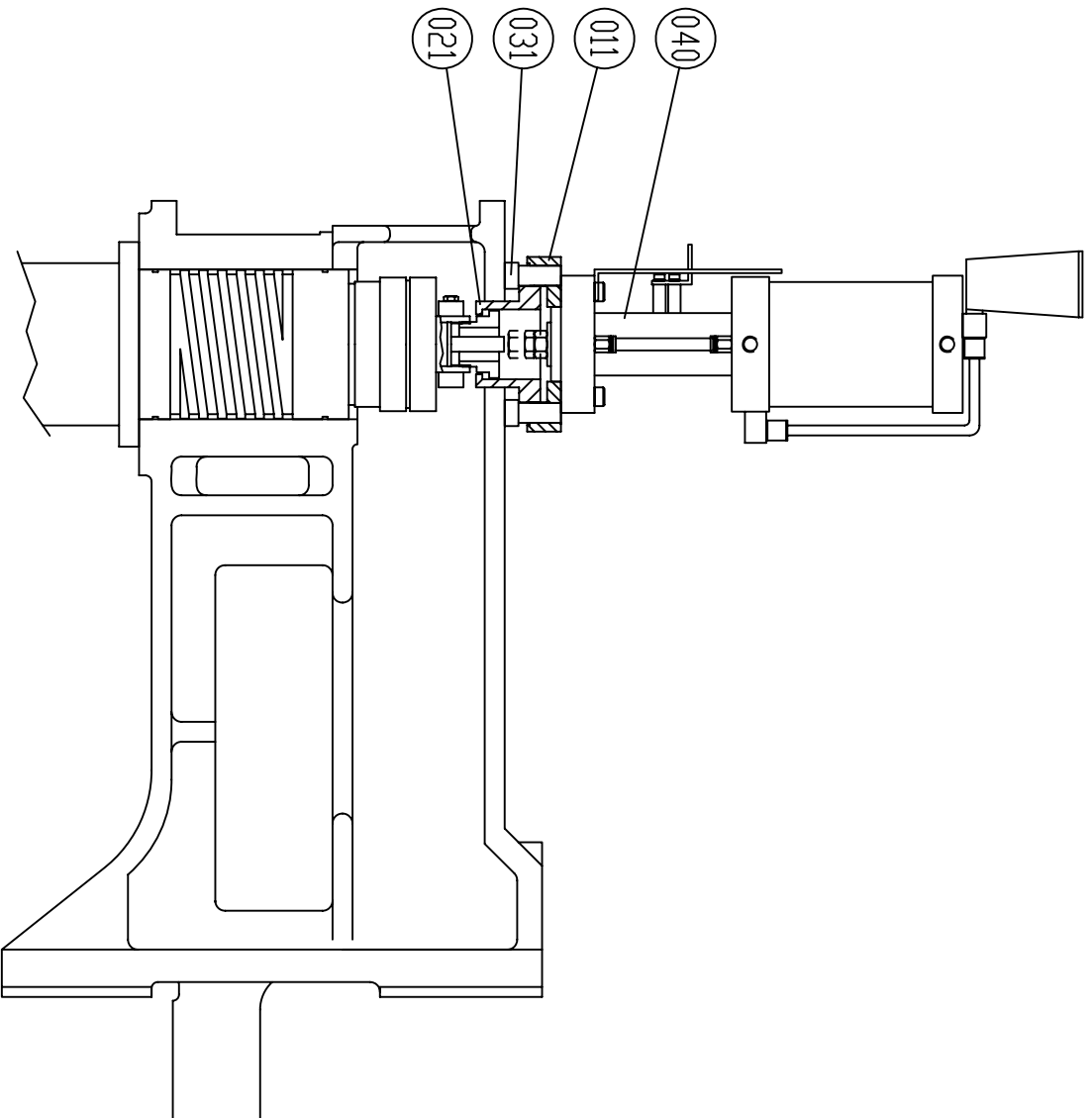
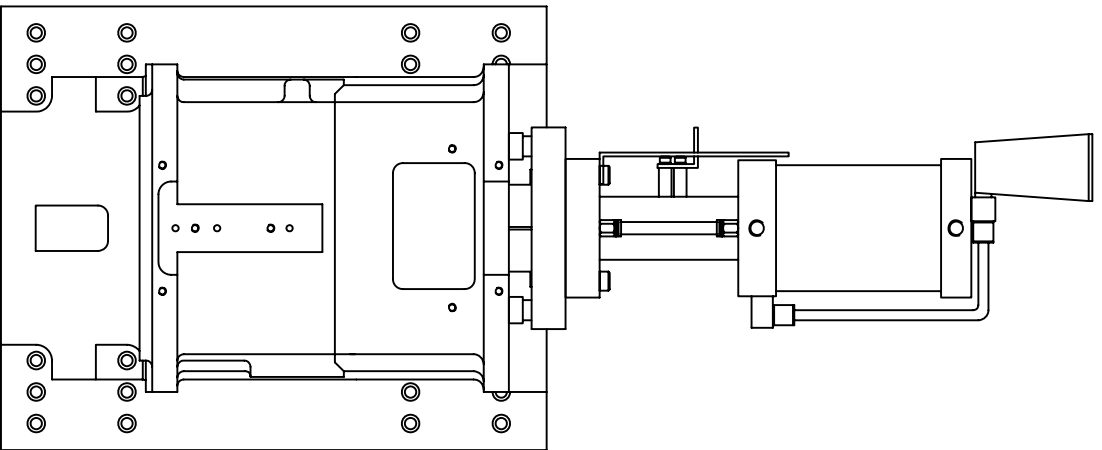

Leaderway Machinery Co. Ltd.

Scale

1:6

Drawing Name

打刀單元
BOSTING CYLINDER UNIT

Page

1/1

A4



Drawn

張靜宜

Control

Date

97.11.07

Draw No.

8120207B0 (2F27004)

台灣力得衛宇龍科技股份有限公司

*單階材料用量清單

製表日期: 101-03-30

第1頁

主件品號	序號	元件品號	品名 英文品名	規 格	月量
2F28046			主軸皮帶輪單元 SPINDLE BELT UNIT	V42iW/SJ-V15-01ZT-S02(F)	
	0010	3500011B0	主軸馬達固定板 FIXED PLATE FOR MOTOR	3170\SS41	1
	0020	3971061A0	齒型皮帶輪 PULLEY	3270\S45C染黑\5GT-72T\φ66	1
	0030	3600135A0	軸壓蓋(φ48) SHAFT END COVER	3240\S45C	1
	0040	4061248055	迫緊環 PACKING RING	TLK300 48x55	2
	0050	4601035920	齒型皮帶(剖溝) PULLEY BELT	5GT*35*920	1

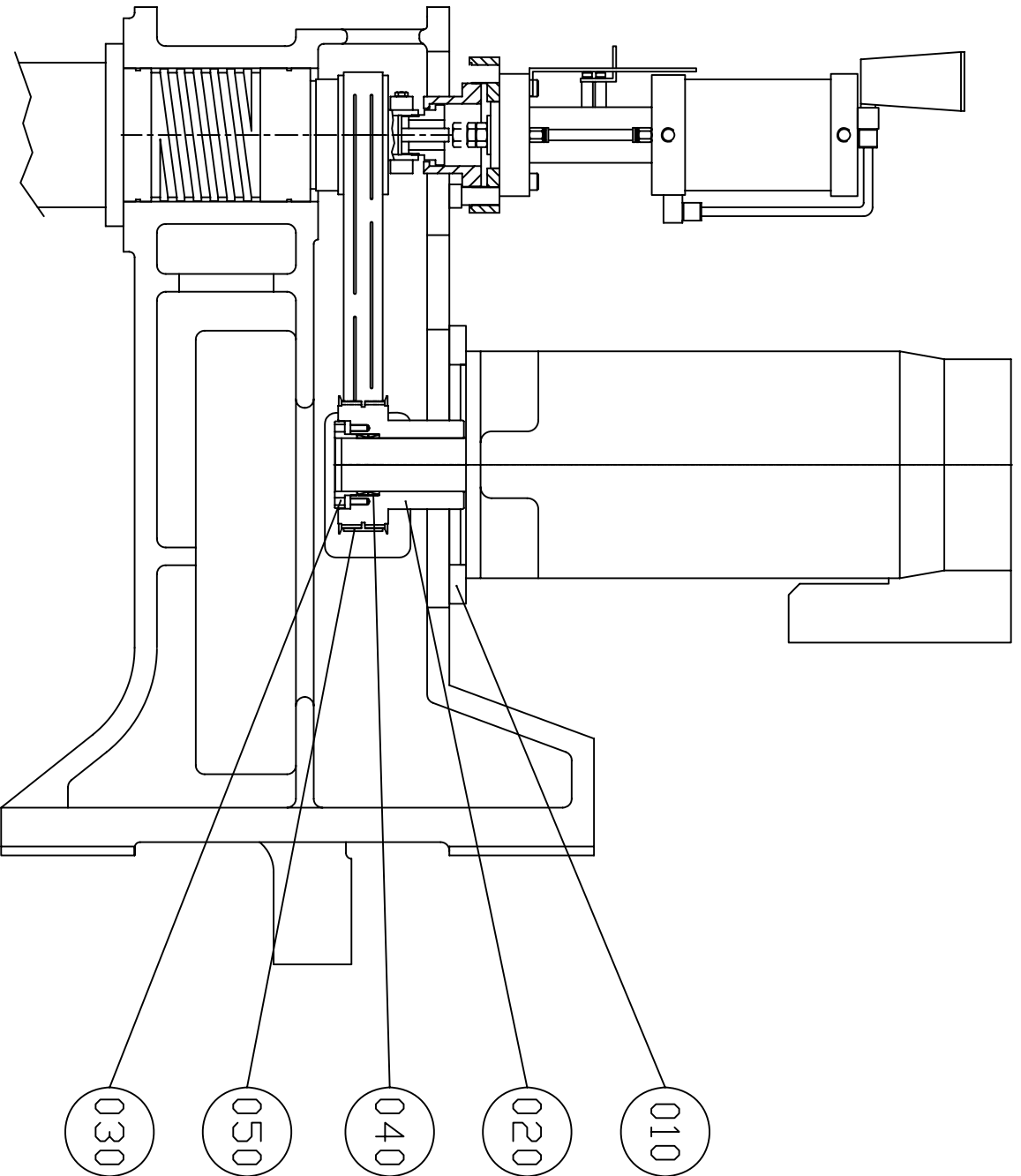

Leaderway Machinery Co. Ltd.

Scale		Drawing Name		Page	
1:6		主軸皮帶輪單元 (三菱 70M) SPINDLE BELT UNIT (MITSUBISHI 70M)		1/1	
Drawn		Name		A4	
Control		卜 珮 云		8120490A0 (2F28046)	
		Date		Draw No.	
		101.03.07			

台灣力得衛宇龍科技股份有限公司

*單階材料用量清單

製表日期: 101-03-30

第1頁

主件品號	序號	元件品號	品名 英文品名	規 格	月量
2F28047			主軸皮帶輪單元 SPINDLE BELT UNIT	V42iW/β8i*8000rpm	
	0010	3500011B0	主軸馬達固定板 FIXED PLATE FOR MOTOR	3170\SS41	1
	0020	3971008A0	齒型皮帶輪(5GT-75T) PULLEY	3270\S45C	1
	0030	3580161A0	馬達軸端蓋 SHAFT END COVER	3170\S45C	1
	0040	4061232036	迫緊環 PACKING RING	TLK300 32x36	2
	0050	4601035935	齒型皮帶(剖溝) PULLEY BELT	5GT*35*935mm	1

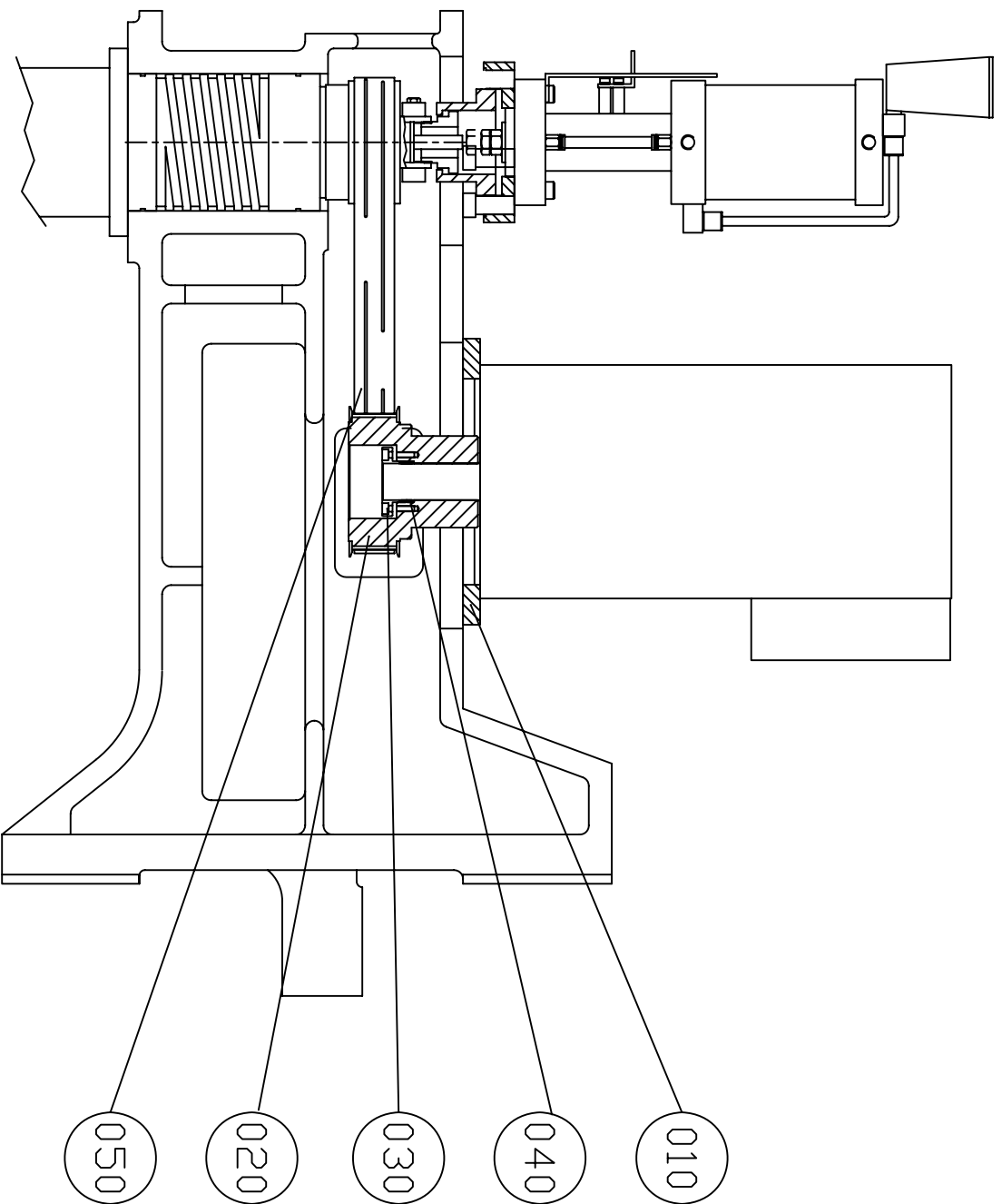

Leaderway Machinery Co. Ltd.

Scale		Drawing Name		Page	
1:6		主軸皮帶輪單元 (FANUC β8i) SPINDLE BELT UNIT (FANUC β8i)		1/1	
Drawn		Date		Draw No.	
Control		卜佩云		8120485A0 (2F28047)	
		Date			
		101.03.01			
				A4	

台灣力得衛宇龍科技股份有限公司

*單階材料用量清單

製表日期: 101-03-30

第1頁

主件品號	序號	元件品號	品名 英文品名	規 格	用量
2F13026			底座+鞍座+工作台單元 BASE + SADDLE + TABLE UNIT	V42iW	
	0010	3582172A0	底座 BASE	1030\3582172A2\FC-30	1
	0020	3580410A0	地基螺絲(M36*2P) FOUNDATION BOLT	3310\S45C	6
	0030	3580411A0	地基螺帽(M36*2P) FOUNDATION BOLT	3310\S45C	6
	0040	3600047B0	墊塊(地基螺絲) FOUNDATION PAD	3230\S45C	6
	0050	3582001A0	噴水座 NOZZLE TUBE BRACKET	3150\SS41	2
	0060	3582184A0	大護罩前支架 FRONT BRACKET, GUARD	7210\SPCC	2
	0070	3582212A0	導油槽 OIL TROUGH	7520\SPCC	1
	0080	3582173A0	鞍座 SADDLE	1040\FC-30	1
	0090	3985073A0	線性滑軌-Y主 LINEAR GUIDE	9840\市購品	1
	0100	3985074A0	線性滑軌-Y副 LINEAR GUIDE	9840\市購品	1
	0110	3582006A0	壓塊 SLIDING BLOCK	4120	106
	0120	3582183A0	螺絲襯套 BUSHING	4230\不鏽鋼	8
	0130	3582185A0	Y軸前摺動罩 Y AXIS TELESCOPIC COVER UNIT	7400\SPCCZ	1
	0140	3582186A0	Y軸後摺動罩 Y AXIS TELESCOPIC COVER UNIT	7400\SPCCZ	1
	0150	3582187A0	Y軸摺動罩支架(上) TELESCOPIC COVER BRACKET	7210\SPCC	2
	0160	3582188A0	Y軸摺動罩支架(下) TELESCOPIC COVER BRACKET	7210\SPCC	2
	0170	3582189A0	鞍座下擋屑板 BAFFLE PLATE	7510\SPCC	2
	0180	3582245A0	聯動管連結座 CONDUIT BRACKET	7210\SPCC	1
	0190	4640015090	方型聯動管 WIRE CONDUIT	CECBO02-26x58-222(15P)/R90	1
	0200	3500081A0	碰塊 DOG	3140\SS41(42m/m)	4
	0210	3500082B0	碰塊座 DOG BRACKET	4140\AL(125m/m*3軌)	1
	0220	3500083A0	碰塊座 DOG BRACKET	4140\AL(90m/m*3軌)	1
	0230	3540007A0	碰塊 DOG	4140\AL 外購65L	2
	0240	3581032B0	碰塊座 DOG BRACKET	4140\AL(300m/m*2軌)	2
	0250	4800143204	微動開關 MICRO SWITCH	BNS819-B02-D12-61-12-10BALLU	2
	0260	3582168B0	微動開關固定座-Y上 SWITCH BRACKET	7160\SPCC	1
	0270	3582169B0	微動開關固定座-Y下 SWITCH BRACKET	7160\SPCC	1
	0280	3582174A0	工作台 TABLE	1050\3582174A2\FC-30	1
	0290	3581025D0	螺帽座 BALLSCREW HOUSING	1080\FC-25\3581025A2	1
	0300	3560121B0	塞頭(工作台) TABLE SEALED CORK	3310\SS41	16

<續下頁>

台灣力得衛宇龍科技股份有限公司

*單階材料用量清單

製表日期: 101-03-30

第2頁

主作品號	序號	元作品號	品名 英文品名	規 格	月量
2F13026	0310	3985050A0	X軸線性滑軌 LINEAR GUIDE	BRH35AL2-P-ZZ-L1800 II	1
	0320	3582179A0	X軸摺動罩 X AXIS TELESCOPIC COVER UNIT	7400\SPCCZ	2
	0330	3582180A0	X軸摺動罩上支架 TELESCOPIC COVER BRACKET	7180\SPCC	4
	0340	3582181A0	X軸摺動罩支架(左) TELESCOPIC COVER BRACKET	7180\SPCC	2
	0350	3582182A0	X軸摺動罩支架(右) TELESCOPIC COVER BRACKET	7180\SPCC	2
	0360	3582175A0	碰塊座連結塊(X) CONDUIT FOR DOG(X)	3180\SS41	2
	0370	3582176A0	微動開關座(X) MICRO SWITCH BRACKET, X AXIS	7160\SPCC	1
	0380	3582178A0	工作台後飾板 REAR PLATE, TABLE	7510\SPCC	1
	0390	3582177A0	工作台前飾板 FRONT PLATE, TABLE	7510\SPCC	1
	0400	3582065C0	X軸分油座 OIL DISTRIBUTOR BRACKET	7210\SPCC	1
	0410	3582079B0	油分配器座(Y軸) DISTRIBUTOR BRACKET	7210\SPCC	1
	0420	4640028849	塑鋼製鏈條式聯動管 ELECTRICAL CONDUIT UNIT		1

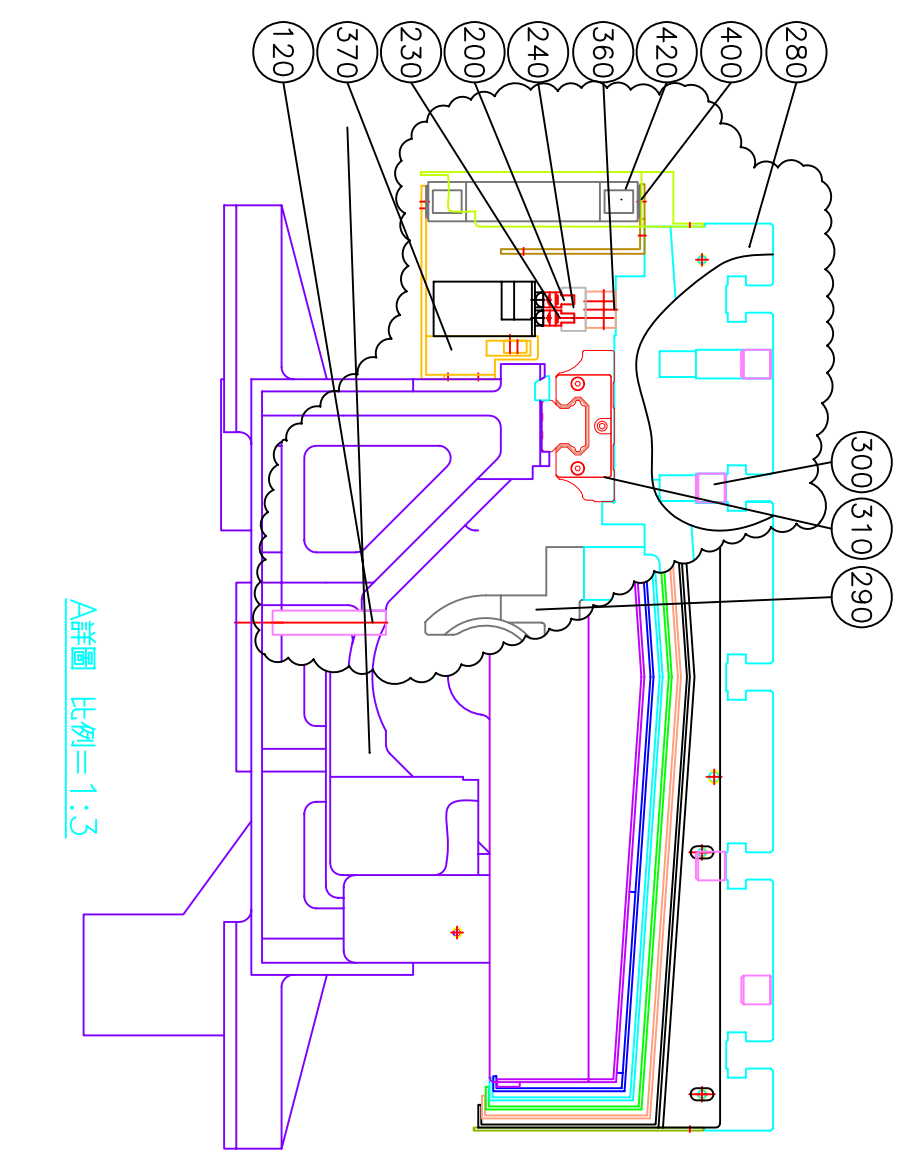
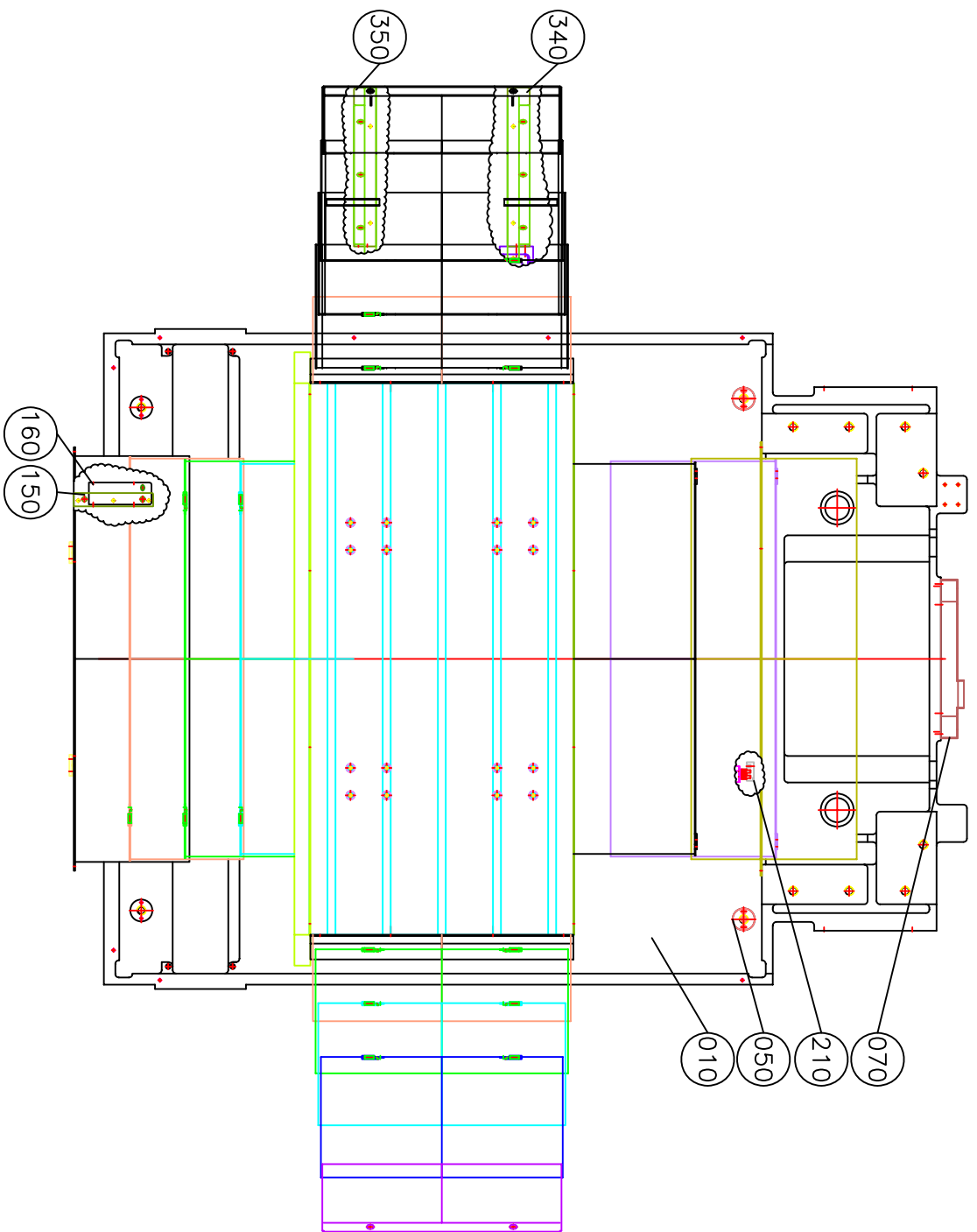

A詳圖 比例=1:3

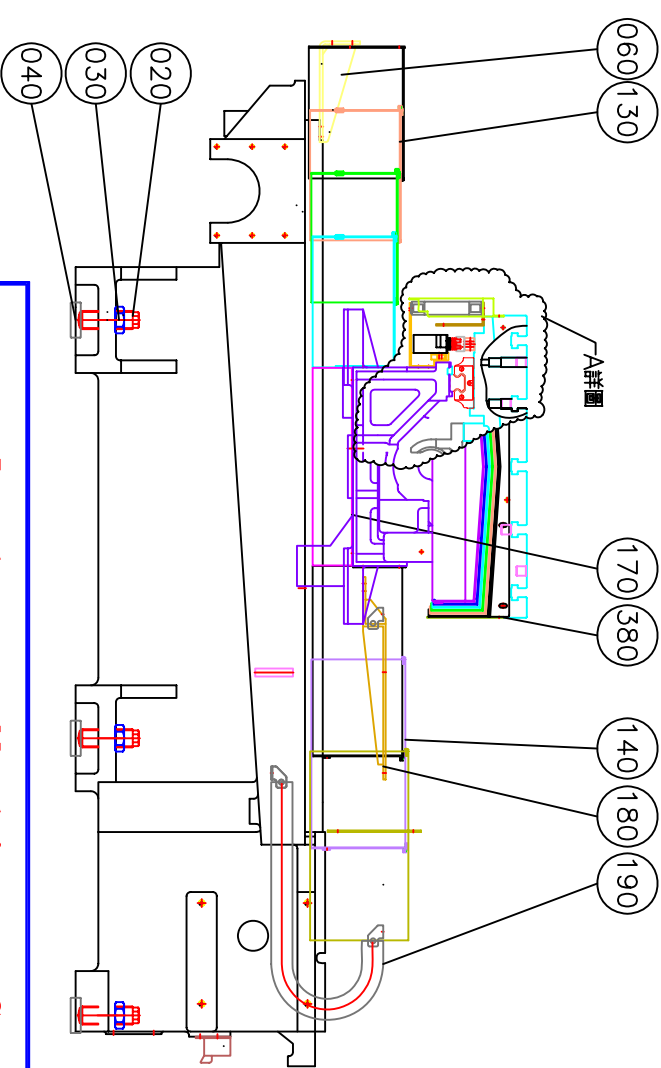
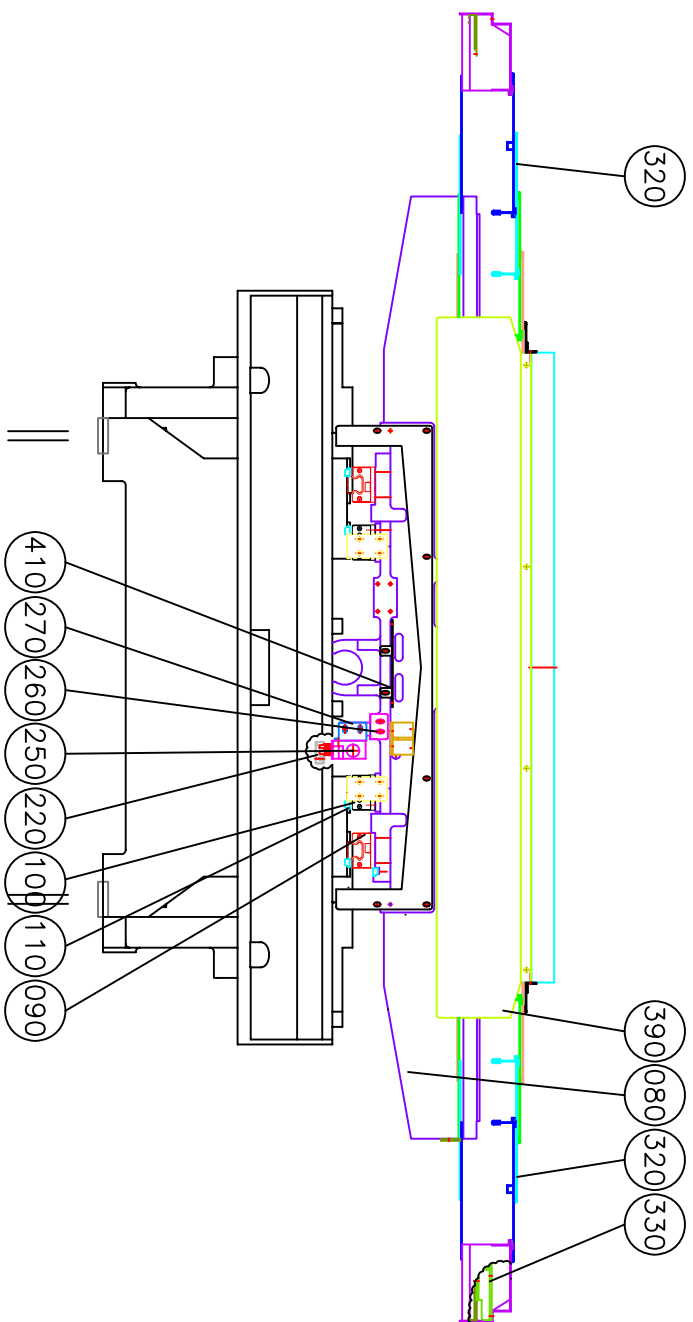

Leaderway Machinery Co. Ltd.

Scale 1:15
 Drawing Name BASE+SADDLE+TABLE UNIT (底座+鞍座+工作臺單元) Page 1/1
A3

Drawn 翁氣榮 Date 101.02.29 Draw No. 8120480A0



Control

8120480A0

台灣力得衛宇龍科技股份有限公司

*單階材料用量清單

製表日期: 101-03-30

第1頁

主件品號	序號	元件品號	品名 英文品名	規 格	月量
2F21028			X軸傳動單元 X AXIS TRANSMISSION UNIT	V42iW	
	0010	3170053B0	軸承隔環 BEARING SPACER	3230\SCM4	1
	0020	3170054B0	前迷宮環座 LAMINAL RING BRACKET	3250\SCM4	2
	0030	3170057B0	軸承隔環 BEARING SPACER	3230\SCM4	1
	0040	3170067A0	預拉彈簧檔片 PRELOAD SPRING STOPPER	3230\S45C	1
	0050	3170070A0	Z軸尾端軸承座 REAR BEARING HOUSING	1080\S45C	1
	0060	3560016B0	軸承壓蓋 BEARING CAP	3240\SCM4	1
	0070	3560017B0	防撞膠塊 RUBBER CUSHION	4370\請改下3560017C0	2
	0080	3560018G0	防撞膠塊固定座 RUBBER CUSHION BRACKET	3240\SCM4	1
	0090	3560019B0	防撞膠固定座 RUBBER CUSHION BRACKET	3230\S45C	1
	0100	3560023F0	Z軸尾端軸承座壓板 PUSHING PLATE,BEARING HOUSI	3120\SCM4	1
	0110	3560132B0	尾端座蓋板 REAR BEARING HOUSING COVER	3180\SPCC	1
	0120	3581022B0	尾端座(X軸) REAR BEARING HOUSING	1080\FC-25\3581022B2	1
	0130	3581027B0	傳動座 TRANSMISSION HOUSING	1080\FC-25\3581027B2	1
	0140	3984063A0	滾珠導螺桿(X軸) BALL SCREW	9860\V42iW	1
	0150	4020401030	鎖緊螺帽 LOCK NUT	MK30	1
	0160	4020403035	鎖緊螺帽 LOCK NUT	MF35(M35xP1.5)	1
	0170	4050175012	壓縮彈簧 COMPRESSIVE SPRING	$\phi 1.25 \times \phi 7.5 \times 12L$	8
	0180	4061306828	迷宮環 LAMINAL RING	FK3-AS 62/2.8/0.82	6
	0190	4402030062	螺桿軸承 BALL SCREW BEARING	BS30M62/15-P4A.DUM	1
	0200	4402435072	螺桿軸承 BALL SCREW BEARING	BS35/72/15TUM	1
	0210	3581053A0	傳動座蓋板 TRANSMISSION HOUSING COVER	7180\SPCC	1
	0220	3581092D0	迷宮環座 LAMINAL RING BRACKET	3250\SCM4	1
	0230	4061300001	迷宮環 LAMINAL RING	FK3-AS 68/2.8/0.82	3
	0240	4080508050	斜梢 SLIDE PIN	#8x50L(附內牙)	4

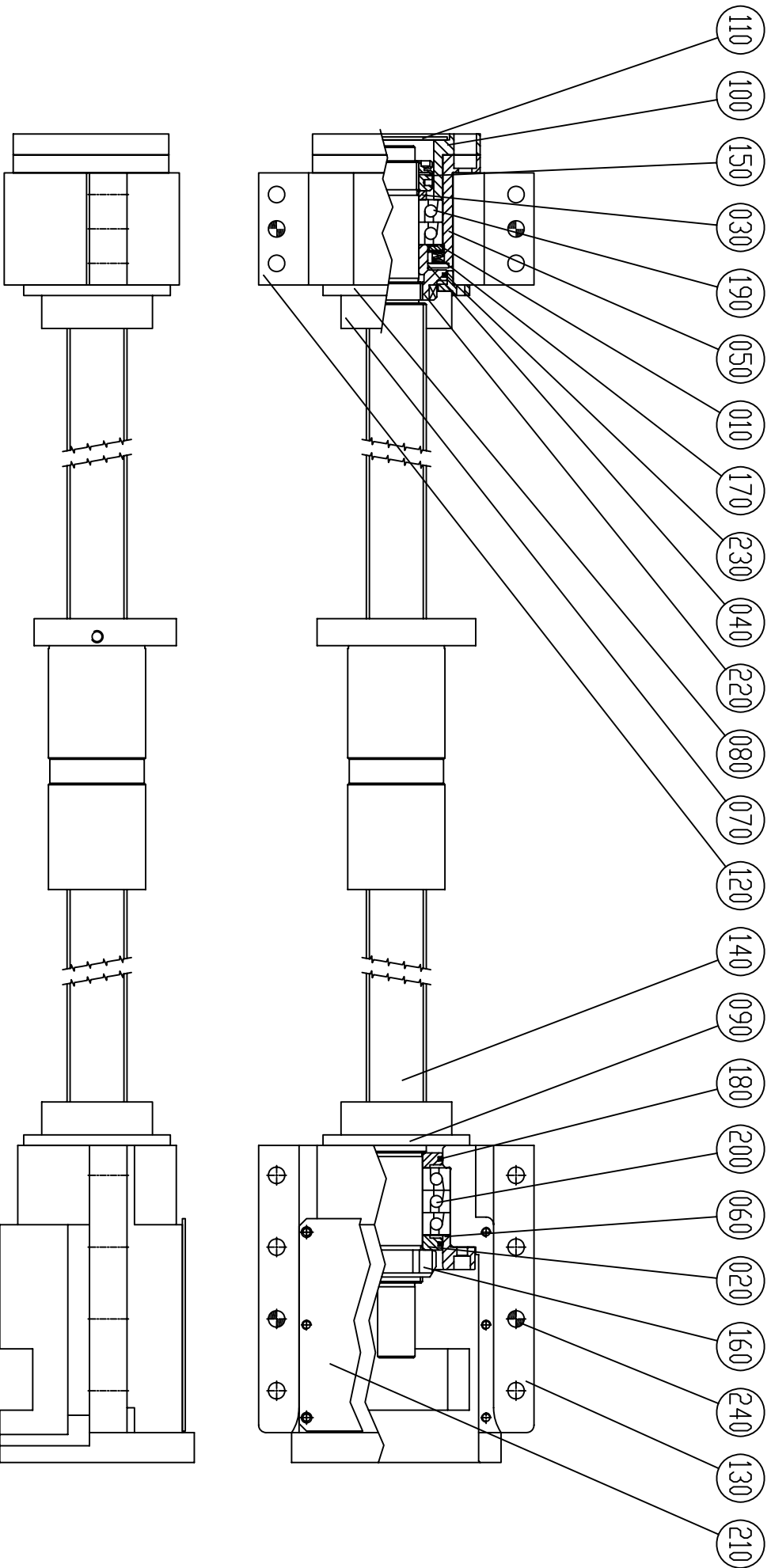

Leaderway Machinery Co. Ltd.

Scale 1:4		Drawing Name V-42i W X軸傳動單元 V-42i W X AXIS TRANSMISSION UNIT		Page 1/1	
Drawn Control		Name 卜珮云		Date 101.02.24	
		Draw No. 8120482A0 (2F21028)		A4	

台灣力得衛宇龍科技股份有限公司

*單階材料用量清單

製表日期: 101-03-30

第1頁

主件品號	序號	元件品號	品名 英文品名	規 格	月量
2F22024			Y軸傳動單元 Y AXIS TRANSMISSION UNIT	V42iW	
	0010	3170053B0	軸承隔環 BEARING SPACER	3230\SCM4	1
	0020	3170054B0	前迷宮環座 LAMINAL RING BRACKET	3250\SCM4	2
	0030	3170057B0	軸承隔環 BEARING SPACER	3230\SCM4	1
	0040	3170067A0	預拉彈簧檔片 PRELOAD SPRING STOPPER	3230\S45C	1
	0050	3170070A0	Z軸尾端軸承座 REAR BEARING HOUSING	1080\S45C	1
	0060	3560016B0	軸承壓蓋 BEARING CAP	3240\SCM4	1
	0070	3560018G0	防撞膠塊固定座 RUBBER CUSHION BRACKET	3240\SCM4	1
	0080	3560019B0	防撞膠固定座 RUBBER CUSHION BRACKET	3230\S45C	1
	0090	3560023F0	Z軸尾端軸承座壓板 PUSHING PLATE, BEARING HOUSI	3120\SCM4	1
	0100	3560132B0	尾端座蓋板 REAR BEARING HOUSING COVER	3180\SPCC	1
	0110	3560374A0	防撞膠塊 RUBBER CUSHION	4370\PU	2
	0120	3581022B0	尾端座(X軸) REAR BEARING HOUSING	1080\FC-25\3581022B2	1
	0130	3581027B0	傳動座 TRANSMISSION HOUSING	1080\FC-25\3581027B2	1
	0140	3984062A0	滾珠導螺桿 BALL SCREW	9860\市購品4150H\Y軸	1
	0150	4020401030	鎖緊螺帽 LOCK NUT	MK30	1
	0160	4020403035	鎖緊螺帽 LOCK NUT	MF35(M35xP1.5)	1
	0170	4050175012	壓縮彈簧 COMPRESSIVE SPRING	φ 1.25X φ 7.5X12L	8
	0180	4061306828	迷宮環 LAMINAL RING	FK3-AS 62/2.8/0.82	6
	0190	4402030062	螺桿軸承 BALL SCREW BEARING	BS30M62/15-P4A.DUM	1
	0200	4402435072	螺桿軸承 BALL SCREW BEARING	BS35/72/15TUM	1
	0210	3581053A0	傳動座蓋板 TRANSMISSION HOUSING COVER	7180\SPCC	1
	0220	3581092D0	迷宮環座 LAMINAL RING BRACKET	3250\SCM4	1
	0230	4061300001	迷宮環 LAMINAL RING	FK3-AS 68/2.8/0.82	3
	0240	4080508050	斜梢 SLIDE PIN	#8x50L(附內牙)	4

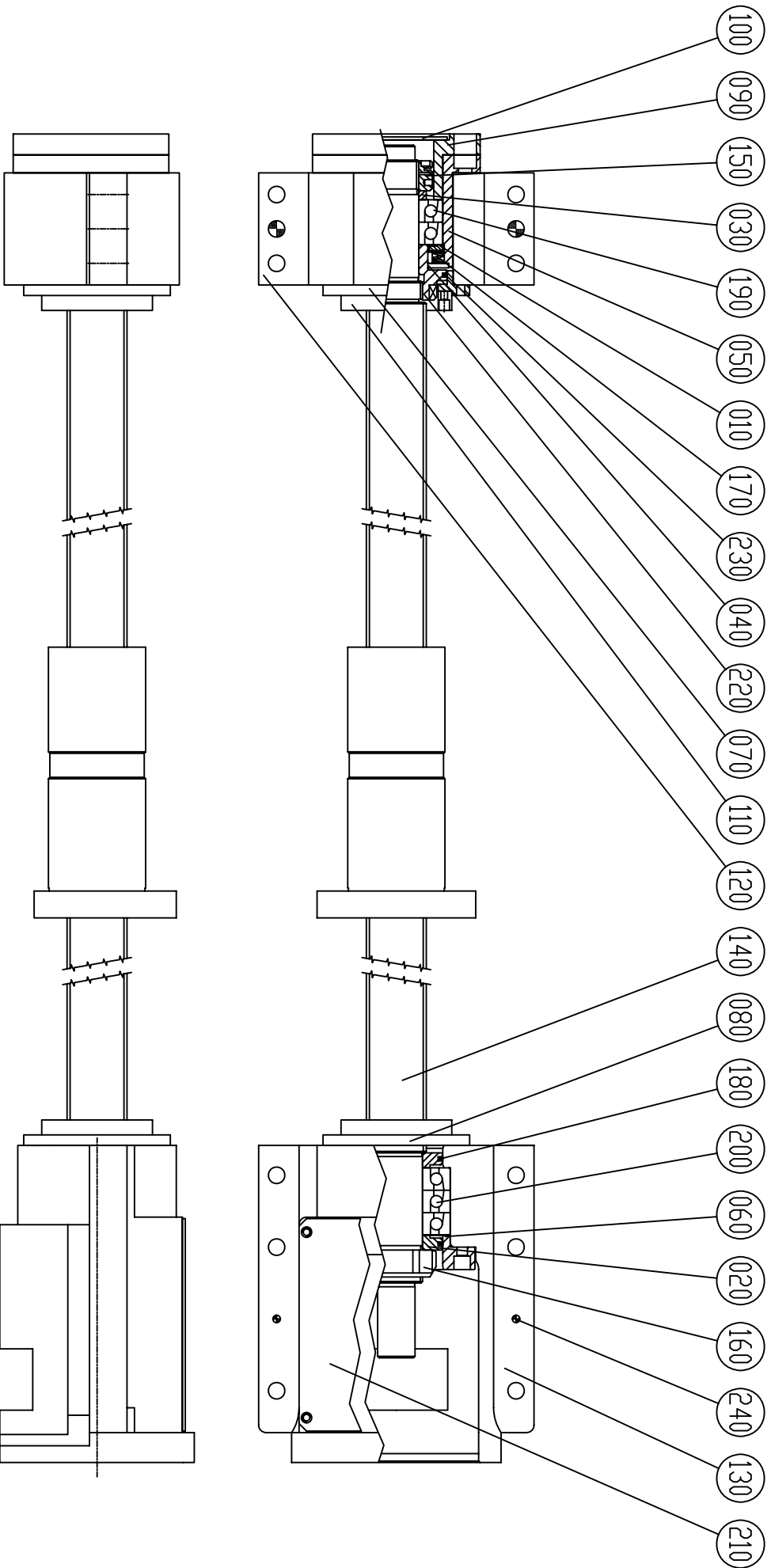

Leaderway Machinery Co. Ltd.

Scale 1:4		Drawing Name V-42iW Y軸傳動單元		Page 1/1	
Drawn 卜珮云		V-42iW Y AXIS TRANSMISSION UNIT		A4	
Control		Date 101.02.24		Draw No. 8120483A0 (2F22024)	

台灣力得衛宇龍科技股份有限公司

*單階材料用量清單

製表日期: 101-03-30

第1頁

主件品號	序號	元件品號	品名 英文品名	規 格	月量
2F23020			Z軸傳動單元 Z AXIS TRANSMISSION UNIT	V42iW	
	0010	3170053B0	軸承隔環 BEARING SPACER	3230\SCM4	1
	0020	3170054B0	前迷宮環座 LAMINAL RING BRACKET	3250\SCM4	2
	0030	3170057B0	軸承隔環 BEARING SPACER	3230\SCM4	1
	0040	3560022A0	預拉彈簧擋片 PRELOAD SPRING STOPPER	3230\S45C	1
	0050	3170070A0	Z軸尾端軸承座 REAR BEARING HOUSING	1080\S45C	1
	0060	3560016B0	軸承壓蓋 BEARING CAP	3240\SCM4	1
	0070	3560019B0	防撞膠固定座 RUBBER CUSHION BRACKET	3230\S45C	2
	0080	3560023F0	Z軸尾端軸承座壓板 PUSHING PLATE, BEARING HOUSI	3120\SCM4	1
	0090	3560132B0	尾端座蓋板 REAR BEARING HOUSING COVER	3180\SPCC	1
	0100	3560374A0	防撞膠塊 RUBBER CUSHION	4370\PU	2
	0110	3581022B0	尾端座(X軸) REAR BEARING HOUSING	1080\FC-25\3581022B2	1
	0120	3581027B0	傳動座 TRANSMISSION HOUSING	1080\FC-25\3581027B2	1
	0131	3984064A0	滾珠螺桿(Z) Z AXIS BALL SCREW	9860\市購品	1
	0140	4020401030	鎖緊螺帽 LOCK NUT	MK30	1
	0150	4020403035	鎖緊螺帽 LOCK NUT	MF35(M35xP1.5)	1
	0160	4050175012	壓縮彈簧 COMPRESSIVE SPRING	φ 1.25X φ 7.5X12L	8
	0170	4061306828	迷宮環 LAMINAL RING	FK3-AS 62/2.8/0.82	6
	0180	4402030062	螺桿軸承 BALL SCREW BEARING	BS30M62/15-P4A.DUM	1
	0190	4402435072	螺桿軸承 BALL SCREW BEARING	BS35/72/15TUM	1
	0200	3581053A0	傳動座蓋板 TRANSMISSION HOUSING COVER	7180\SPCC	1
	0210	3560021B0	軸承隔環 BEARING SPACER	3230\SCM4	1
	0220	4020402035	鎖緊螺帽 LOCK NUT	MR35(M35xP1.5)	1
	0230	4080508050	斜梢 SLIDE PIN	#8x50L(附內牙)	4

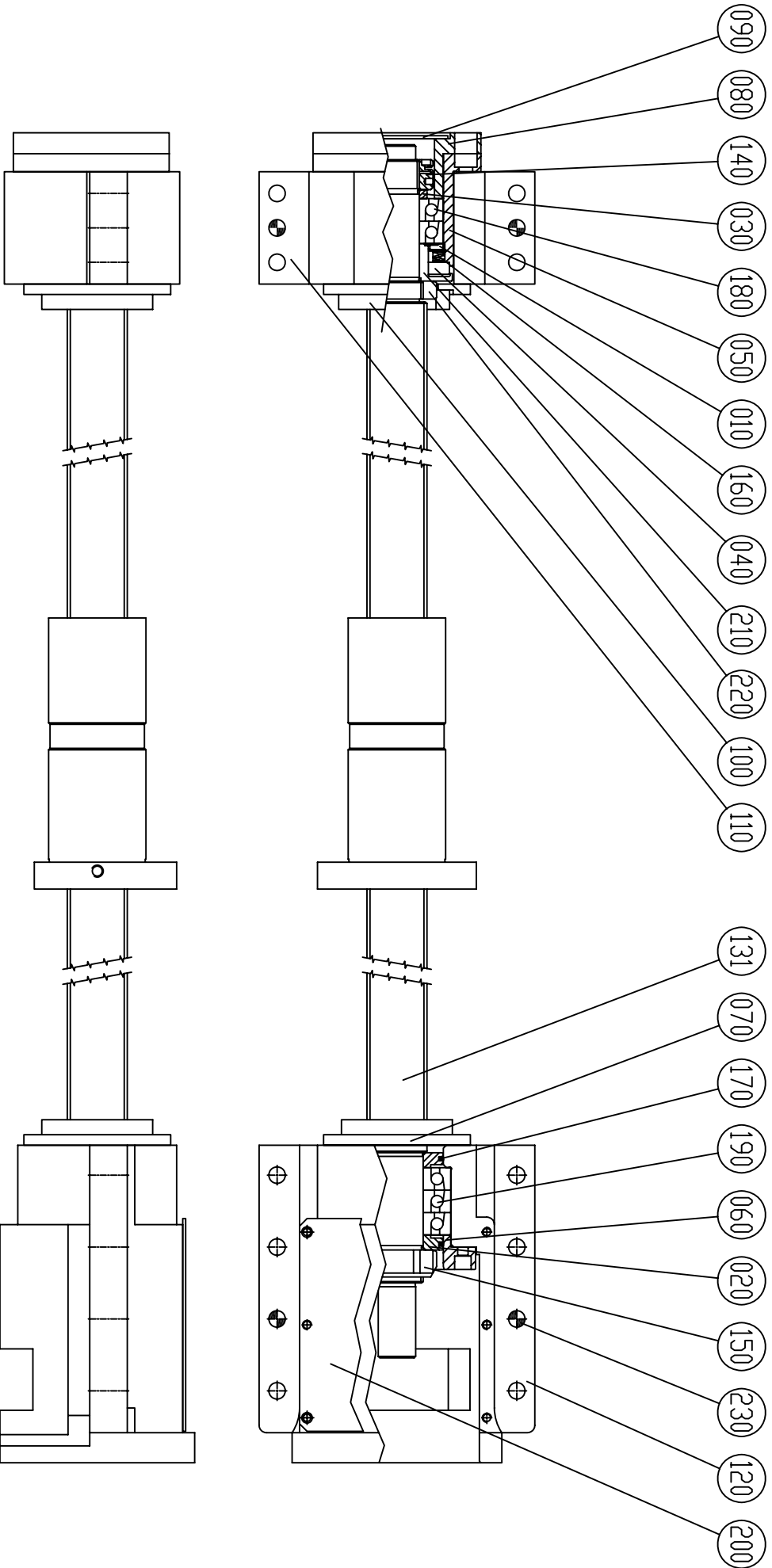

Leaderway Machinery Co. Ltd.

Scale		Drawing Name		Page	
1:4		V-42i W Z軸傳動單元		1/1	
Drawn		Name		A4	
Control		卜珮云		8120484A0 (2F23020)	
		Date		Draw No.	
		101.02.29			

台灣力得衛宇龍科技股份有限公司

*單階材料用量清單

製表日期: 101-03-30

第1頁

主作品號	序號	元作品號	品名 英文品名	規 格	月量
2F50038			外型護罩單元 LOWER ENCLOSURE GUARD UNIT	V42iW	
	0010	3582231A0	大護罩 LARGE COVER	7500\SPCC	1
	0020	3582229A0	左後護罩 (L) REAR GUARD	7500\SPCC	1
	0030	3582230A0	右後護罩 (R) REAR GUARD	7500\SPCC	1
	0040	3582232A0	左前門 (L) FRONT DOOR	7480\SPCC	1
	0050	3582233A0	右前門 (R) FRONT DOOR	7480\SPCC	1
	0060	3582234A0	前門側擋水板 FRONT DOOR PLATE	7210\SPCC	2
	0070	3581295A0	前門定位板 ORIENTATION PLATE	7210\SPCC	2
	0080	3582236A0	護罩前飾條 RUBBER RIBBON, TELESCOPIC BA	4510\SUS 303	1
	0090	3582235A0	下門軌 LOWER DOOR GUIDE	7130\SPCC	1
	0100	3580024A0	前門下門輪支架 LOWER DOOR WHEEL BRACKET	7110\SPCC	4
	0110	3520054C0	門輪 DOOR WHEEL	3260\S45C	4
	0120	3520055A0	門輪 DOOR WHEEL	3260\S45C	4
	0130	4060600028	C型扣環(孔用) C TYPE RETAINER RING	R-28	4
	0140	4060700012	C型扣環(軸用) C TYPE RETAINER RING	S-12	4
	0150	4400206001	深槽滾珠軸承 BEARING	6001ZZ 12x28x8	4
	0160	4300460100	管型把手(加高) HANDLE	U1-600L-100H	2
	0170	3560146B0	前門壓克力 ACRYLIC PLATE, FRONT DOOR	4360\ACRY	2
	0180	3560169B0	壓克力壓板 LOCKING PLATE, DOOR ACRYLIC	7120\SPCC	2
	0190	3582049A0	上門輪座 DOOR WHEEL BRACKET	7110\SPCC	2
	0200	4402000628	軸承 BEARING	628ZZ 8*24*8 日本	12
	0210	3560273D0	護罩壓克力 SIDE DOOR ACRYLIC PLATE	4360\ACRY	2
	0220	3560579A0	側門飾條 RUBBER RIBBON	4510\SUS303光面	2
	0230	3500414B0	側門把手座 SIDE DOOR HANDLE BRACKET	7180\SPCC	4
	0240	4300401421	把手(染黑) HANDLE	A-42-A	4
	0250	4090500403	鎖頭 LOCK	C-403(長型)七星小S	4
	0260	4720700081	工作燈 WORKING LIGHT	HT-S81/24V 70W	1
	0270	3580089A0	工作燈座 WORKING LIGHT BRACKET	7210\SPCC	1
	0280	3582237A0	右上蓋板 RINGHT SIDE COVER	7510\SPCC	1
	0290	3580037A0	伸臂蓋板 OUTSTRETCHED ARM COVER	7180\SPCC	1
	0300	3582238A0	左後飾板 REAR PLATE	7510\SPCC	1

<續下頁>

台灣力得衛宇龍科技股份有限公司

*單階材料用量清單

製表日期: 101-03-30

第2頁

主件品號	序號	元件品號	品名 英文品名	規 格	月量
2F50038	0310	3582239A0	左後飾板支撐座 BRACKET, REAR PLATE	7180\SPCC	1
	0320	3582240A0	右後飾板後蓋板 BRACKET, REAR PLATE	7180\SPCC	1
	0330	3582241A0	油冷機門 DOOR OF OIL COOLER	7510\2t SPCC	1
	0340	4300421602	門扣把手 DOOR LOCK	B-010長軸(六角型)+B-1602(取)	1
	0350	4300401024	門扣把手檔板 DOOR LOCK PLATE	B-01024	1
	0360	3582242A0	電器箱下飾板 REAR BRACKET POWER CABINET	7450\	1
	0370	3582243A0	右下飾板 (R) LOWER PLATE	7510\SPCC	1
	0380	3582244A0	前下飾板 LOWER PLATE	7510\SPCC	1
	0390	3560696A0	水槍座 WATER GUN SEAT	7210\SPCC	1
	0400	3560697A0	風槍座 AIR GUN SEAT	7210\SPCC	1

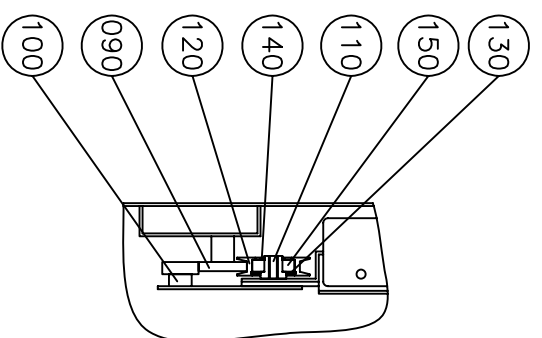

B SCALE:1:5

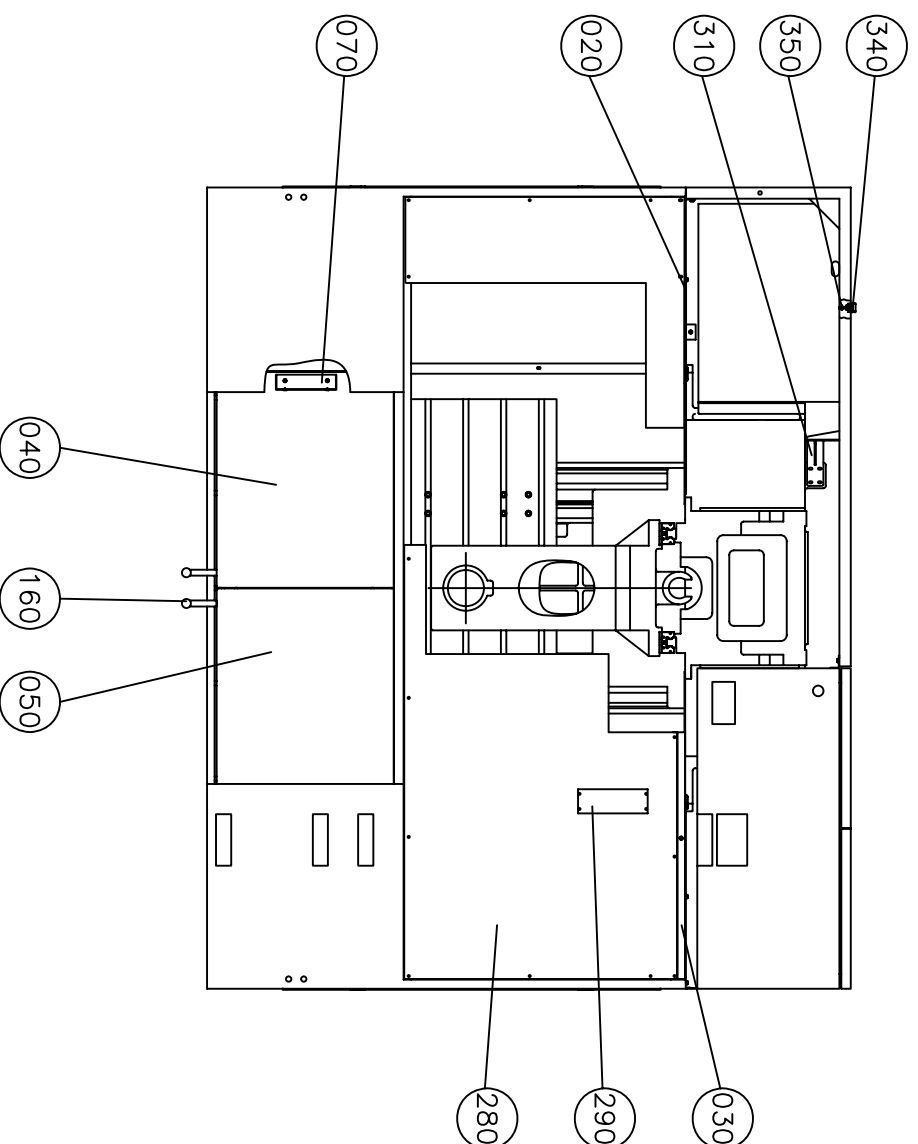

A SCALE:1:5

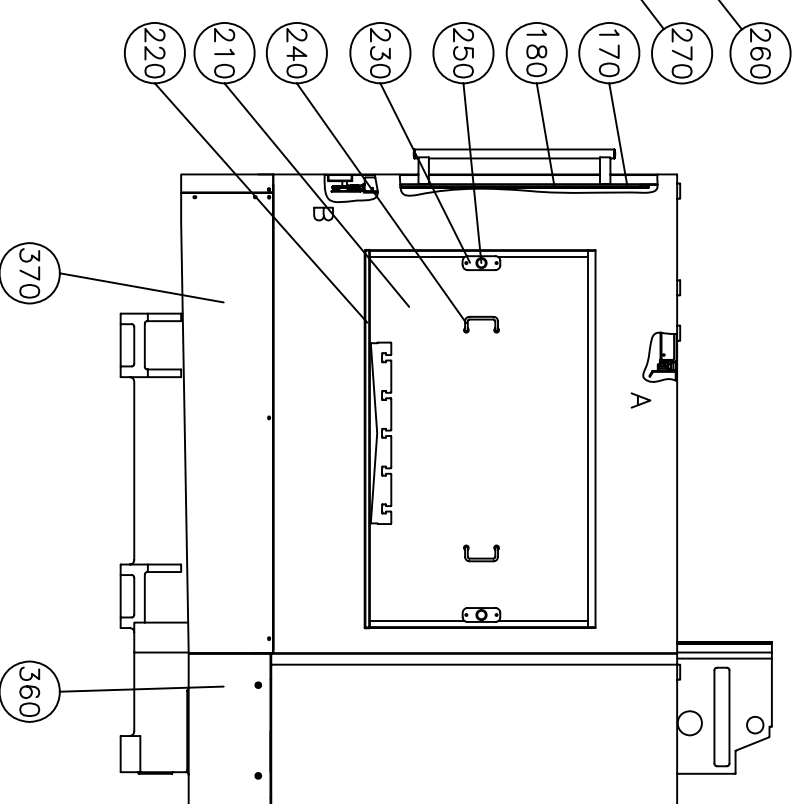
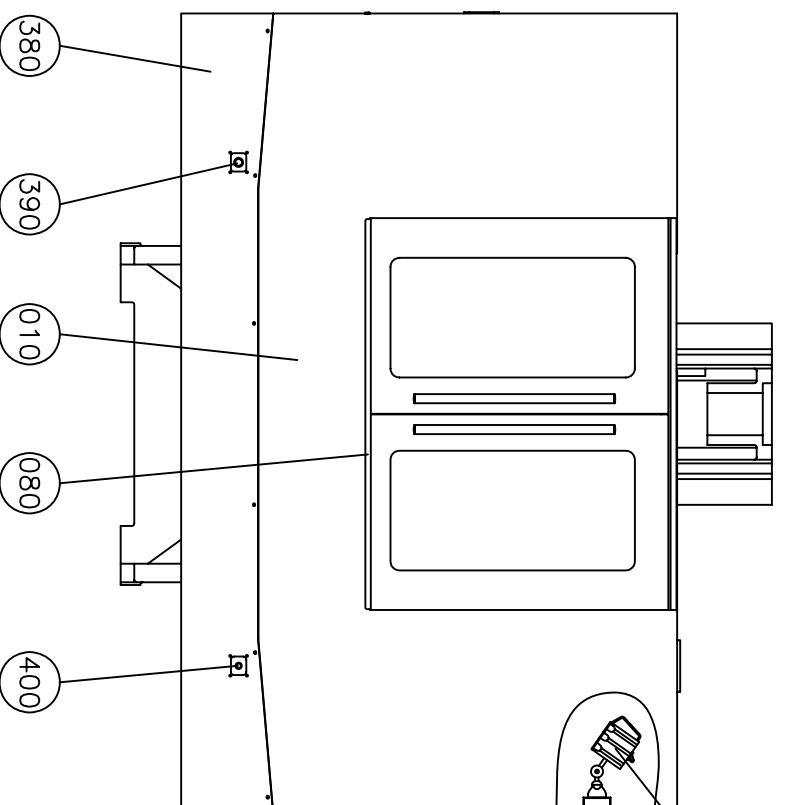
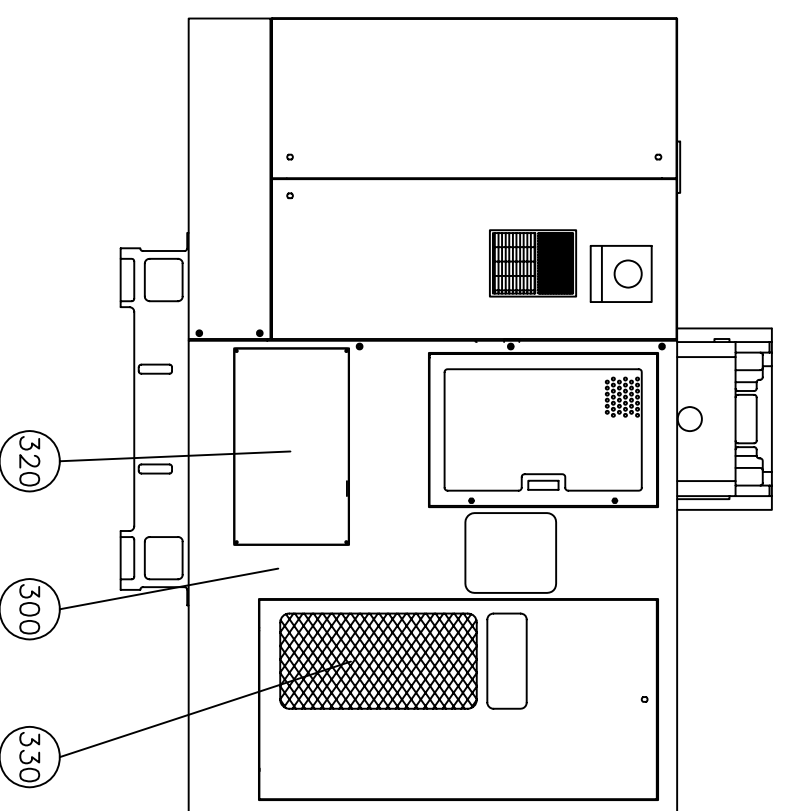
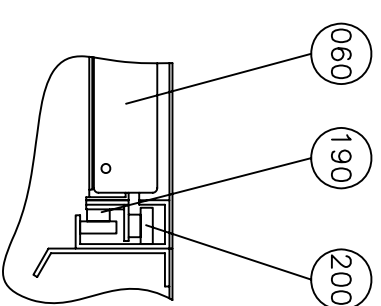

Scale		Drawing Name		Page	
1:25		V42i W 外型護罩單元		1/1	
Drawing		V42i W LOWER ENCLOSURE GUARD UNIT		A3	
Control		卜珮云		8120486A0 (2F50038)	
		101.03.02		Draw No.	
				97/12	

Leaderway Machinery Co. Ltd.

台灣力得衛宇龍科技股份有限公司

*單階材料用量清單

製表日期: 101-03-30

第1頁

主件品號	序號	元件品號	品名 英文品名	規 格	月量
2F51038			水箱單元(螺旋式排屑) COOLANT TANK UNIT(COIL TYPE)	V42iW	
	0010	3582228A0	導屑槽(螺旋式) CHIP TRAUGH	7520\SPCC	1
	0020	3582068B0	螺旋捲屑器 CHIP CONVEYOR	9570	1
	0030	4440800015	排屑器馬達 CONVEYOR MOTOR	1/4HP 1:100 FME22	1
	0040	3582069B0	排屑炮管(附蓋及防漏膠墊) CHIP THROUGH TUBE	7570\SPCC	1
	0050	3582072E0	水箱 COOLANT TANK	7580\SPCC	1
	0060	3582073E0	水箱蓋 COOLANT TANK COVER	7510\SPCC	1
	0070	3582125A0	過濾擋水板 WATER BAFFLE	7210\SPCC	1
	0080	3582102B0	蓄屑盤 CHIP PLATE	7520\SPCC	1
	0090	3582103C0	蓄屑槽 FILTER NET	7590\SPCC	1
	0100	3581304B0	水箱遮水板 DASH BOARD	7180\SPCC	1
	0110	3500428A0	管接頭座 CONNECTOR BRACKET	3150\S45C	1
	0120	4300401421	把手(染黑) HAHDLE	A-42-A	2
	0130	4430040303	切削液泵浦(直立式) COOLANT PUMP	TPHK4T3-2S	1
	0140	4510100001	油表 COOLANT LEVEL GAUGE	3''	1
	0150	4530012424	水用電磁閥KSD SOLENOID VALVE	JB4K-24V(1/2")	2

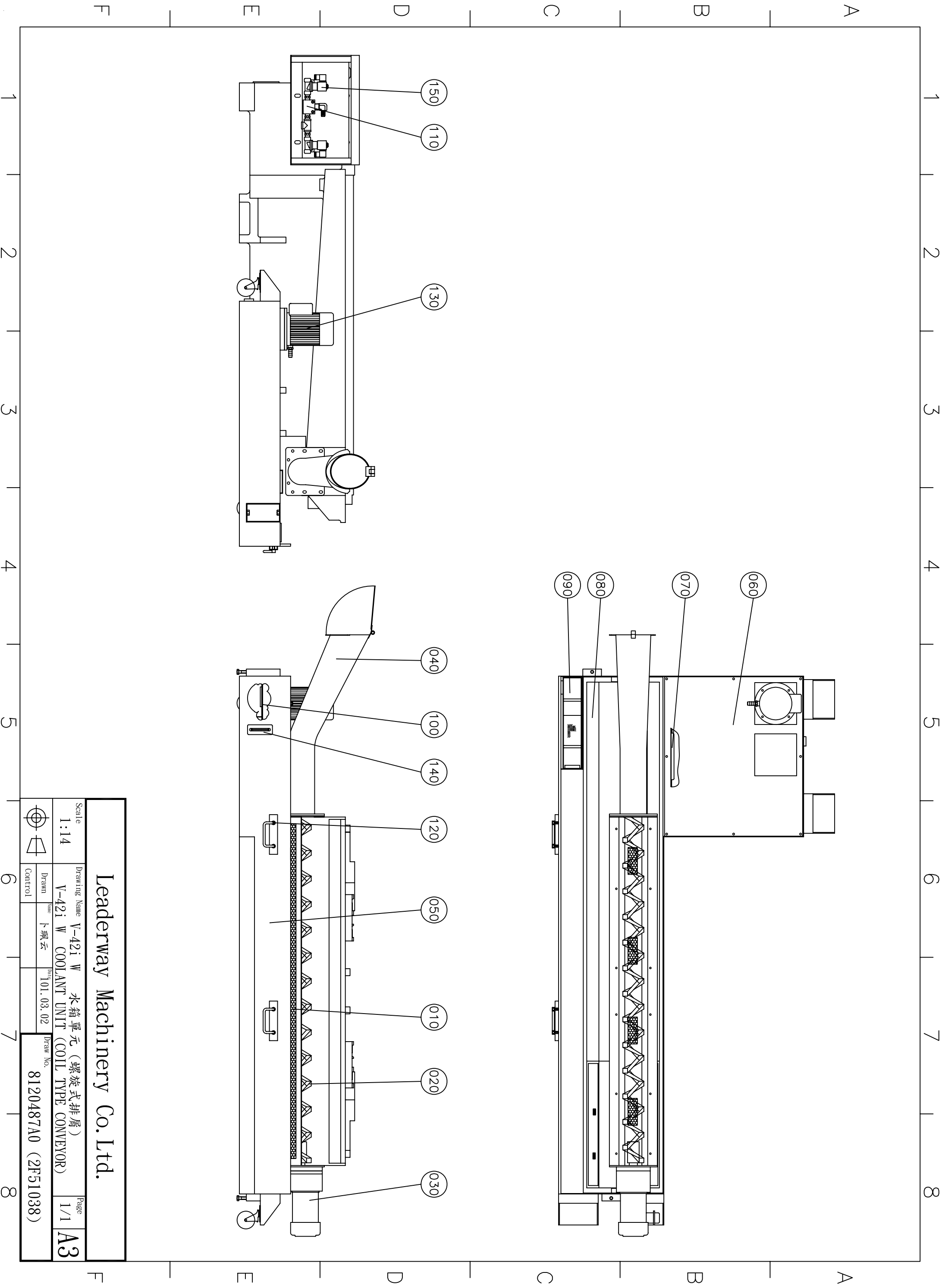

Leaderway Machinery Co. Ltd.

Scale		Drawing Name		Page	
1:14		V-42i W 水箱單元 (螺旋式排屑)		1/1	
Drawn	Control	Name	Date	Draw No.	
		V-42i W	101.03.02	8120487A0 (2F51038)	
		Drawn	Control		
		卜根云			

台灣力得衛宇龍科技股份有限公司

*單階材料用量清單

製表日期: 101-03-30

第1頁

主作品號	序號	元作品號	品名 英文品名	規 格	月量
2F52025			電氣箱單元 POWER CABINET UNIT	V42iW	
	0010	3582207A0	電氣箱 POWER CABINET	7450\SPCC	1
	0020	3582208A0	電氣箱左門 (L) DOOR, POWER CABINET	7450\SPCC	1
	0030	3582209A0	電氣箱右門 (R) DOOR, POWER CABINET	7450\SPCC	1
	0040	3582210A0	電氣箱門調整組 ADJUSTING SET FOR POWER CAB	7450\SPCC	4
	0050	3582211A0	電氣箱支架 BRACKET FOR POWER CABINET	7450\SPCC	1
	0060	3582220A0	I/O基板(上) I/O BOARD(UPPER)	7560\3t SPCCZ	1
	0070	3582221A0	I/O基板(下) I/O BOARD(LOWER)	7560\SPCCZ	1
	0080	3500149B0	主電源開關座 MAIN POWER SWITCH BRACKET	7160\SPCC	1
	0090	3500150C0	左右調整座 ADJUSTABLE BRACKET	7160\SPCC	1
	0100	3582218A0	電器箱聯動管支架 CONDUIT BRACKET	7210\SPCC	1
	0110	3582219A0	聯動管支架蓋板 COVER FOR CONDUIT BRACKET	7210\SPCC	1
	0120	3582215A0	電磁閥配置板 VALVE BRACKET	7210\SPCC	1
	0130	4090500403	鎖頭 LOCK	C-403(長型)七星小S	3
	0140	4560300010	熱交換器 HEAT EXCHANGER	HPW-10AR/EA-2A	1

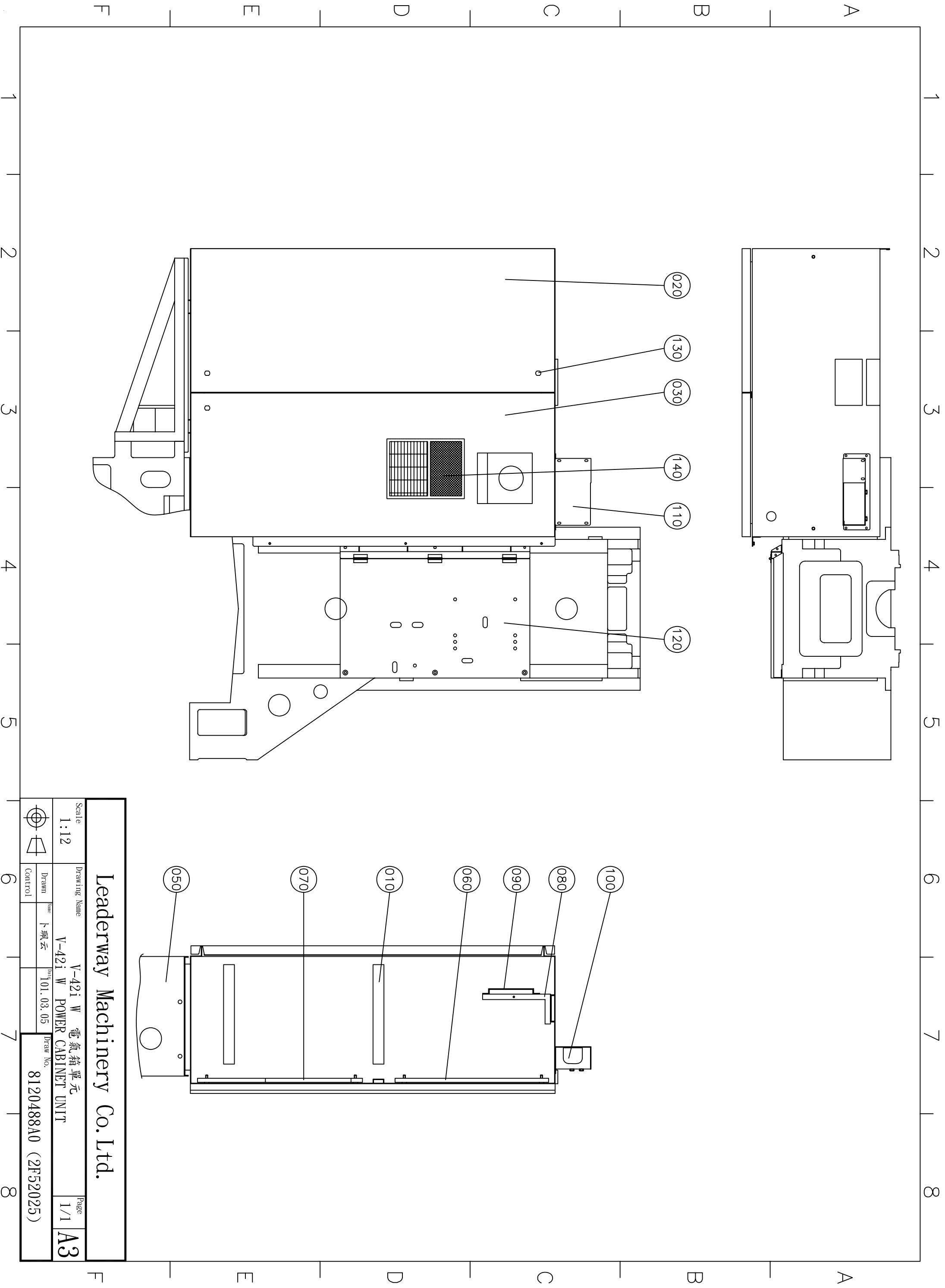

Leaderway Machinery Co. Ltd.

Scale		Drawing Name		Page	
1:12		V-42i W 電気箱單元 POWER CABINET UNIT		1/1	
Drawn	Name	Unit ^④	Draw No.	A3	
Control	卜根云	101.03.05	8120488A0 (2F52025)		

台灣力得衛宇龍科技股份有限公司

*單階材料用量清單

製表日期: 101-03-30

第1頁

主件品號	序號	元件品號	品名 英文品名	規 格	月量
2F53054			操作箱單元 三菱-70M OPERATION CABINET UNIT	V42iW	
	0010	3582222A0	伸臂 OUTSTRETCHED ARM	7470\SPCC	1
	0020	3582223A0	伸臂上蓋板(A) OUTSTRETCHED ARM COVER	7180\SPCC	1
	0030	3582224A0	伸臂上蓋板(B) OUTSTRETCHED ARM COVER	7180\SPCC	1
	0040	3582225A0	伸臂出線連結座 OUTSTRETCHED ARM CONNECTING	7210\SPCC	1
	0050	3582226A0	伸臂連結蓋板 OUTSTRETCHED ARM CONNECTING	7180\SPCC	1
	0060	3582227A0	伸臂側蓋板 OUTSTRETCHED ARM COVER	7180\SPCC	1
	0070	3500129A0	旋轉座 ROTATION BRACKET	3240\S45C	1
	0080	3580264B0	操作箱 OPERATION CABINET	7460\SPCC	1
	0090	3560523B0	操作箱後蓋 CABINET REAR COVER	7460\SPCC	1
	0100	3581309C0	洩放電阻座(大) BLEEDER RESISTANCE BRACKET	7210\SPCC	1
	0110	3581310E0	洩放電阻座蓋 COVER, BLEEDER RESISTANCE BRA	7210\SPCC	1
	0120	4300400400	管型把手(自然色) HAHDLE	U1-400L	1
	0130	4720632243	警示燈(三層) WARNING LIGHT	GSL-24V-3-B	1

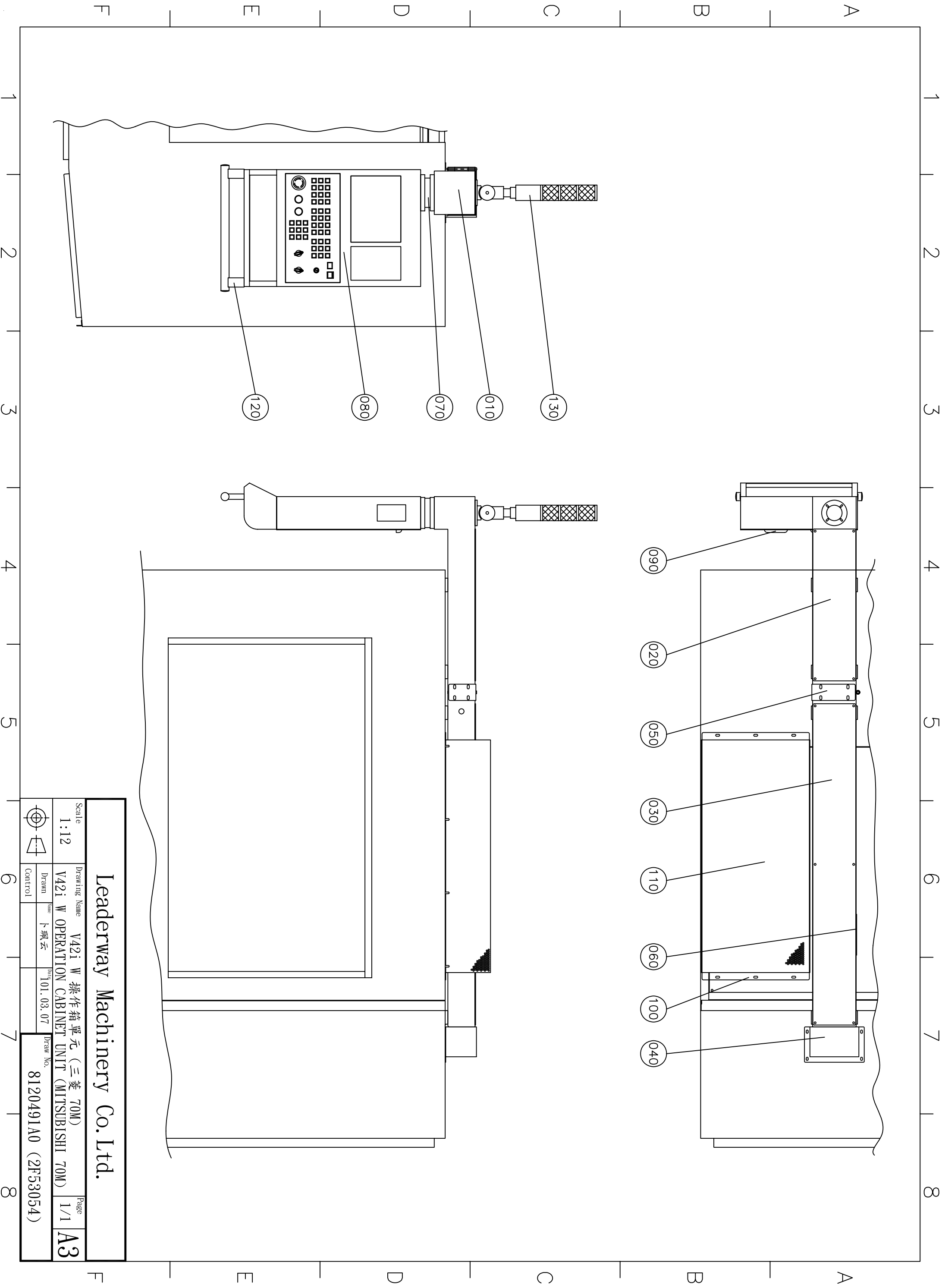

Leaderway Machinery Co. Ltd.

Scale		Drawing Name		Page	
1:12		V42i W 操作箱單元 (三菱 70M)		1/1	
Drawn		Name		Draw No.	
Control		卜根云		8120491A0 (2F53054)	
		Date			
		101.03.07			

台灣力得衛宇龍科技股份有限公司

*單階材料用量清單

製表日期: 101-03-30

第1頁

主件品號	序號	元件品號	品名 英文品名	規 格	月量
2F53055			操作箱單元 Fanuc-0iMD OPERATION CABINET UNIT	V42iW	
	0010	3582222A0	伸臂 OUTSTRETCHED ARM	7470\SPCC	1
	0020	3582223A0	伸臂上蓋板(A) OUTSTRETCHED ARM COVER	7180\SPCC	1
	0030	3582224A0	伸臂上蓋板(B) OUTSTRETCHED ARM COVER	7180\SPCC	1
	0040	3582225A0	伸臂出線連結座 OUTSTRETCHED ARM CONNECTING	7210\SPCC	1
	0050	3582226A0	伸臂連結蓋板 OUTSTRETCHED ARM CONNECTING	7180\SPCC	1
	0060	3582227A0	伸臂側蓋板 OUTSTRETCHED ARM COVER	7180\SPCC	1
	0070	3500129A0	旋轉座 ROTATION BRACKET	3240\S45C	1
	0080	3500432E0	操作箱(FANUC Oi MC) OPERATION CABINET	7460\SPCC	1
	0090	3500433C0	操作箱後蓋 CABINET REAR COVER	7460\SPCC	1
	0100	4300400400	管型把手(自然色) HAHDLE	U1-400L	1
	0110	4720632243	警示燈(三層) WARNING LIGHT	GSL-24V-3-B	1

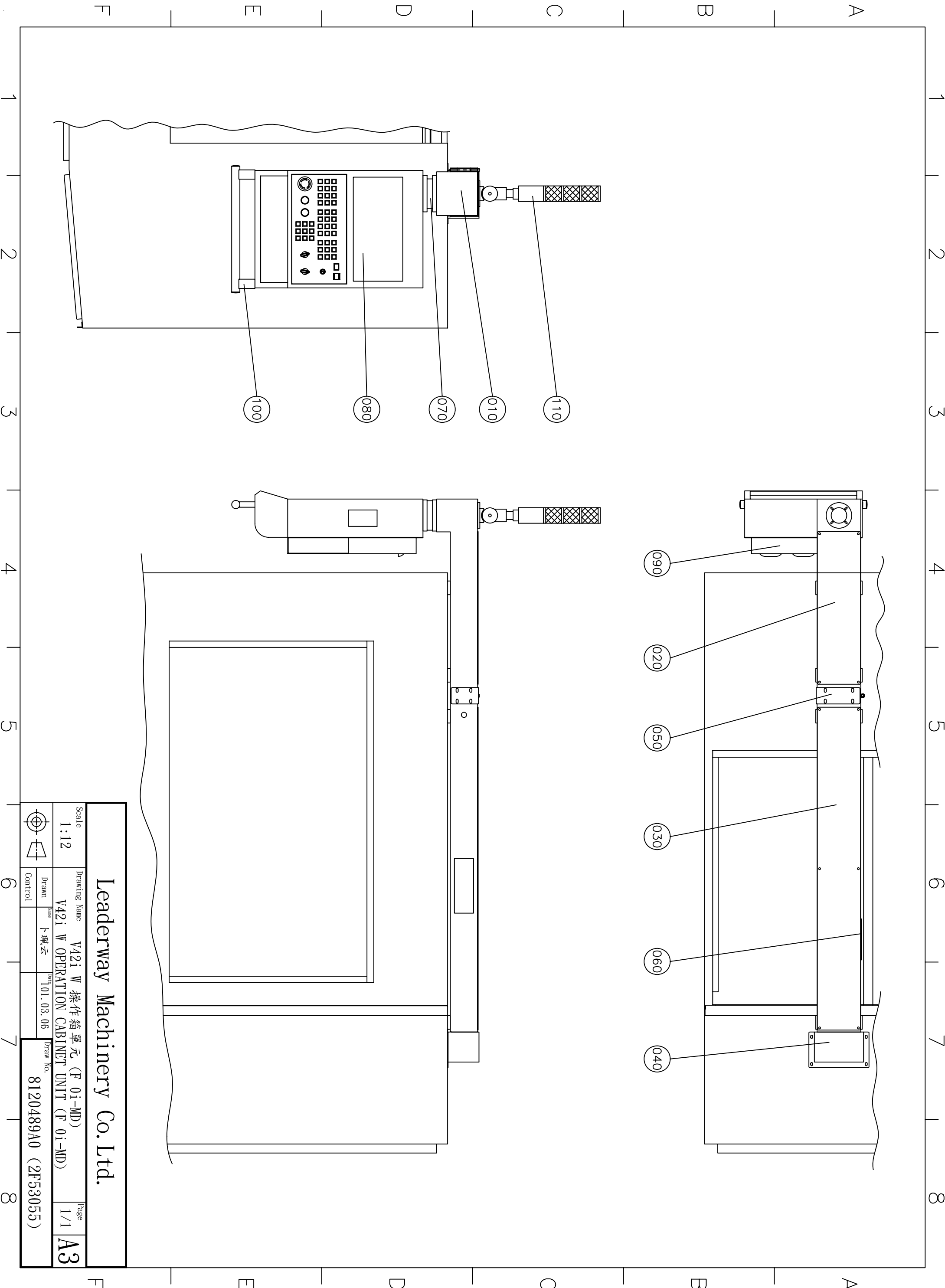

Leaderway Machinery Co. Ltd.

Scale		Drawing Name		Page	
1:12		V42i W 操作箱單元 (F 0i-MD)		1/1	
Drawn		V42i W OPERATION CABINET UNIT (F 0i-MD)		A3	
Control		卜楓云		8120489A0 (2F53055)	
		101.03.06		Draw No.	